



AGENDA
DRAINAGE DISTRICT
BOARD OF DIRECTORS
January 20, 2015
9:00 A.M.

NOTICE is hereby given in accordance with Chapter 551, Texas Government Code, that a SPECIAL MEETING of the Drainage District #1 Board of Directors will be held at the Edinburg Council Chambers, 415 W. University Drive, Edinburg, Hidalgo County, Texas. Discussion and possible action relating to the following business will be transacted:

- 1. Roll Call**
- 2. Open Forum**
- 3. Approval of Consent Agenda**
- 4. AI -48005** Approval of Purchase Agreement And Escrow Instructions with Paramount Citrus II LLC in relation to Hidalgo County Drainage District No. One Drainage Facility. (J-09 drainage project)
- 5. AI -48086** Discussion and acceptance to request Title Reports along Pharr-McAllen Drain and PSJA South Drain, to establish ownership.
- 6. AI -48098** Discussion and approval of Interlocal Cooperation Agreement among the City of Alton, Hidalgo County and Hidalgo County Drainage District No. 1 in relation to widening of drainage ditch located on 5 Mile west of Conway.
- 7. AI -48104** Discussion and authorization to enter into an Agreement between Hidalgo County Drainage District No. 1 and Hidalgo County/Urban County for assistance in the development of Penitas Drain GLO project.
- 8. AI -48102** A.) Requesting approval to accept bids received and execute Agreement with multiple vendors meeting all specified requirements for RFB No. HCDD1-14-033-12-18 "PIPES-Reinforced Concrete Pipe Tongue & Groove, Reinforced Concrete Pipe Rubber Gasket, Polyethylene & HP Storm Polypropylene Pipe".

- 1.) ACT Pipe & Supply
- 2.) CAPA - Rio Valley Pipe
- 3.) H.D. Supply Waterworks
- 4.) Aquaworks Pipe & Supply

B.) Requesting approval of Supplemental Agreement No. 6 to Work Authorization No. 9 with TEDSI Infrastructure Group in the amount of \$3,500.00 as it relates to Survey Services for Edinburg WWTP Effluent Line Discharge to HCDD No. 1 Lateral Ditch J-02 Monte Cristo Outfall.

C.) Requesting approval to advertise for RFQ No. HCDD1-15-001-02-18 "Professional Engineering Services - Pool"

D.) Requesting approval of Work Authorization No. 3 in the amount of \$15,848.25 with Dannenbaum Engineering Company-McAllen, LLC as it relates to Preliminary Plan and Profile Schematic alternatives for Hidalgo County Irrigation District No.1 Edinburg /Penitas Pump and Levee Rehabilitation.

2013 BOND SERIES

E.) Requesting approval of Change Order No. 1 in the amount of \$19,180.00 to Construction Contract No. HCDD1-14-004-02-11 with Texas Cordia Construction, LLC as it relates to "Pct. 4 - Edinburg Drain Stub-Out to the South Main Drain Control Structure Drainage Improvements".

F.) Requesting approval of Change Order No. 2 to Construction Contract No. HCDD1-13-022-04-29B with Rojas Construction & Paving to add additional working days as it relates to "Pct. 2 FM495 Drain - Wisconsin Road Crossing" no amount associated with this Change Order.

G.) Requesting approval to advertise for RFB No. HCDD1-15-002-02-25 Hidalgo County Drainage District No.1 -"Slope Repair of North Main Drain Weir No. 3 and South Main Drain Weir No. 5.

9. **AI -48136** Approval to review and update existing Drainage Committee.

10. **AI -48184** Discussion, consideration, and possible action regarding conflict of interest issues that may have occurred in awarding of contracts on HCDD#1 projects between 2007 - 2014.

11. **AI -48174** A. Discussion and approval of the job description for the position of General Manager.
 B. Discussion and approval of salary for General Manager position.
 C. Authorization to create General Manager position with appropriate slot number.
 D. Approval to authorize Financial Officer to identify and allocate appropriate funding.
 E. Approval to revise salary schedule.
12. **AI -48154** A. Written formal request by the Lee Law Firm to amend & extend the current letter of engagement [**HCDD#1-BOD-apprv. 09-30-14 with commencement date of 10-13-14 as per Lee Law Firm & approved by BOD with a term of no less than 30 and not more than 90 days**] for an additional 60 business days as detailed in the supporting documentation;
- B. Discussion and action by HCDD#1-BOD to determine and agree on what basis current letter of engagement was awarded: "calendar days" [historic & customary by HC & HCDD#1] VS The Law Firm position of "business days" including the factoring-in and calculation of "holidays" as defined by BOD and/or any combination thereof;
- C. Discussion and action if necessary by BOD as to professional liability limits provided by the Lee Law Firm as less than amount required by RFQ packet as approved by HCDD#1 with acceptance of "declaration page" as confirming document;
13. **AI -48166** Request approval to issue manual payment after review and audit procedures are complete on the following items:
- A. Application for Payment No. 1 in the amount of \$161,405.00 from Foremost Paving, Inc. related to Construction Contract no. HCDD1-14-025-09-09-Mission Inlet Arch Culvert-Aluminum Liner Plate Reline. PO#625593. Project Engineer: R. Gutierrez Engineering Corp.
- B. Application for Retainage Release in the amount of \$8,495.00 from Foremost Paving, Inc. related to Construction Contract no. HCDD1-14-025-09-09-Mission Inlet Arch Culver-Aluminum Liner Plate Reline. PO#625593. Project Engineer: R. Gutierrez Engineering Corp.
- C. Application for Payment No. 1 in the amount of \$150,255.80 from Rojas Construction & Paving related to Construction Contract No. HCDD1-13-021-04-29B. PO#625108-14. Project Engineer: R. Gutierrez Engineering Corp.

14. **AI -48159** Discussion and approval to acquire all right of way in fee simple along Pharr/McAllen South Drain and PSJA South Drain for needed maintenance operation.

15. **AI -48180** Request approval to issue manual payment once review and audit procedures are complete on the following item:
Request for Payment no. 1 in the amount of \$90,000.00 from Texas Cordia Construction related to Construction Contract No. HCDD1-14-008-07-08 Pct.2 Alamo Expressway Drain. PO#625452.

16. **Closed Session:**
Board of Directors may go into Closed Session pursuant to Chapter 551, Texas Government Code, Sections 551.071 & 551.072 to discuss the following:
 - A. **Real Estate Acquisition**

 - B. **Pending and/or Potential Litigation**

17. **Open Session:**
 - A. **Real Estate Acquisition**

 - B. **Pending and/or Potential Litigation**

18. **Closed Session:**
Board of Directors may reconvene into Closed Session for the discussion regarding the agenda items listed

19. **Open Session:**
Board of Directors may reconvene into Open Session for the discussion regarding the agenda items listed

20. **Adjourn**

AI -48005

4.

DRAINAGE DISTRICT

Meeting Date: 01/20/2015

Submitted By: Sylvia Sanchez, DRAINAGE
DISTRICT

Department: DRAINAGE DISTRICT

Information

CAPTION

Approval of Purchase Agreement And Escrow Instructions with Paramount Citrus II LLC in relation to Hidalgo County Drainage District No. One Drainage Facility. (J-09 drainage project)

BACKGROUND

Fiscal Impact

Attachments

No file(s) attached.

Form Review

Inbox	Reviewed By	Date
Budget & Management	Veronica Ortiz	01/08/2015 09:39 AM
Final Approval	Monica Badillo	01/16/2015 06:31 PM
Form Started By: Sylvia Sanchez		Started On: 01/08/2015 08:38 AM
Final Approval Date: 01/16/2015		

AI -48086

5.

DRAINAGE DISTRICT

Meeting Date: 01/20/2015

Submitted By: Sylvia Sanchez, DRAINAGE
DISTRICT

Department: DRAINAGE DISTRICT

Information

CAPTION

Discussion and acceptance to request Title Reports along Pharr-McAllen Drain and PSJA South Drain, to establish ownership.

BACKGROUND

Fiscal Impact

Attachments

No file(s) attached.

Form Review

Inbox	Reviewed By	Date
Budget & Management	Debbie Tamez	01/14/2015 03:04 PM
Final Approval	Monica Badillo	01/16/2015 06:31 PM
Form Started By: Sylvia Sanchez		Started On: 01/13/2015 02:05 PM
Final Approval Date: 01/16/2015		

AI -48098

6.

DRAINAGE DISTRICT

Meeting Date: 01/20/2015

Submitted By: Sylvia Sanchez, DRAINAGE
DISTRICT

Department: DRAINAGE DISTRICT

Information

CAPTION

Discussion and approval of Interlocal Cooperation Agreement among the City of Alton, Hidalgo County and Hidalgo County Drainage District No. 1 in relation to widening of drainage ditch located on 5 Mile west of Conway.

BACKGROUND

Fiscal Impact

Attachments

No file(s) attached.

Form Review

Inbox	Reviewed By	Date
Budget & Management	Debbie Tamez	01/14/2015 03:06 PM
Final Approval	Monica Badillo	01/16/2015 06:31 PM
Form Started By: Sylvia Sanchez		Started On: 01/14/2015 08:24 AM
Final Approval Date: 01/16/2015		

AI -48104

7.

DRAINAGE DISTRICT

Meeting Date: 01/20/2015

Submitted By: Sylvia Sanchez, DRAINAGE
DISTRICT

Department: DRAINAGE DISTRICT

Information

CAPTION

Discussion and authorization to enter into an Agreement between Hidalgo County Drainage District No. 1 and Hidalgo County/Urban County for assistance in the development of Penitas Drain GLO project.

BACKGROUND

Fiscal Impact

Attachments

No file(s) attached.

Form Review

Inbox	Reviewed By	Date
Budget & Management	Debbie Tamez	01/14/2015 03:06 PM
Final Approval	Monica Badillo	01/16/2015 06:31 PM
Form Started By: Sylvia Sanchez		Started On: 01/14/2015 11:44 AM
Final Approval Date: 01/16/2015		

AI -48102

8.

DRAINAGE DISTRICT

Meeting Date: 01/20/2015

Submitted For: Jaime Salazar

Submitted By: Jaime Salazar, DRAINAGE
DISTRICT

Department: DRAINAGE DISTRICT

Information

CAPTION

A.) Requesting approval to accept bids received and execute Agreement with multiple vendors meeting all specified requirements for RFB No. HCDD1-14-033-12-18 "PIPES-Reinforced Concrete Pipe Tongue & Groove, Reinforced Concrete Pipe Rubber Gasket, Polyethylene & HP Storm Polypropylene Pipe".

- 1.) ACT Pipe & Supply
- 2.) CAPA - Rio Valley Pipe
- 3.) H.D. Supply Waterworks
- 4.) Aquaworks Pipe & Supply

B.) Requesting approval of Supplemental Agreement No. 6 to Work Authorization No. 9 with TEDSI Infrastructure Group in the amount of \$3,500.00 as it relates to Survey Services for Edinburg WWTP Effluent Line Discharge to HCDD No. 1 Lateral Ditch J-02 Monte Cristo Outfall.

C.) Requesting approval to advertise for RFQ No. HCDD1-15-001-02-18 "Professional Engineering Services - Pool"

D.) Requesting approval of Work Authorization No. 3 in the amount of \$15,848.25 with Dannenbaum Engineering Company-McAllen, LLC as it relates to Preliminary Plan and Profile Schematic alternatives for Hidalgo County Irrigation District No.1 Edinburg /Penitas Pump and Levee Rehabilitation.

2013 BOND SERIES

E.) Requesting approval of Change Order No. 1 in the amount of \$19,180.00 to Construction Contract No. HCDD1-14-004-02-11 with Texas Cordia Construction,

LLC as it relates to "Pct. 4 - Edinburg Drain Stub-Out to the South Main Drain Control Structure Drainage Improvements".

F.) Requesting approval of Change Order No. 2 to Construction Contract No. HCDD1-13-022-04-29B with Rojas Construction & Paving to add additional working days as it relates to "Pct. 2 FM495 Drain - Wisconsin Road Crossing" no amount associated with this Change Order.

G.) Requesting approval to advertise for RFB No. HCDD1-15-002-02-25 Hidalgo County Drainage District No.1 -"Slope Repair of North Main Drain Weir No. 3 and South Main Drain Weir No. 5.

BACKGROUND

Fiscal Impact

Attachments

Pipe Bid Tab

Dannenbaum WA No. 3 Penitas

Tedsi SA No. 6 to WA No. 9

CO 2 Pct.2 Wisconsin Road

CO 1 Pct. 4 Edinburg Stub

Form Review

Inbox	Reviewed By	Date
Budget & Management	Veronica Ortiz	01/15/2015 10:28 AM
Final Approval	Monica Badillo	01/16/2015 06:31 PM
Form Started By: Jaime Salazar		Started On: 01/14/2015 09:34 AM
Final Approval Date: 01/16/2015		

Hidalgo County Drainage District No. 1

Bid No. HCDD1-14-033-12-18

BID TABULATION

Reinforced Concrete Pipe		Vendors				
		CAPA-Rio Valley Pipe	Aguaworks Pipe & Supply	HD Supply Waterworks	ACT Pipe & Supply	
15"	Class III	\$15.00/LF	NO BIDS	NO BIDS	NO BIDS	
	Class IV	\$19.30/LF				
	Class V	\$21.35/LF				
18"	Class III	\$17.65/LF				
	Class IV	\$22.35/LF				
	Class V	\$24.40/LF				
24"	Class III	\$22.95/LF				
	Class IV	\$28.45/LF				
	Class V	\$30.50/LF				
30"	Class III	\$38.10/LF				
	Class IV	\$41.00/LF				
	Class V	\$51.50/LF				
36"	Class III	\$52.20/LF				
	Class IV	\$57.70/LF				
	Class V	\$72.15/LF				
42"	Class III	\$66.95/LF				
	Class IV	\$73.15/LF				
	Class V	\$84.10/LF				
48"	Class III	\$89.50/LF				
	Class IV	\$96.10/LF				
	Class V	\$114.15/LF				
54"	Class III	\$105.10/LF				
	Class IV	\$117.05/LF				
	Class V	\$137.60/LF				
60"	Class III	\$129.80/LF				
	Class IV	\$147.15/LF				
	Class V	\$175.30/LF				
72"	Class III	\$187.50/LF				
	Class IV	\$216.20/LF				
	Class V	\$258.60/LF				

Hidalgo County Drainage District No. 1

Bid No. HCDD1-14-033-12-18

BID TABULATION

RUBBER GASKET PIPE	Vendors				
	CAPA- Rio Valley Pipe	Aguaworks & Pipe Supply	HD Supply Waterworks	ACT Pipe & Supply	
8' x 12"	\$15.00/LF	NO BID	NO BID	NO BID	
8'x 15"	\$17.65/LF				
8' x 18"	\$20.30/LF				
8' x 24"	\$26.80/LF				
8' x 30"	\$39.65/LF				
8' x 36"	\$57.45/LF				
8' x 42"	\$74.30/LF				
8' x 48"	\$90.90/LF				
8' x 54"	\$108.30/LF				
8' x 60"	\$135.80/LF				
8' x 66"	NO BID				
8' x 72"	\$187.50/LF				

Hidalgo County Drainage District No. 1

Bid No. HCDD1-14-033-12-18

BID TABULATION

Polyethylene Pipe 20ft Sections	Vendors				
	CAPA- Rio Valley Pipe	Aguaworks Pipe & Supply	HD Supply Waterworks	ACT Pipe & Supply	
8"	NO BID	\$3.29/LF	\$3.26/LF	\$3.24/LF	
12"		\$5.20/LF	\$5.15/LF	\$5.13/LF	
15"		\$7.44/LF	\$7.37/LF	\$7.33/LF	
18"		\$9.88/LF	\$9.79/LF	\$9.74/LF	
24"		\$16.12/LF	\$15.98/LF	\$15.90/LF	
30"		\$25.74/LF	\$25.52/LF	\$25.38/LF	
36"		\$29.54/LF	\$29.28/LF	\$29.13/LF	
42"		\$41.12/LF	\$40.76/LF	\$30.30/LF	
48"		\$49.32/LF	\$48.89/LF	\$48.64/LF	
54"		NO BID	NO BID	NO BID	
60"		\$87.94/LF	\$87.18/LF	\$86.73/LF	
72"		NO BID	NO BID	NO BID	

Hidalgo County Drainage District No. 1

Bid No. HCDD1-14-033-12-18

BID TABULATION

HP Storm 12"-60" Polypropylene Pipe Specification	Vendors				
	CAPA- Rio Valley Pipe	Aguaworks Pipe & Supply	HP Supply Waterworks	ACT Pipe & Supply	
12"	NO BID	\$6.65/LF	\$6.63/LF	\$6.59/LF	
15"		\$8.33/LF	\$8.28/LF	\$8.54/LF	
18"		\$10.64/LF	\$10.57/LF	\$10.51/LF	
24"		\$17.92/LF	\$17.78/LF	\$17.69/LF	
30"		\$27.85/LF	\$27.63/LF	\$27.49/LF	
36"		\$31.18/LF	\$30.93/LF	\$30.77/LF	
42"		\$43.14/LF	\$42.78/LF	\$42.56/LF	
48"		\$51.46/LF	\$51.03/LF	\$50.77/LF	
60"		\$91.50/LF	\$90.72/LF	\$90.26/LF	

Hidalgo County Drainage District No. 1

Bid No. HCDD1-14-033-12-18

BID TABULATION

HP Dual Wall Marmac Couplers	Vendors				
	CAPA- Rio Valley Pipe	Aguaworks Pipe & Supply	HP Supply Waterworks	ACT Pipe & Supply	
12"	NO BID	\$49.48/EA	\$48.22/EA	\$45.68/EA	
15"		\$56.09/EA	\$54.67/EA	\$51.79/EA	
18"		\$68.97/EA	\$67.22/EA	\$63.68/EA	
24"		\$89.26/EA	\$87.00/EA	\$82.42/EA	
30"		\$115.40/EA	\$104.37/EA	\$106.57/EA	
36"		\$135.00/EA	\$131.62/EA	\$124.69/EA	
42"		\$150.40/EA	\$146.55/EA	\$138.84/EA	
48"		\$293.90/EA	\$286.44/EA	\$271.37/EA	
60"		\$272.60/EA	\$265.71/EA	\$304.36/EA	

Hidalgo County Drainage District No. 1

Bid No. HCDD1-14-033-12-18

BID TABULATION

HP Dual Fabricated Tees	Vendors				
	CAPA- Rio Valley Pipe	Aguaworks Pipe & Supply	HP Supply Waterworks	ACT Pipe & Supply	
12"	NO BID	\$310.20/EA	\$302.33/EA	\$286.42/EA	
15"		\$397.60/EA	\$387.54/EA	\$367.15/EA	
18"		\$529.80/EA	\$516.35/EA	\$489.18/EA	
24"		\$748.10/EA	\$729.14/EA	\$690.77/EA	
30"		\$1,251.00/EA	\$1,219.40/EA	\$1,155.22/EA	
36"		\$1,648.00/EA	\$1,606.53/EA	\$1,521.98/EA	
42"		\$1,859.00/EA	\$1,811.70/EA	\$1,716.35/EA	
48"		\$2,548.00/EA	\$2,483.09/EA	\$2,352.40/EA	
60"		\$4,087.00/EA	\$3,983.50/EA	\$3,773.84/EA	

Hidalgo County Drainage District No. 1

Bid No. HCDD1-14-033-12-18

BID TABULATION

Reinforced Concrete Pipe		Vendors				
		CAPA-Rio Valley Pipe	Aguaworks Pipe & Supply	HD Supply Waterworks	ACT Pipe & Supply	
12"	11.25 Bend	NO BID	\$142.00/EA	\$139.23/EA	\$131.91/EA	
	22.5 Bend		\$151.00/EA	\$147.74/EA	\$139.97/EA	
	30* Bend		\$153.00/EA	\$149.72/EA	\$141.84/EA	
	45* Bend		\$154.00/EA	\$150.38/EA	\$142.47/EA	
	90* Bend		\$163.00/EA	\$159.72/EA	\$151.32/EA	
15"	11.25 Bend		\$184.00/EA	\$179.35/EA	\$169.92/EA	
	22.5 Bend		\$194.00/EA	\$189.46/EA	\$179.48/EA	
	30* Bend		\$233.00/EA	\$192.46/EA	\$182.33/EA	
	45* Bend		\$188.00/EA	\$183.64/EA	\$173.98/EA	
	90* Bend		\$216.00/EA	\$211.06/EA	\$199.95/EA	
18"	11.25 Bend		\$207.00/EA	\$202.09/EA	\$191.45/EA	
	22.5 Bend		\$237.00/EA	\$231.39/EA	\$219.00/EA	
	30* Bend		\$359.00/EA	\$227.57/EA	\$215.59/EA	
	45* Bend		\$241.00/EA	\$235.56/EA	\$223.16/EA	
	90* Bend		\$281.00/EA	\$274.34/EA	\$259.91/EA	
24"	11.25 Bend		\$322.00/EA	\$313.93/EA	\$297.41/EA	
	22.5 Bend		\$381.00/EA	\$371.78/EA	\$352.21/EA	
	30* Bend		\$552.00/EA	\$350.50/EA	\$332.05/EA	
	45* Bend		\$387.00/EA	\$377.91/EA	\$358.02/EA	
	90* Bend		\$430.00/EA	\$419.81/EA	\$397.72/EA	
30"	11.25 Bend		\$495.00/EA	\$483.26/EA	\$457.82/EA	
	22.5 Bend		\$521.00/EA	\$508.28/EA	\$481.53/EA	
	30* Bend		\$775.00/EA	\$538.67/EA	\$510.32/EA	
	45* Bend		\$575.00/EA	\$560.52/EA	\$531.02/EA	
	90* Bend		\$704.00/EA	\$686.17/EA	\$650.05/EA	
36"	11.25 Bend		\$607.00/EA	\$592.30/EA	\$561.13/EA	
	22.5 Bend		\$687.00/EA	\$669.82/EA	\$634.57/EA	
	30* Bend		\$934.00/EA	\$756.14/EA	\$716.35/EA	
	45* Bend		\$741.00/EA	\$722.40/EA	\$684.38/EA	
	90* Bend		\$897.00/EA	\$837.38/EA	\$828.36/EA	
42"	11.25 Bend		\$754.00/EA	\$735.47/EA	\$696.76/EA	
	22.5 Bend		\$904.00/EA	\$881.74/EA	\$835.34/EA	
	30* Bend		\$1,172.00/EA	\$911.16/EA	\$863.20/EA	
	45* Bend		\$960.00/EA	\$935.82/EA	\$886.57/EA	
	90* Bend		\$1,154.00/EA	\$1,125.09/EA	\$1,065.87/EA	
48"	11.25 Bend		\$923.00/EA	\$899.70/EA	\$852.35/EA	
	22.5 Bend		\$1,142.00/EA	\$1,113.22/EA	\$1,054.63/EA	
	30* Bend		\$1,779.00/EA	\$1,142.29/EA	\$1,082.17/EA	
	45* Bend		\$1,195.00/EA	\$1,164.52/EA	\$1,103.23/EA	
	90* Bend		\$1,257.00/EA	\$1,225.49/EA	\$1,160.99/EA	
	11.25 Bend		\$1,373.00/EA	\$1,337.92/EA	\$1,267.51/EA	
	22.5 Bend		\$1,929.00/EA	\$1,879.71/EA	\$1,780.78/EA	

Hidalgo County Drainage District No. 1

Bid No. HCDD1-14-033-12-18

BID TABULATION

Reinforced Concrete Pipe		Vendors				
		CAPA-Rio Valley Pipe	Aguaworks Pipe & Supply	HD Supply Waterworks	ACT Pipe & Supply	
60"	30* Bend		\$1,779.00/EA	\$1,733.86/EA	\$1,642.60/EA	
	45* Bend		\$2,017.00/EA	\$1,966.33/EA	\$1,862.84/EA	
	90* Bend		\$2,334.00/EA	\$2,274.62/EA	\$2,154.91/EA	

Hidalgo County Drainage District No. 1
Bid No. HCDD1-14-033-12-18
BID TABULATION

DANNENBAUM ENGINEERING COMPANY - McALLEN LLC

1109 NOLANA LOOP, SUITE 208 McALLEN, TEXAS 78504 (956) 682-3677

January 14, 2015

Hidalgo County Drainage District No. 1
902 N. Doolittle Road
Edinburg, Texas 78539

ATTN: Mr. Godfrey Garza
District Manager

REF: Hidalgo County Irrigation District No. 1 (Edinburg Pump/Penitas Pump) and Levee Rehabilitation Project

SUBJ: Proposal for Work Authorization No. 3 to Main Contract for Management and Professional Engineering Services

Dear Mr. Garza:

Attached herewith is Dannenbaum Engineering Company – McAllen, LLC's (Dannenbaum) proposal to provide Management and Professional Engineering Services for the above referenced project.

Dannenbaum proposes to perform the services as more specifically set forth in Work Authorization No. 3 "Scope of Services to be provided by the Engineer" attached herewith.

Dannenbaum proposes to provide these services for a "Lump Sum" amount of \$15,848.25 as set forth in Exhibit D – Man Hour Fee Estimate attached herewith.

Should you have any questions or require additional information, please call me at your earliest convenience at (956) 682-3677.

Sincerely,

DANNENBAUM ENGINEERING COMPANY – McALLEN, LLC

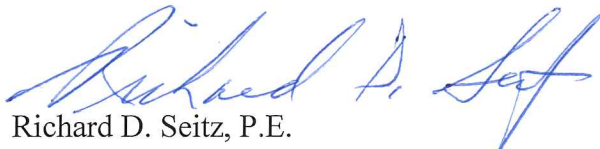

Richard D. Seitz, P.E.

Vice President Director of South Texas Operations

Attachments: Work Authorization No. 3: Exhibits A thru D

cc: DEC File No. 4817-01

EXHIBIT "A"
WORK AUTHORIZATION NO. 3
Services to be provided by the Owner

The following provides an outline of the services to be provided by the **OWNER** in the development of the "**Project**".

The **OWNER** will provide to the **ENGINEER** the following:

- (1) Authorization to the **ENGINEER** to begin work in accordance with Section 3 of this Agreement.
- (2) Payment for work performed by the **ENGINEER**, and accepted by the **OWNER** in accordance with Section 6 of the Agreement.
- (3) Assistance to the **ENGINEER**, as necessary, to obtain the required data and information from other local, regional, State and Federal agencies that the **ENGINEER** cannot easily obtain.
- (4) Provide any available relevant data the **OWNER** may have on file concerning the "**Project**".
- (5) Provide timely review and decisions in response to the **ENGINEER'S** request for information and/or required submittals and deliverables, in order for the **ENGINEER** to maintain the agreed-upon work schedule prepared in accordance with Attachment "A" of this Agreement.
- (6) Attend and participate in progress meetings as required and as coordinated and conducted by the **ENGINEER**.
- (7) Review and approve the "**Project**" design criteria.
- (8) Review and approve change orders as required and prepared by the **ENGINEER**.

EXHIBIT B
WORK AUTHORIZATION NO. 3
SCOPE OF SERVICES TO BE PROVIDED BY THE ENGINEER

The **Scope of Services** to be provided by the Engineer shall consist of the following:

- A.** The Engineer will prepare a preliminary plan and profile schematic for each of the following three (3) alternative wall sections:
1. A Secant Wall consisting of a series of adjacent concrete drill shaft columns.
 2. A Steel Sheet Pile Wall, consisting of adjacent interlocking steel panels.
 3. Construction of a new pump house and appurtenances, i.e. suction lines, pumps, etc., necessary to replace the currently existing pump house and appurtenances, i.e. suction lines, pumps, etc.
- B.** The Engineer will prepare a preliminary engineering opinions of cost for each of the following three (3) alternative wall sections:
1. A Secant Wall consisting of a series of adjacent concrete drill shaft columns.
 2. A Steel Sheet Pile Wall, consisting of adjacent interlocking steel panels.
 3. Construction of a new pump house and appurtenances, i.e. suction lines, pumps, etc., necessary to replace the currently existing pump house and appurtenances, i.e. suction lines, pumps, etc.
- C. DELIVERABLES:**
1. Submit one (1) reproducible (PDF) hardcopy and electronic copy of a Preliminary Plan and Profile Schematic for each of the three (3) alternatives.
 2. Submit one (1) copy of Engineer's Opinions of Cost for each of the three (3) alternatives.

EXHIBIT "C"
WORK AUTHORIZATION NO. 3

Work Schedule

The Engineer proposed to complete the work contained in Work Authorization No. 3 within twelve (12) Working Day following receipt of a written notice to proceed from the Hidalgo County Drainage District No. 1.

EXHIBIT "D"
MAN-HOUR & FEE ESTIMATE
WORK AUTHORIZATION NO. 3

Dannenbaum Engineering Company - McAllen, LLC
 Dannenbaum Project Number: 4817-01
 Client Name: Hidalgo County Drainage District No. 1
 Project Name: Hidalgo County Drainage District No. 1 (Edinburg Pump / Penitas Pump) and Levee Rehabilitation Project

Prepared: 1/14/2015
 Prepared by: RDS
 Reviewed by: GR
 Checked by: LHJ

DEC TASK CODE	DESCRIPTION OF WORK TASK	BASIS OF MANHOUR ESTIMATE		TOTAL MANHOURS PER TASK BY CLASSIFICATION											TOTAL MH'S PER TASK	TOTAL FEE PER TASK
				PRINCIPAL	QA OFFICER	PROJECT MGR	DOCUMENT CONTROL / SCHEDULER	CLERICAL	PROJECT ENGR (Civil)	SENIOR ENGR (Structural)	ENGR (Structural)	SENIOR DESIGN TECH	DESIGN TECH	CAD OPER		
				QNTY	UNIT	369.99	218.88	244.45	83.60	55.80	192.34	268.26	186.02	154.11		
	WORK AUTHORIZATION NO. 3															
120	Project Management and Administration	1	LS	0.00	0.00	0.50	0.50	1.00	0.00	0.00	0.00	0.00	0.00	0.00	2.00	\$ 219.83
100	Coordination meeting with HCDD#1 (To Be Held at Dannenbaum McAllen Office.)	1	LS	0.00	0.00	0.50	0.00	0.50	0.50	0.00	0.00	0.00	0.00	0.00	1.50	\$ 246.30
255	Prepare Preliminary Plan & Profile Schematic for each of three alternatives.															
	Secant Wall	1	LS	0.00	0.00	0.00	0.00	0.00	1.00	1.00	2.00	10.00	0.00	2.00	16.00	\$ 2,559.32
	Steel Retaining Wall	1	LS	0.00	0.00	0.00	0.00	0.00	1.00	1.00	2.00	10.00	0.00	2.00	16.00	\$ 2,559.32
	New Pump House	1	LS	0.00	0.00	0.00	0.00	0.00	8.00	1.00	4.00	16.00	0.00	3.00	32.00	\$ 5,295.19
355	Prepare Preliminary Engineer's Opinion of Cost for each of three alternatives.															
	Secant Wall	1	LS	0.00	0.00	0.00	0.00	0.00	0.00	0.00	1.00	3.00	0.00	0.00	4.00	\$ 648.35
	Steel Retaining Wall	1	LS	0.00	0.00	0.00	0.00	0.00	0.00	0.00	1.00	3.00	0.00	0.00	4.00	\$ 648.35
	New Pump House	1	LS	0.00	0.00	0.00	0.00	0.00	4.00	0.00	0.00	10.00	0.00	0.00	14.00	\$ 2,310.46
198	QA/QC of Preliminary Plan & Profile Schematic and Preliminary Engineer's Opinion of Cost for each of three alternatives.	1	LS	0.00	0.00	3.00	0.00	0.00	0.00	0.00	0.00	0.00	0.00	0.00	3.00	\$ 733.35
110	Prepare & Deliver presentation to County Commission, if requested.	1	LS	0.00	0.00	1.00	0.00	0.00	0.00	0.00	0.00	0.50	0.00	2.50	4.00	\$ 553.48
	SUBTOTAL			0.00	0.00	5.00	0.50	1.50	14.50	3.00	10.00	52.50	0.00	9.50	96.50	\$ 15,773.94
	TOTAL HOURS - WA #1			0.00	0.00	5.00	0.50	1.50	14.50	3.00	10.00	52.50	0.00	9.50	96.50	
	TOTAL COST - WA #1			\$0.00	\$0.00	\$1,222.25	\$41.80	\$83.70	\$2,788.93	\$804.78	\$1,860.20	\$8,090.77	\$0.00	\$881.50		\$ 15,773.93
	% OF TOTAL HOURS PER CLASSIFICATION			0.00%	0.00%	5.18%	0.52%	1.55%	15.03%	3.11%	10.36%	54.40%	0.00%	9.84%	100.00%	

EXHIBIT "E"

PROFESSIONAL ENGINEERING SERVICES CONTRACT # _____

WORK AUTHORIZATION NO. 3

THIS WORK AUTHORIZATION is made pursuant to the terms and conditions of Section I.A. of the Agreement made by and between HIDALGO COUNTY DRAINAGE DISTRICT NO. 1 hereinafter called the "Owner", and DANNENBAUM ENGINEERING COMPANY-McALLEN, LLC., Professional Engineers, hereinafter called "Engineer".

PART 1. SCOPE OF THE WORK

The purpose of this Work Authorization is for the Engineer to:

To prepare Preliminary Plan & Profile Schematics and Engineer Opinions of Cost for three (3) alternatives for the design of a protection wall and earthen levee section for the Penitas Pump House segment of the Rio Grande River levee.

The scope of services to be provided by the Owner is identified in EXHIBIT "A"- Scope of Services to be provided by the Owner attached hereto.

The scope of services to be provided by the Engineer is identified in EXHIBIT "B" – Scope of Services to be provided by the Engineer attached hereto.

PART 2. ESTIMATED COST

The estimated cost for services under this Work Authorization is \$ 15,848.25. This amount is based upon the man-hours and costs for each of the tasks outlined in the Estimated Cost Proposal attached hereto as EXHIBIT "D".

PART 3. PAYMENT

Compensation and payment to the Engineer for the services established under this Work Authorization shall be made in accordance with Articles 5, 6, and 7 of the Agreement.

PART 4. FUNDING

This Work Authorization No. 3 shall be funded through:

Funding Source: _____

Account Number: _____

Requisition Number _____

PART 5. PERIOD OF SERVICE

This Work Authorization shall become effective on the date of final acceptance of the parties hereto, and terminate upon completion of the scopes of work set forth in this Work Authorization No. 1.

PART 6. RESPONSIBILITIES AND OBLIGATIONS

This Authorization does not waive the parties' responsibilities and obligations provided under the Agreement.

PART 7. ACKNOWLEDGEMENT AND CONFIRMATION

Acknowledgement and confirmation by Dannenbaum Engineering Company-McAllen, LLC. as to content and detail of this Work Authorization No. 1.

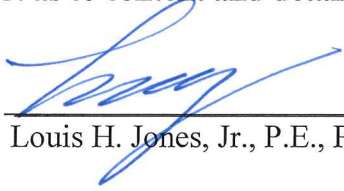
By: 
Louis H. Jones, Jr., P.E., President

PART 8. ACCEPTANCE AND APPROVAL

This Work Authorization is hereby accepted, approved by the Hidalgo County Drainage District No. 1 and Dannenbaum Engineering Company-McAllen, LLC. as indicated below and effective as of the date signed by the OWNER.

ENGINEER:
DANNENBAUM ENGINEERING COMPANY-MCALLEEN, LLC

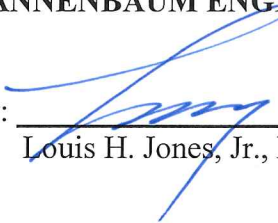
By:  _____ Date 1/14/15

OWNER:
HIDALGO COUNTY DRAINAGE DISTRICT No.1

By: _____ Date _____
Ramon Garcia, Chairman of the Board

APPROVED AS TO FORM:
ATLAS, HALL & RODRIGUEZ, LLP

By: _____ Date _____

EXHIBIT "F"

Supplemental Agreement Form

THE STATE OF TEXAS §
 §
COUNTY OF HIDALGO §

SUPPLEMENTAL AGREEMENT NO. 6 TO WORK AUTHORIZATION NO. 9

THIS SUPPLEMENTAL AGREEMENT is made pursuant to the terms and conditions of Section 4 of the Agreement made by and between the **HIDALGO COUNTY DRAINAGE DISTRICT NO. 1**, acting herein by and through its **BOARD OF DIRECTORS**, hereinafter called the OWNER and TEDSI Infrastructure Group, professional engineers of Mission, Texas, hereinafter called the ENGINEER.

WITNESSETH

WHEREAS, the OWNER and the ENGINEER executed Work Authorization No. 9 on the 31st day of October, 2006 concerning engineering and related services for the Engineering Design of HCDD #1 Lateral Drain No. J-02 (AKA Monte Cristo Outfall) facility for Phase II of Hidalgo County's Master Drain System, Hidalgo County, Texas (hereinafter referred to as the "Project"); and,

WHEREAS, Attachment B of Work Authorization No. 9, Services to be provided by the Engineer, establishes that the Engineer is to provide basic engineering and special services; and,

WHEREAS, it has become necessary to amend Attachment B of Work Authorization No. 9 to add additional Basic Services related to PS&E modifications, management and agency coordination for the Edinburg Wastewater Treatment Plant effluent line into the Monte Cristo outfall ditch system in accordance with the Interlocal Agreement between the City of Edinburg and Hidalgo County Drainage District #1 dated August 2, 2011 as defined in Item 1 of the Agreement for HCDD #1 Lateral Ditch J-02 (AKA Monte Cristo Outfall).

WHEREAS, it has also become necessary to amend Attachment B of Work Authorization No. 9 to add additional Compensation for Special Services related to survey of property lines along the limits of the project. R.O.W. for the Edinburg Wastewater Treatment Plant effluent line into the Monte Cristo outfall ditch system in accordance with Interlocal Agreement between the City of Edinburg and Hidalgo County Drainage District #1 dated August 2, 2011 as defined in Item 1 of the Agreement for HCDD #1 Lateral Ditch J-02 (AKA Monte Cristo Outfall).

AGREEMENT

NOW THEREFORE, premises considered, the OWNER and ENGINEER agree that said Agreement is amended as follows:

- I. **A)** Attachment B of Work Authorization No. 9 to add additional Basic Services related to PS&E modifications, management and agency coordination for the Edinburg Wastewater Treatment Plant effluent line into the Monte Cristo outfall ditch system in accordance with the Interlocal Agreement between the City of Edinburg and Hidalgo County Drainage District #1 dated August 2, 2011 as defined in Item 1 of the Agreement for HCDD #1 Lateral Ditch J-02 (AKA Monte Cristo Outfall).

- B)** Attachment B of Work Authorization No. 9 to add additional Compensation for Special Services related to survey of property lines along the limits of the project. R.O.W. for the Edinburg Wastewater Treatment Plant effluent line into the Monte Cristo outfall ditch system in accordance with Interlocal Agreement between the City of Edinburg and Hidalgo County Drainage District #1 dated August 2, 2011 as defined in Item 1 of the Agreement for HCDD #1 Lateral Ditch J-02 (AKA Monte Cristo Outfall).

- II. Attachment D of Work Authorization No. 9 Fee Proposal – is amended to add **\$3,500** in Special Services associated with the additional flows from the City of Edinburg Wastewater Treatment Plant effluent line into the Monte Cristo outfall ditch system in accordance with Interlocal Agreement between the City of Edinburg and Hidalgo County Drainage District #1 dated August 2, 2011 as defined in Item 1 of the Agreement for HCDD #1 Lateral Ditch J-02 (AKA Monte Cristo Outfall).

**THE ENGINEER:
TEDSI INFRASTRUCTURE GROUP**

BY: _____
Mark W. Lupher, P.E., RPLS, CFM

**THE OWNER:
HIDALGO COUNTY DRAINAGE
DISTRICT No. 1**

BY: _____
Godfrey Garza Jr.
District Manager

LIST OF ATTACHMENTS

- Attachment B – Services to be provided by Engineer
- Attachment D – Fee Proposal

**ATTACHMENT “B”
Services to be Provided by the Engineer**

INDEX

CLASSIFICATION OF SERVICES (<i>Basic or Special</i>)	1
EXPANDED DESCRIPTION OF SERVICES:	1

Engineering:

III. Basic Engineering Services and Special Engineering Services

(A) Special Services:

- (1) Boundary Survey to establish adjacent property lines *Special*

EXPANDED DESCRIPTIONS OF SERVICES. The expanded descriptions of the services to be provided by the Engineer are described on the following pages.

III. PRELIMINARY ENGINEERING, DESIGN & CONSTRUCTION

The services listed below to be provided by the **Engineer** are a summary of the services; the actual contractual services will be identified in each work authorization as outlined in Article 7 of the Work activities are as follow:

III. Basic Engineering Services and Special Engineering Services. Specific *engineering* work activities, tasks, and/or special services to be provided by the **Engineer** will include:

(A) Special Services:

- (1) Boundary Survey to establish adjacent property lines – A boundary survey shall be conducted to establish the location of property lines for properties along the projects limits.

S A #6 to Work Authorization #9
ATTACHMENT "D"
Estimated Fee Proposal
for
Edinburg WWTP Effluent Discharge
to
HCDD #1 LATERAL DITCH J-02
MONTE CRISTO OUTFALL

Special Services

Boundary Survey to establish adjacent property lines = \$3,500

Total Lump Sum Fee for Special Services = **\$3,500**

SA #6 to WA #9

CHANGE ORDER NUMBER TWO (2)

PROJECT: FM495 Drain - Wisconsin Road Crossing

DATE OF ISSUANCE: _____ EFFECTIVE DATE: _____

OWNER: Hidalgo County Drainage District No. 1

CONTRACTOR: Rojas Construction & Paving ENGINEER: R. Gutierrez Engineering Corporation
230 Frontage Rd 130 E. Park Ave.
Alamo, TX 78516 Pharr, TX 78577

You are directed to make the following changes in the Contract Documents.

Description:

1. Add 23 working days to contract

RECEIVED
 HIDALGO COUNTY
 DRAINAGE DISTRICT #1

JAN 08 2015
 3:25 AM (PM)
 BY: Rosalva

Reason:

1. Additional days needed due to delay in getting Change Order #1 approved

Attachments:

Change in Contract Price:		CHANGE IN CONTRACT TIME:	
Original Contract Price		Original Contract Time for	
\$ 201,326.50		Substantial Completion:	60
			calendar days or dates
Net Changes from previous Change Order		Net change from previous Change Orders	
\$ 40,817.22		35	
		calendar days	
Contract Price prior to this Change Order		Contract Time prior to this Change Order	
\$ 242,143.72		Substantial Completion:	95
			calendar days or dates
Net Increase (decrease) of this Change Order		Net Increase (decrease) of this Change Order	
\$ 0.00		23	
		calendar days	
Contract Price with all approved Change Orders	Net % increase (decrease) from original contract price.	Contract Time with all approved Change Orders	
\$ 242,143.72	20.30 %	Substantial Completion:	118
			calendar days or dates

RECOMMENDED:
 By: Rojas
 Engineer (Authorized Signature)
 Date: 1-7-15

APPROVED:
 By: _____
 Owner (Authorized Signature)
 Date: _____

ACCEPTED:
 By: R. Gutierrez
 Contractor (Authorized Signature)
 Date: 1/7/15

CHANGE ORDER NO. 2 TABULATION

FM495 Drain - Wisconsin Road Crossing

Item Number	Original Plan Quantity	Change Order #1 Quantities	Change Order #1 Quantities	Unit	Item Description	Unit Price	Revised Unit Price	Original Contract Cost	Change in Contract Cost of C.O.#1	Revised Contract Cost after C.O.#1	Change in Contract Cost of C.O.#2	Revised Contract Cost after C.O.#2
DRAINAGE CONSTRUCTION												
1	738.00	738.00	738.00	CY	Channel Excavation	\$ 7.00		\$ 5,166.00	\$ -	\$ 5,166.00	\$ -	\$ 5,166.00
2	3,227.00	3,227.00	3,227.00	CY	Embankment (Final) (Dens. Cont.) (Ty D)	\$ 12.00		\$ 38,724.00	\$ -	\$ 38,724.00	\$ -	\$ 38,724.00
3	1,742.00	1,742.00	1,742.00	SY	Cellulose Fiber Mulch Seeding	\$ 1.25		\$ 2,177.50	\$ -	\$ 2,177.50	\$ -	\$ 2,177.50
4	19.50	19.50	19.50	MG	Vegetative Watering	\$ 100.00		\$ 1,950.00	\$ -	\$ 1,950.00	\$ -	\$ 1,950.00
5	228.00	228.00	228.00	SY	Asphalt Conc. Pavement Overlay (1-1/2-IN)	\$ 9.00		\$ 2,052.00	\$ -	\$ 2,052.00	\$ -	\$ 2,052.00
6	65.00	83.00	83.00	SY	Cut & Restore Pavement	\$ 20.00		\$ 1,300.00	\$ 360.00	\$ 1,660.00	\$ -	\$ 1,660.00
7	284.00	326.00	326.00	CY	Cement Stabilized Backfill	\$ 40.00		\$ 11,360.00	\$ 1,680.00	\$ 13,040.00	\$ -	\$ 13,040.00
8	290.00	290.00	290.00	CY	Roadside Ditch Excavation	\$ 5.00		\$ 1,450.00	\$ -	\$ 1,450.00	\$ -	\$ 1,450.00
9	456.00	550.00	550.00	LF	Trench Excavation Protection	\$ 1.00		\$ 456.00	\$ 94.00	\$ 550.00	\$ -	\$ 550.00
10	60.00	60.00	60.00	CY	Concrete Riprap (CL B) (4-IN)	\$ 350.00		\$ 21,000.00	\$ -	\$ 21,000.00	\$ -	\$ 21,000.00
11	144.00	144.00	144.00	LF	Conc. Box Culvert (8'x8')	\$ 500.00		\$ 72,000.00	\$ -	\$ 72,000.00	\$ -	\$ 72,000.00
12	2.00	2.00	2.00	EA	Drop Inlet (Complete) (Grate Inlet) (TY C)	\$ 2,500.00		\$ 5,000.00	\$ -	\$ 5,000.00	\$ -	\$ 5,000.00
13	85.00	85.00	85.00	LF	PVC Pipe (15-IN) (Sch 40)	\$ 30.00		\$ 2,550.00	\$ -	\$ 2,550.00	\$ -	\$ 2,550.00
14	122.00	154.00	154.00	LF	PVC Pipe (18-IN) (Sch 40)	\$ 54.00		\$ 6,588.00	\$ 1,728.00	\$ 8,316.00	\$ -	\$ 8,316.00
15	417.00	417.00	417.00	LF	Remove Structure (36-IN Diversion Pipe)	\$ 5.00		\$ 2,085.00	\$ -	\$ 2,085.00	\$ -	\$ 2,085.00
16	2.00	2.00	2.00	MO	Barricades, Signs and Traffic Handling	\$ -		\$ -	\$ -	\$ -	\$ -	\$ -
17	156.00	156.00	156.00	SY	Construction Exit (Ty II) (Install)	\$ 4.00		\$ 624.00	\$ -	\$ 624.00	\$ -	\$ 624.00
18	156.00	156.00	156.00	SY	Construction Exit (Ty II) (Remove)	\$ 4.00		\$ 624.00	\$ -	\$ 624.00	\$ -	\$ 624.00
19	1,234.00	1,234.00	1,234.00	LF	Temporary Sediment Control Fence	\$ 3.00		\$ 3,702.00	\$ -	\$ 3,702.00	\$ -	\$ 3,702.00
20	417.00	417.00	417.00	LF	Thermoplastic Pipe (36-IN)	\$ 54.00		\$ 22,518.00	\$ -	\$ 22,518.00	\$ -	\$ 22,518.00
21	0.00	1.00	1.00	EA	Manhole Type M W/Grate	\$ -	\$ 9,678.64	\$ -	\$ 9,678.64	\$ 9,678.64	\$ -	\$ 9,678.64
22	0.00	51.00	51.00	SY	Plane Asph Conc Pvrmt (1.5")	\$ -	\$ 55.39	\$ -	\$ 2,824.89	\$ 2,824.89	\$ -	\$ 2,824.89
23	0.00	94.00	94.00	LF	RCP CL (III) (SPL) (42-IN)	\$ -	\$ 230.73	\$ -	\$ 21,688.62	\$ 21,688.62	\$ -	\$ 21,688.62
24	0.00	1.00	1.00	EA	Safety End (6:1) (18")	\$ -	\$ 1,453.41	\$ -	\$ 1,453.41	\$ 1,453.41	\$ -	\$ 1,453.41
25	0.00	1.00	1.00	EA	Remove Old Structure (MANHOLE)	\$ -	\$ 1,309.66	\$ -	\$ 1,309.66	\$ 1,309.66	\$ -	\$ 1,309.66
Total Drainage Construction								\$ 201,326.50	\$ 40,817.22	\$ 242,143.72	\$ -	\$ 242,143.72

TOTAL CONTRACT AMOUNTS								\$ 201,326.50	\$ 40,817.22	\$ 242,143.72	\$ -	\$ 242,143.72
-------------------------------	--	--	--	--	--	--	--	---------------	--------------	---------------	------	---------------

CHANGE ORDER NUMBER ONE (1)

Project: PCT. No. 4 Area - Edinburg Drain Stub-Out to South Main Drain Control Structure Drainage Improvements

DATE OF ISSUANCE: 1/9/2015 EFFECTIVE DATE: _____

OWNER: Hidalgo County Drainage District No. 1

OWNER'S CONTRACT NO: HCDD1-14-004-02-05

CONTRACTOR: Texas Cordia Construction, LLC ENGINEER: Guzman & Munoz Engineering and

3149-A Center Pointe Drive Surveying Inc.

Edinburg, Texas 78539 2020 E. Expressway 83

Mercedes, Texas 78570

You are directed to make the following changes in the Contract Documents.

- Description:
1. 18" pipe with 45° elbow
 2. 1 Set
 3. Back fill
 4. Remove and Relay Existing Rock Rip Rap
 5. Gate operating box to be relocated to face east
 6. 4" X 4" concrete slab be placed in front of the gate operating station to support the gas actuator and operator
 7. 2-No. 6, 4'-0" long joint tees be used to reinforce box connection for the last two joint on the east side of the box culverts on the south side joints only

- Reason for Change Order:
1. HCDD No. 1 staff has requested changes
 2. 15 rain days and 75 additional day for work requested for Change Order No. 1.
 - 3.
 - 4.
 - 5.
 - 6.

Attachments: A

CHANGE IN CONTRACT PRICE:		CHANGE IN CONTRACT TIME:	
Original Contract Price		Original Contract Time for	
\$	\$ 193,085.00	Substantial Completion:	<u>120</u> calendar days
Net Changes from previous Change Order		Net Change from previous Change Orders	
\$	\$ -		<u>0</u> calendar days
Contract Price prior to this Change Order		Contract Time prior to this Change Order	
\$	\$ 193,085.00	Substantial Completion:	<u>Dec. 1, 2014</u> calendar days or dates
Net Increase(decrease) of this Change Order		Net Increase(decrease) of this Change Order	
\$	\$ 19,180.00		<u>90</u> calendar days
Contract Price with all approved Change Orders	Net % increase(decrease) from original contract price.	Contract Time with all approved Change Orders	
\$	\$212,265.00	Mar. 1, 2015	Substantial Completion:
	9.93 %		<u>210</u> calendar days

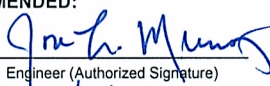
RECOMMENDED:
By: 
Engineer (Authorized Signature)
Date: 1/9/15

APPROVED:
By: _____
Owner (Authorized Signature)
Date: _____

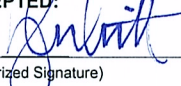
ACCEPTED:
By: 
(Authorized Signature)
Date: 1/9/2015

ATTACHMENT A

CHANGE ORDER #1

PROJECT:	Pct. No. 4 Area - Edinburg Drain Stub-Out to Main Drain Control Structure Drainage Improvements
----------	--

No.	Description	Unit Price	Qty	Unit	Amount
1.	18" PIPE WITH 45° BEND	\$3,860.00	1	LS	\$3,860.00
2.	1 SET	\$750.00	1	LS	\$750.00
3.	BACKFILL	\$3,490.00	1	LS	\$3,490.00
4.	REMOVE AND REPLAY EXIST ROCK RIP RAP	\$190.00	25	SY	\$4,750.00
5.	RELOCATE GATE OPERATING BOX TO FACE EAST 4'X4' CONCRETE SLAB TO BE PLACE IN FRONT OF	\$2,200.00	1	LS	\$2,200.00
6.	GATE OPERATING STATION TO SUPPORT THE GAS ACTUATOR AND OPERATOR 2-NO. 6, 4'-0" LONG JOINT TEES BE USED TO	\$1,220.00	1	LS	\$1,220.00
7.	REINFORCE BOX CONNECTION FOR THE LAST TWO JOINT ON THE EAST SIDE OF THE BOX CULVERTS ON THE SOUTH SIDE JOINTS ONLY	\$2,910.00	1	LS	\$2,910.00
Total Cost:					\$19,180.00

AI -48136

9.

DRAINAGE DISTRICT

Meeting Date: 01/20/2015

Submitted By: Sylvia Sanchez, DRAINAGE
DISTRICT

Department: DRAINAGE DISTRICT

Information

CAPTION

Approval to review and update existing Drainage Committee.

BACKGROUND

Fiscal Impact

Attachments

No file(s) attached.

Form Review

Inbox	Reviewed By	Date
Budget & Management	Veronica Ortiz	01/15/2015 03:34 PM
Final Approval	Monica Badillo	01/16/2015 06:31 PM
Form Started By: Sylvia Sanchez		Started On: 01/15/2015 01:59 PM
Final Approval Date: 01/16/2015		

AI -48184

10.

DRAINAGE DISTRICT

Meeting Date: 01/20/2015

Submitted By: Sandra Deleon, COUNTY
JUDGE

Department: COUNTY JUDGE

Information

CAPTION

Discussion, consideration, and possible action regarding conflict of interest issues that may have occurred in awarding of contracts on HCDD#1 projects between 2007 - 2014.

BACKGROUND

Fiscal Impact

Attachments

No file(s) attached.

Form Review

Inbox	Reviewed By	Date
Budget & Management	Veronica Ortiz	01/16/2015 04:12 PM
Final Approval	Monica Badillo	01/16/2015 06:31 PM
Form Started By: Sandra Deleon		Started On: 01/16/2015 03:52 PM
Final Approval Date: 01/16/2015		

AI -48174

11.

DRAINAGE DISTRICT

Meeting Date: 01/20/2015

Submitted By: Monica Badillo,
EXECUTIVE OFFICE

Department: EXECUTIVE OFFICE

Information

CAPTION

- A. Discussion and approval of the job description for the position of General Manager.
- B. Discussion and approval of salary for General Manager position.
- C. Authorization to create General Manager position with appropriate slot number.
- D. Approval to authorize Financial Officer to identify and allocate appropriate funding.
- E. Approval to revise salary schedule.

BACKGROUND

Fiscal Impact

Attachments

No file(s) attached.

Form Review

Inbox	Reviewed By	Date
Budget & Management	Veronica Ortiz	01/16/2015 04:14 PM
Final Approval	Monica Badillo	01/16/2015 06:31 PM
Form Started By: Monica Badillo		Started On: 01/16/2015 02:33 PM
Final Approval Date: 01/16/2015		

AI -48154

12.

DRAINAGE DISTRICT

Meeting Date: 01/20/2015

Submitted For: Marty Salazar

Submitted By: Marty Salazar,
PURCHASING DEPT.

Department: PURCHASING DEPT.

Information

CAPTION

A. Written formal request by the Lee Law Firm to amend & extend the current letter of engagement [**HCDD#1-BOD-apprv. 09-30-14 with commencement date of 10-13-14 as per Lee Law Firm & approved by BOD with a term of no less than 30 and not more than 90 days**] for an additional 60 business days as detailed in the supporting documentation;

B. Discussion and action by HCDD#1-BOD to determine and agree on what basis current letter of engagement was awarded: "calendar days" [historic & customary by HC & HCDD#1] VS The Law Firm position of "business days" including the factoring-in and calculation of "holidays" as defined by BOD and/or any combination thereof;

C. Discussion and action if necessary by BOD as to professional liability limits provided by the Lee Law Firm as less than amount required by RFQ packet as approved by HCDD#1 with acceptance of "declaration page" as confirming document;

BACKGROUND

Fiscal Impact

FISCAL YEAR: 2014

ACCOUNT #: 110-433-006-43330

FUNDS AVAILABLE? Y/N:

MATCHING FUNDS? Y/N:

BUDGETARY IMPACT:

Attachments

RFQ PACKET

AGENDA/MINUTES

CALENDER INFORMATION

CORRESPONDENCE

BACKUP

Inbox	Reviewed By	Date
Budget & Management	Veronica Ortiz	01/16/2015 10:31 AM
Purchasing Department	Marty Salazar	01/16/2015 03:33 PM
Budget & Management	Veronica Ortiz	01/16/2015 04:03 PM
Final Approval	Monica Badillo	01/16/2015 06:31 PM
Form Started By: Marty Salazar		Started On: 01/16/2015 09:50 AM
Final Approval Date: 01/16/2015		



Hidalgo County Purchasing Department
2812 S. Business Highway 281
New Administration Building
Edinburg, Texas 78539
(956) 318-2626/ Fax: (956) 318-2629

May 12, 2014

**Re: HIDALGO COUNTY DRAINAGE DISTRICT NO. 1:
RFQ NO: HCDD1-14-140-06-04-VYG-“PROFESSIONAL LEGAL SERVICES”**

RFQ NO: HCDD1-14-140-06-04-VYG

Dear Respondents:

Enclosed please find a Request for Qualifications (RFQ) packet for you review and consideration.

Hidalgo County Purchasing Department welcomes and appreciates your participation in the RFQ process.

If any further assistance is required, please do not hesitate to call the Purchasing Department at (956) 318-2626.

Sincerely,

Martha L. Salazar, CPPB
Hidalgo County Purchasing Agent

MLS/vyg

Enclosures

RFQ No. HCCD1-14-140-06-04-VYG

REQUEST FOR QUALIFICATIONS (RFQ) CHECKLIST
“PROFESSIONAL LEGAL SERVICES”

1. Request for Qualification Letter consists of 1 .
2. Request for Qualification, Legal Notice, consisting of 8 pages.
(Page 8 must be submitted with bid)
3. Exhibit “A” Requirements consisting of 6 pages.
Exhibit “A1-Integ Agreement consisting of 12 pages.
4. Exhibit “B” Selection Criteria, consisting of 4 pages.
5. Exhibit “C” Insurance Requirements consisting of 4 pages.
(Must be submitted with bid)
6. Exhibit “D” CIQ Conflict of Interest Questionnaire, consisting of 1 page.
(Copy of receipt and this form must be submitted with bid)
7. Exhibit “E” Proposer’s Affidavit consists of 1 page.
(Must be submitted with bid)
8. Bidder/Vendor Application and W-9 form consisting of 6 pages.
(Must be submitted with bid)
9. Certification Regarding Debarment consisting of 1 page.
(Must be submitted with bid)
10. Draft Letter of Engagement for Services, consisting of 0 pages.

The above mentioned items shall be found in the Request for Qualification (RFQ) packet that is attached herewith. Should you find that any of the items are not attached in its entirety please contact Purchasing by calling (956) 318-2626, advise of missing documentation, and Purchasing will forward information either through facsimile or by U.S. Mail.

Thank you,



Martha L. Salazar, CPPB, Purchasing Agent

5-12-14

Date

REQUEST FOR QUALIFICATIONS

Hidalgo County Drainage District No. 1
Edinburg, Texas

“PROFESSIONAL LEGAL SERVICES”

ACCEPTANCE DATE: JUNE 4, 2014

Contact Person:

Vangie Y. Garcia, Contract's Manager
Hidalgo County Purchasing Department
2812 S. Business Hwy. 281
Edinburg, Texas 78539
evangelina.garcia@co.hidalgo.tx.us
(956) 318-2626
Fax (956) 318-2629

LEGAL NOTICE

RFQ No: HCDD1-14-140-06-04-VYG

1. **Sealed Statements of Qualifications** will be received for "**Professional Legal Services-Hidalgo County Drainage District No. 1**", in accordance with Gov't Code 2254 (Professional Services Procurement Act) the requirements attached hereto as Exhibit "A." RFQ's should address all requirements set forth. Respondents may suggest substitutions of features which they feel would be in the best interest of Hidalgo County Drainage District No.1. Strong rationale must be presented for any deviation from the requirements. Hidalgo County Drainage District No. 1 reserves the right to reject the deviation and its effect on the overall RFQ.
2. One (1) original, five (5) copies and one (1) CD in PDF Format of all RFQs are required, with the vendor's name and address clearly typed/printed on upper left hand corner of envelope. The proper notation clearly typed/printed on the lower left hand corner of the envelope and/or package is: **REQUEST FOR QUALIFICATIONS HCDD1-14-140-06-04-VYG-"PROFESSIONAL LEGAL SERVICES"-HIDALGO COUNTY DRAINAGE DISTRICT No. 1.** Submit RFQ's to **Hidalgo County Purchasing Department, 2812 S. Business Hwy, 281, Edinburg, Texas, on or before 9:30 a.m., June 4, 2014.**

NO FACSIMILES OR LATE ARRIVALS WILL BE ACCEPTED. ANY RFQ RECEIVED AFTER THAT TIME WILL NOT BE OPENED AND WILL BE RETURNED. OVERNIGHT MAIL MUST ALSO BE PROPERLY LABELED ON THE OUTSIDE OF EXPRESS ENVELOPE OR PACKAGE.

Hidalgo County Drainage District No. 1 reserves the right to refuse and reject any/all RFQs and to waive any/all formalities or technicalities, or to accept the RFQ considered the best and most advantageous to Hidalgo County Drainage District No. 1.

3. Hidalgo County Drainage District No. 1 reserves the right to separate and accept, or eliminate any item(s) listed under this RFQ that it deems necessary to accommodate budgetary and/or operational requirements. Hidalgo County Drainage District No.1 also reserves the right to reject any or all RFQs submitted and further reserves the right to design the evaluation criteria to be used in selecting the lowest and best RFQ for approval. Receipt of any RFQ shall under no circumstances obligate Hidalgo County Drainage District No.1 to accept the lowest dollar RFQ. The award of this contract shall be made to the responsible vendor, whose RFQ is determined to be the best evaluated offer resulting from negotiation, taking into consideration the relative importance of price and other evaluation factors as herein set forth.
4. Failure of the delivered item to perform as specified or failure to meet the stated delivery schedule shall release Hidalgo County Drainage District No.1 from all obligations to the contracting party with regard to the item(s) in question. In such event, Hidalgo County Drainage District No.1 may elect to award the contract to the next-lowest responsible respondent, or to reject all RFQs and re-advertise.

5. For work to be performed at a Drainage District-owned or operated location, each vendor shall, in its sole discretion, visit the job site before preparing the RFQ and thoroughly familiarize himself/herself with existing conditions. Respondent should take field dimensions and note all circumstances which affect the RFQ.
6. No RFQ may be withdrawn within ninety (90) days from the scheduled time to accept RFQs.
7. Any interpretations, amendments, corrections or changes to this Request For Qualifications document must be in a written addendum and signed by the Chairman of the Board or his designee. Addenda will be mailed to all who are known to have received a copy of the Request for Qualifications. Respondents shall acknowledge receipt of all addenda as a part of their RFQ.
8. Hidalgo County Drainage District No.1 reserves the right to accept or reject any or all RFQs.
9. Costs are to be net F.O.B. destination, the District Prepaid.
10. Hidalgo County Drainage District No.1 is exempt from Federal Excise Tax, State Tax and Local Tax. Tax exemption certificates will be furnished upon request.
11. Funds for this procurement have been provided through the District budget for this fiscal year only. The District, on an annual basis, has the right to reconsider a contract during the budget process for ensuing years if financial resources of The District are insufficient to meet the liabilities of said contract. The award of a RFQ or contract hereunder will not be construed to create a debt for The District, which is payable out of funds beyond the current fiscal year.
12. Upon award and prior to execution of a contract, Sole Proprietorships are required to submit a copy of their social security card to the Hidalgo County Drainage District No.1 Office in order to establish an account with the District. All awarded vendors must submit a completed W-9 and a copy of their Federal ID Number Certificate.
13. DELIVERY INSTRUCTIONS (for applicable goods and/or services):
 - No deliveries accepted after 3:00 P.M., Monday-Friday.
 - At least seventy two (72) hours prior notice of delivery must be given to Martha L. Salazar, CPPB, Purchasing Agent, before delivery will be accepted.
 - If you need additional information call the office listed below:

Hidalgo County Purchasing Department
Vangie Y. Garcia, Contract's Manager
(956) 318-2626
14. BILLING AND PAYMENT INSTRUCTIONS:
 - Invoices must include:
 - a) Name and address of successful vendor
 - b) Name and address of receiving department or official

- c) Purchase Order Number (if any)
- d) Notation - "**Request for Qualifications for Professional Legal Services**"
- e) Descriptive information as to the items or services delivered, including product code, item number, quantity, etc.
- . Discount payments will be considered when offered.
- . Contact person for Billing and Payment questions:

Hidalgo County Drainage District No. 1
Accounting Dept.
902 N. Doolittle
Edinburg, TX 78542
956-292-7080

15. Schedule of Events	
RFQ Acceptance, 9:30 A.M.	<u>June 4</u>, 2014
Award of Contract	_____, 2014
Commence Work or Deliver Products	_____, 2014

16. ~~Bid or Performance Bond and Debarment Certification; Payment Under Contract:~~

~~. If the contract proposed is for the construction of public works or is for a contract for goods and services exceeding \$100,000, all bidders shall furnish a good and sufficient bid bond in the amount of five percent of the total contract price. A bid bond must be executed with a surety company authorized to do business in Texas. All participants are also required to furnish a certification or acknowledgment stating that the contractor or vendor is free from suspension or debarment pursuant to federal regulation 45CFR76.~~

~~. Together with the signing of a contract or issuance of a purchase order following the acceptance of a proposal, and prior to commencement of the actual work, the proposer shall furnish a performance bond to the HCDD1 for the full amount of the contract, if that contract exceeds \$50,000.~~

~~. If the contract is for \$50,000 or less, no money will be paid to the contractor until completion and acceptance of the work or the fulfillment of the purchase obligation to HCDD1, and, if applicable, the receipt by HCDD1 of satisfactory evidence that all subcontractors and materialmen have been paid.~~

~~. If a contract is for the construction, alteration or repair of public buildings or public works, the contractor shall provide a payment bond for a contract in excess of Twenty Five Thousand Dollars (\$25,000.00), as required by Tex. Govt. Code Ch. 2253.~~

~~. For requirements contracts, bond requirements are determined by applying the proposed unit price to the estimated quantities included in the specifications.~~

17. Ethical Standards:

. It shall be a breach of ethics to offer, give or agree to give any elected official, department head or employee, or former elected official, department head or employee, of Hidalgo County Drainage District No.1, or for any elected official, department head or employee or former elected official, department head or employee of Hidalgo County Drainage District No.1, to solicit, demand, accept or agree to accept from another person, entity or organization, a gratuity or an offer of employment in connection with any decision, approval, disapproval, recommendation, preparation or any part of a program requirement or purchase request, influencing the content of any specification or procurement standard, rendering of advice, investigation, auditing, or in any other advisory capacity in any proceeding or application, request for ruling, determination, claim or controversy, or other particular matter pertaining to any program requirement or a contract or subcontract, or to any solicitation or proposal therefore pending before any department or agency of Hidalgo County Drainage District No.1.

. It shall be a breach of ethics for any payment, gratuity or offer of employment to be made by or on behalf of a subcontractor under a contract to the prime contractor or higher tier subcontractor for any contract for Hidalgo County Drainage District No.1, or any person associated therewith, as an inducement for the award of a subcontract or order.

. No public official shall have an interest in a contract awarded hereunder except in accordance with Tex. Loc. Govt. Code Chapter 171.

. **NOTICE:** Notice: All communications by a vendor to the Hidalgo County Drainage District No.1 Board of Directors and Department Heads regarding this procurement shall be done through the Hidalgo County Purchasing Agent, CPPB, Martha L. Salazar.

No vendor, its representative, agent, or employee shall engage in private communication with a member of the Hidalgo County Board Of Directors and/or Drainage District No.1 staff regarding any procurement of goods or services by the Drainage District from the date that the RFQ is released. No private communication regarding the purchase shall be permitted until the procurement process is complete and a purchase order is granted or a contract is entered into. Members of the Board of Directors are required to make a reasonable effort to inform themselves regarding potential procurements and have a duty to inquire of vendors, their representatives or employees, the nature of any private communication being sought prior to engaging in any communication. "Private Communication" means communication with any vendor outside of a posted meeting of the governing body, a regular meeting of a standing or appointed committee, or a negotiation with a vendor which has been specifically authorized by the governing body.

18. Disclosure of Conflict of Interest

Effective January 1, 2006, Chapter 176 of the Texas Local Government Code requires that any vendor, person, consultant or contractor considering doing business with The Hidalgo County Drainage District No.1 ("Drainage District") to disclose in the Conflict of Interest Questionnaire (the "CIQ") attached as Exhibit D, the vendor, person, consultant or contractor's affiliation or business relationship that might cause a conflict of interest with Hidalgo County Drainage District No.1. By law, the CIQ must be filed with

the Hidalgo County Drainage District No.1 Office no later than the seventh business day after the date the person becomes aware of facts that require that statement to be filed. The disclosure requirement applies to a person or business that contracts or seeks to contract with The Hidalgo County Drainage District No.1 for the sale or purchase of property, goods or service. Any purchase order or contract resulting from this process shall be considered null and void if the successful bidder fails to comply with Texas Local Government Code Chapter 176. Vendors, consultants, contractors and others who desire to conduct business with The Hidalgo County Drainage District No.1 are encouraged to refer to Texas Local Government Code Chapter 176 for the details of this law. An offense under Texas Local Government Code Chapter 176 is a Class C Misdemeanor.

Please Submit completed forms to the Hidalgo County Purchasing Department located at 2812 S. Business Hwy. 281 , Edinburg, Texas 78539-Hidalgo County.

COMPLETION AND SUBMISSION OF FORM CIQ IS THE SOLE RESPONSIBILITY OF THE PROSPECTIVE VENDOR.

19. If, during the life of any contract or engagement, the successful vendors' net prices generally available to other customers for items awarded herein are reduced below the contracted price, it is understood and agreed that the benefits of such reduction shall be extended to Hidalgo County Drainage District No.1.
20. Qualifications, and all goods and services provided thereunder, shall comply with all federal, state and local laws concerning this type(s) of goods and/or services.
21. Minimum Standards for Responsible Prospective Vendors: A prospective vendor must affirmatively demonstrate vendors' responsibility. A prospective vendor, by submitting a proposal, represents to Hidalgo County Drainage District No.1 that it meets the following requirements:
 - . Possess or is able to obtain adequate financial resources as required to perform under the proposal;
 - . Be able to comply with the required or proposed delivery schedule;
 - . Have a satisfactory record of performance;
 - . Have a satisfactory record of integrity and ethics;
 - . Be otherwise qualified and eligible to receive an award.
22. Successful respondent will pay or cause to be paid, without cost or expenses to Hidalgo County Drainage District No.1, all FICA, FUTA/SUTA and Federal Income Withholding Taxes of all employees, and all wages and benefits as required by Federal or State law. Successful vendors officers, agents and/or employees will not be entitled to any benefits of an employee or elected official of Hidalgo County Drainage District No.1, including, but not limited to, benefits associated with Hidalgo County Drainage District No.1 civil service system.

23. Any contract award to a successful vendor will be in effect until (a) the contract expires, (b) delivery and acceptance of products, and/or performance of services ordered, or (c) terminated by Hidalgo County Drainage District No.1 with thirty (30) day's written notice prior to cancellation.
24. Hidalgo County Drainage District No.1 reserves the right to enforce performance of any contract awarded hereunder in any manner prescribed by law or deemed to be in the best interest of Hidalgo County Drainage District No.1 in the event of breach or default by successful vendor; Hidalgo County Drainage District No.1 reserves the right to terminate any contract immediately in the event a successful vendor fails to:
 - A. Meet schedules;
 - B. Pay any required fees or taxes; or
 - C. Otherwise perform in accordance with the requirements.
25. Successful respondent shall defend, indemnify and save harmless Hidalgo County Drainage District No.1 and all its elected officials, officers, agents and employees from all suits, actions, or other claims of any character, name and description brought for or on account of any injuries or damages received or sustained by any person, persons, or property on account of any negligent act or fault of the successful respondent, or of any agent, employee, subcontractor or supplier in the execution of, or performance under, any contract which may result from proposal award. Successful vendor indemnifies and will indemnify and save harmless Hidalgo County Drainage District No.1 from liability, claim or demand on their part, agents, servants, customers, and/or employees whether such liability, claim or demand arise from event or casualty happening or within the occupied premises themselves or happening upon or in any of the halls, elevators, entrances, stairways or approaches of or to the facilities within which the occupied premises are located. Successful respondent shall pay any judgment with costs which may be obtained against Hidalgo County Drainage District No.1 growing out of such injury or damages, and shall, upon request, provide a defense to Hidalgo County Drainage District No.1 by counsel reasonably acceptable to Hidalgo County Drainage District No.1. Successful respondents indemnity hereunder shall include, but is not limited to, claims relating to patent, copyright or trademark infringement, and the like, arising out of the goods or services provided by successful vendor.
26. Successful respondent shall warrant that all items/services shall conform with the specifications and/or all warranties provided under the Uniform Commercial Code and be free from all defects in material, workmanship and the like. Items supplied under a contract pursuant to this Request for Statement of Qualifications shall be subject to Hidalgo County Drainage District No.1 approval. Items found to be defective or not meeting specifications shall be replaced by successful vendor within two business days at no expense to Hidalgo County Drainage District No.1. Items not picked up within one (1) week after notification shall be deemed a donation to Hidalgo County Drainage District No.1 and may be used or disposed of at Hidalgo County Drainage District No.1 discretion and without waiver of any other rights of Hidalgo County Drainage District No.1 as to the item's nonconformity.
27. This document and any disputes arising hereunder shall be governed and construed according to the laws of the State of Texas, and will be performable exclusively in Hidalgo County, Texas.

28. The successful respondent shall not assign, sell, transfer or convey its rights under any awarded contract, in whole or in part, without the prior written consent of Hidalgo County Drainage District No.1.
29. Respondents shall provide with the RFQ response, a list of at least **three (3) references** where like services have been supplied by their firm. Include the name of the business or government, address, telephone number and name of representative or contact person.
30. Respondents must provide **all** documentation requested with this RFQ in their response. Failure to provide this information may result in rejection of the RFQ as non-conforming

Request for Qualifications
For
Hidalgo County Drainage District No.1

“Professional Legal Services”
RFQ No: HCDD1-14-140-06-04-VYG

To: Vangie Y. Garcia, Contract’s Manager
Hidalgo County Purchasing Department
2812 S. Business Hwy. 281
Edinburg, Texas 78539

In accordance with the Requirements, and subject to all laws and regulations of the United States and state and local laws, the undersigned bidder proposes and commits to furnish all labor, equipment, material, software and services as set forth in the documents hereinbefore mentioned. The undersigned bidder further agrees, upon acceptance of its RFQ, to execute a Letter of Engagement and/or Purchase Order issued by Hidalgo County Drainage District No.1 for performing and completing the scope of services as described in the RFQ within the time stated and for the fees negotiated once finalized in the documents attached hereto and made a part hereof.

Participant(s) acknowledges receipt of all of the pages of the documents referenced in the Request for Qualifications Checklist presented in connection with this procurement. Bidder understands that Hidalgo County Drainage District No. 1 reserves the right to reject any or all RFQs and further reserves the right to design the evaluation criteria to be used in selecting the lowest and best qualified.

Participant(s) agrees that this RFQ shall be good and may not be withdrawn for a period of ninety (90) calendar days after the scheduled closing time for accepting RFQs, as contained in the Requirements.

Respectfully submitted,

Bidder: _____

Address: _____

By: _____

Printed Name/Title: _____

EXHIBIT A

REQUIREMENTS

**HIDALGO COUNTY DRAINAGE DISTRICT NO. 1
REQUEST FOR QUALIFICATIONS**

“PROFESSIONAL LEGAL SERVICES”

RFQ No: HCDD1-14-140-06-04-VYG

Hidalgo County Purchasing Department will be accepting Statement of Qualifications for Hidalgo County Drainage District No. 1 from a qualified licensed attorney/firm for the provision of "Legal Services for the review of agreement between Hidalgo County Drainage District No.1 and Integ Corporation". The Hidalgo County Purchasing Department will receive sealed envelopes containing Statements of Qualifications for the provision as specified herein.

Statements of Qualifications will be accepted until **9:30 A.M., Wednesday, June 6, 2014.** **ANY RFQ RECEIVED AFTER THAT TIME WILL NOT BE OPENED AND WILL BE RETURNED.**

Deliver Submittal to:

RFQ Number: HCDD1-14-140-06-04-VYG
Vangie Y. Garcia, Contract's Manager
Hidalgo County Purchasing Department
2812 S. Business Hwy. 281
Edinburg, Texas 78539

The Submittal Envelope Must Show The RFQ Number, Name And Acceptance Date.

The following outlines the Request for Qualifications:

SECTION I - GENERAL TERMS AND CONDITIONS

ADDITIONAL INFORMATION: Hidalgo County Drainage District No.1 is requesting that statements of qualifications be routed to Vangie Y. Garcia, Contract's Manager, at 2812 S. Business Hwy. 281, Edinburg, Texas 78539. **WRITTEN QUESTIONS WILL BE ACCEPTED VIA EMAIL OR FACSIMILE BY NO LATER THAN Wednesday, May 21, 2014 at 5:00 P.M. at evangelina.garcia@co.hidalgo.tx.us or by fax at (956) 318-2629.** Responses will be sent to all applicants via email or facsimile by Friday, May 23, 2014. **TELEPHONE INQUIRIES WILL NOT BE ACCEPTED.**

PROPOSER'S AFFIDAVIT: Respondents to this RFQ must submit a signed Proposer's Affidavit (attached herein in Exhibit "E") certifying that the submission is (1) not the result of Collusion as described in the Proposer's Affidavit; (2) that the Respondent does not have a Conflict of Interest as described in the Proposer's Affidavit; or that the Respondent has not and will not attempt to lobby directly or indirectly as described in the Proposer's Affidavit.

NON-DISCRIMINATION: Respondents, during the performance of this contract, will not discriminate against any employee or applicant for employment because of race, religion, sex, national origin or disability except where religion, sex, national origin or disability is a bona fide occupational qualification reasonably necessary to the normal operation of the contractor.

PROCESSING TIME FOR PAYMENT: Submitters are advised that a minimum of thirty (30) days is required to process invoices for payment.

ELECTRONIC TRANSMISSION OF RFQs: Hidalgo County's Drainage District No. 1 will not accept telegraphic or electronically transmitted submissions.

PROOF OF FINANCIAL AND BUSINESS CAPABILITY: Respondents must, upon request, furnish satisfactory evidence of their ability to furnish products or services in accordance with the terms and conditions of these requirements. Hidalgo County Drainage District No. 1 will make the final determination as to the submitter's ability.

RESPONDENT DEFAULT: Hidalgo County Drainage District No. 1 reserves the right, in case of submitter default, to procure the articles or services from other sources and hold the defaulting submitter responsible for any excess costs occasioned thereby.

RESTRICTIVE OR AMBIGUOUS REQUIREMENTS: It is the responsibility of the respondent to review the Request for Statement of Qualifications (RFQ) packet and to notify the Drainage District in writing if the requirements are formulated in a manner that would unnecessarily restrict competition. These criteria also apply to requirements that are ambiguous.

RFQ DELIVERY: Hidalgo County Drainage District No. 1 requires submitters, when hand delivering statements of qualifications, to have a Drainage District representative time/date stamp and initial the envelope.

SIGNING OF QUALIFICATIONS: In order to be considered, all submittals **must** be signed. Please sign the original in **blue** ink.

WAIVING OF INFORMALITIES: Hidalgo County Drainage District No.1 reserves the right to waive minor informalities or technicalities when it is in the best interest of District.

SUBCONTRACTING: The successful submitter may not subcontract the award without the written consent of the Board of Directors of The Hidalgo County Drainage District No.1.

TERM : The term of engagement for a thirty (30) day period with Hidalgo County Drainage District's sole option to extend (if necessary) under same engagement fees, terms and conditions.

DAVIS BACON ACT: All selected and awarded firms are required to include the Davis-Bacon Act when advertising and developing specifications (**if applicable**).

SECTION II -RFQ REQUIREMENTS

REQUEST FOR QUALIFICATIONS: The required contents and limitations for the preparation of the SOQ are described in this section. Failure to provide the requested information or adhere to any Drainage District limitations will result in disqualification of the submitted SOQ.

CONTENTS: The required contents for the SOQ are presented below in the order they should be incorporated into the submitted document.

UNDERSTANDING OF THE PROJECT: This section should demonstrate the attorney/firm's understanding of the scope of engagement services and requirements meeting all federal, state, local statutes and rules that apply. This description should be concise, candid, and limited to no more 2 pages in length.

FIRM QUALIFICATIONS:

Hidalgo County Drainage District No. 1 is seeking to contract with a competent, qualified legal attorney/firm to engage legal services as detailed under “Scope Of Services”, but not limited to, the following:

- Attorney/firm licensed to practice law in the State of Texas;
- Attorney/firm with a minimum of 20 years of experience with extensive knowledge in contract law/litigation.

Additionally, this section should include a description of the attorney/firm's project personnel and their most recent similar project(s). For each project, a client contract name and phone number should be included for reference purposes. Additionally, the names of the personnel proposed for this project who participated in the listed projects should be provided. This project list is limited to 5 pages.

PERSONNEL AND STAFFING: The firm should provide an organizational chart for the project and summary paragraph of the project work to be performed by each proposed staff member. Biographic summaries that highlight the experience relevant to the specific project responsibilities should be provided for all proposed personnel. There is a one (1) page limitation for each biographic summary provided.

REQUIRED CERTIFICATIONS AND SUBMITTAL:

This section will contain any licenses and certifications as required by the State of Texas, Hidalgo County. Any/All qualified attorney/firm is required to furnish a certification or acknowledgment stating that the attorney/firm is/are free from suspension or debarment pursuant to federal regulations 45CRF76. Certification form is included in this packet and must be completed and submitted as part of the response on the SOQ. The attorney/firm should add copies of its/their Professional Liability Insurance as well as all other applicable insurances as required by Hidalgo County Drainage District No. 1 and as detailed in Exhibit “C” contained herein.

SCOPE OF SERVICES:

The scope of services required by Hidalgo County Drainage District including but not limited to, as follows:

- Review of the agreement between Hidalgo County Drainage District No. 1 and Integ Corporation;
- Conduct an investigation into the issues of payment of \$3,735,000.00 to Integ for construction management of Hidalgo County Drainage District No. 1 Master Drainage Plan Phase II Projects;
- Research, review, prepare and provide a report to the Hidalgo County Drainage District No. 1 Board of Directors within 30 days after engagement and receipt of purchase order.

NUMBER OF COPIES TO BE SUBMITTED: Hidalgo County Drainage District No.1 requires **one (1) original, five (5) copies and one (1) CD in PDF Format.**

SECTION III : SELECTION AND SCHEDULES

SELECTION PROCEDURES/EVALUATION CRITERIA:

The evaluation consists of a 100-point scoring system based on the Evaluation Criteria - Exhibit B. However, at the sole discretion of Hidalgo County Drainage District No. 1 Board of Directors.

(A) The Hidalgo County Drainage District No. 1 Board of Directors and/or an Evaluation Committee (selected and/or designated by the Board of Directors) will review, score and evaluate the SOQs received in response to this Hidalgo County Drainage District No.1 request for qualifications.

(B) After the SOQs have been reviewed, scored and evaluated, the committee will present a grid to the Hidalgo County Drainage District No. 1 Board of Directors meeting for the purposes of ranking in order to proceed with the next step of the process; negotiating a contract/letter of engagement.

Qualifications will be graded on a point system with emphasis on ability to service the Drainage District and experience, including but not limited to the following:

A. Attorney/Firm Qualifications:

1. The attorney/firm should provide the resume of each of the firms' professionals (if applicable) who will be assisting on this project (only if more than one attorney will be providing services). (All attorneys should be licensed to practice in the State of Texas).
2. Contract and litigation law specializations or board certifications should also be detailed in each résumé. (Copies of current valid licenses, certifications and registrations should be included in this section and other pertinent information that demonstrates their qualifications to perform the services required.)

B. Experience of Attorney/Firm/Team:

1. The attorney/firm shall demonstrate with detail the *minimum* 20 years experience in the area of contract and litigation law. Please site at least 5 cases that relate very similar circumstances as to the scope of services and requirements of this project.
2. The attorney/firm shall demonstrate in detailed writing (*if exceeding* the 20 years experience) in the area of contract and litigation law. Please site at least 5 cases that relate very similar circumstances as to the scope of services and requirements of this project.

The attorney/firm shall designate experienced staff to completely and efficiently perform the services. The designated individuals may not be replaced during the project unless approved by the Drainage District No. 1 Board of Directors. The attorney/firm must state the approach and/or (methodology) in achieving and rendering all services detailed.

C. **Understanding the Scope of Engagement of Services/Requirements:**

The attorney/firm should provide as much background information as to its' experience in providing similar services in connection to contract and litigation law. This should be concise, candid, and limited to no more than 2 pages in length.

D. **Commitment to term of Engagement of Attorney/Firm:**

The attorney/firm shall commitment to the term of engagement for thirty (30) day period with Drainage District's sole option to extend, if necessary, with same fees, terms and conditions.

NEGOTIATION PROCESS: PARTICIPATING FIRMS ARE NOT TO PROVIDE A FEE PROPOSAL WITH THIS SUBMITTAL: The fee will be negotiated in accordance with the Professional Services Procurement Act, Tex. Govt. Code Ann. 2254.

Negotiations will commence with Drainage District Board of Directors approved attorney/firm.

- 1.) Attorney/Firms will be asked to submit as part of those negotiations a "scope of service" including fees.
- 2.) The negotiated letter of engagement/contract including best and final offer with the successful attorney/firm will be presented to the Board of Directors (including compliance with all requirements set for in RFQ) for consideration and final approval.
- 3.) If negotiations are not successful, the Hidalgo County Drainage District No.1 will recommend to the Board of Directors that negotiations be ceased and commence to negotiate with the next qualified attorney/firm.

**RFQ NO: HCDD1-14-140-06-04-VYG
HIDALGO COUNTY DRAINAGE DISTRICT NO. 1
"REQUEST FOR QUALIFICATIONS-PROFESSIONAL LEGAL SERVICES"**

EXHIBIT "A1"-INTEG AGREEMENT

STATE OF TEXAS §
 §
COUNTY OF HIDALGO §

**AMENDMENT TO MANAGEMENT CONSULTING AGREEMENT
BETWEEN HIDALGO COUNTY DRAINAGE DISTRICT NO. ONE
AND INTEG, CORP.**

This Amendment to the contract between Integ, Corp. and Hidalgo County Drainage District No. One (the "District") effective the 2nd day of February, 2010 is made between Integ, Corp. and the District (the "Amendment") as follows:

WHEREAS, Integ and District entered into a Contract on February 6, 2007 (the "Agreement") in which Integ agreed to provide management consulting services;

WHEREAS, Article 10 of the Contract provides the term of the Agreement expires on February 16, 2010 and the District and Integ desire to amend the Agreement to provide for the term of the Agreement to expire on February 16, 2013;

NOW THEREFORE, for and in consideration of the tasks performed by Integ and other valuable consideration the receipt and sufficiency of which are hereby acknowledged, and this mutually agreed Amendment to the Agreement, Integ and District hereby agree to the following Amendment to the Agreement:

1. Article 10.1 Term of the Agreement is deleted in its entirety and the following is inserted in lieu thereof:

The term of the Agreement shall be six (6) years commencing February 16, 2007 and ending February 16, 2013, unless earlier terminated as provided herein. District at its sole option may extend this Agreement for one additional year on the same terms and conditions as provided for herein.

2. Except as modified herein, all terms and conditions of the Agreement, as amended, remain in full force and effect. Integ and District ratify and confirm the terms and provisions of the Agreement as amended.

EXECUTED IN DUPLICATE ORIGINALS and effective as of the day and year first written above.

Hidalgo County Drainage District No. One

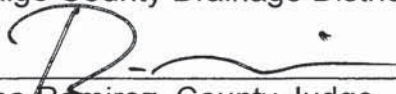

Rene Ramirez, County Judge

Integ, Corp.



Godfrey Garza, President

APPROVED AS TO FORM:

ATLAS & HALL, LLP

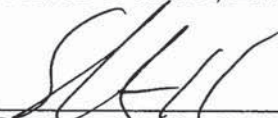

By: Stephen L. Crain

MANAGEMENT CONSULTING AGREEMENT

THIS Agreement is made and entered into effective as of the 6TH day of February, 2007 by and between HIDALGO COUNTY DRAINAGE DISTRICT NO. ONE, a political subdivision of the State of Texas with its offices at 902 N. Doolittle Road, Edinburg, Hidalgo County, Texas 78539 ("District"), and INTEG, CORP., a Texas corporation with its principal offices in Hidalgo County, Texas ("Integ").

WITNESSETH:

WHEREAS, District, through its employees and agents, engages in the operation of drainage, storm water collection, and related functions, as authorized under Chapter 49 and 56, Texas Water Code.

WHEREAS, pursuant to Tex. Water Code Section 49.056, The Board of directors of District is authorized to employ or contract with a party to perform the services of General Manager of the District;

WHEREAS, District recognizes the benefits of contracting with a party who will employ the former manager of District, which manager has the training, experience, and qualifications necessary to manage and supervise the functions of the District.

WHEREAS, District has determined that the proper, orderly and efficient delivery of quality services to District's constituents can be accomplished by contracting with Integ on a contract basis as Godfrey Garza, through Integ, desires to provide services to other individuals or entities;

WHEREAS, Integ is willing to accept the responsibility of providing management and oversight of the District's functions in accordance with Chapters 49 and 56, Texas Water Code, recognized standards, the policies of the District, and the terms and conditions set forth in this Agreement; and

WHEREAS, the parties desire to provide a full statement of their agreement in connection with the provision of services by Integ to District during the term of this Agreement;

NOW, THEREFORE, in consideration of the mutual promises of the parties hereto, and of the mutual covenants and conditions hereinafter expressed, the parties hereto covenant each with the other, as follows:

1. OBLIGATIONS OF INTEG

Integ agrees to provide the following services to District during the term of this Agreement in accordance with the terms and provisions hereof:

- 1.1 **Management.** Subject to the direction of the Board of Directors of

the District, Integ shall perform the duties of the manager of the District, including, but not limited to the following:

- A. (1) perform the overall management and compliance of the programs as specified by local, state and federal regulations and coordinating the programs with the needs of the private/public sector;
- (2) plan, coordinate and submit recommendations to the Board of Directors of the District, upon request, long and short range studies, policies and procedures and recommendations which will promote effective management of the District;
- (3) oversee the implementation and completion of all program activities and services;
- (4) establish and maintain necessary standards of performance to assure activities and projects of District comply with plans, applicable laws and regulations;
- (5) provide accurate and timely reports (fiscal and programmatic) as specified by applicable laws, regulations, and requirements of the Board of Directors;
- (6) coordinate the responsibilities and assignments of the District's staff for effective management;
- (7) keep the Board of Directors informed of applicable laws, rules, and regulations that affect the District;
- (8) foster an attitude of unity and harmony within the District and between the District and other governmental bodies and agencies within the County of Hidalgo and State of Texas;
- (9) recommend policies on organization, finance, programs, personnel and all other function of the District;
- (10) exercise discretion and judgment in matters not covered by this Agreement and/or policies of the District;
- (11) support and interpret District policies for the benefit of the staff and community and administer the District accordingly;
- (12) act as the custodian of records of the District;
- (13) communicate with the District's attorney on matters in litigation or potential litigation except as otherwise directed by the Board of Directors; and

- (14) perform such other reasonable duties related to the position of manager as assigned by the Board of Directors of District;
- (15) perform such reasonable duties related to the administration of project specifics such as the Raymondville Drain and Roadway systems as they pertain to the District boundaries.
- (16) provide Floodplain Management and coordinate with FEMA, IBWC and ACOE on drainage issues as they relate to the Hidalgo County Drainage District #1 and Hidalgo County.
- (17) provide management service for the implementation of the Hidalgo County Master Drainage System Phase II Bond Issue as it relates to construction development, phasing and implementation.
- (18) develop a public information service on a monthly basis to report to the Board of Directors and residents of the District on the status of on-going projects as they relate to the Hidalgo County Drainage District #1 Phase II Master Plan Improvements.

B. The duties of Integ may change to a reasonable degree from time to time by the Board of Directors without terminating this Agreement, so long as such duties are of an administrative nature. During the Term, Integ shall perform the services herein contemplated faithfully, diligently and to the best of Integ's ability, consistent with all applicable laws, and all applicable local, state and federal regulations.

C. Integ is expected to devote such time to the performance of the services hereunder as is reasonable required to fulfill its obligations to District hereunder. Integ will be permitted to perform consulting and other services for other firms, individuals or local governments when such other work does not impair the fulfillment of Inter's obligations under this Agreement.

1.2 **Records.** Integ shall assist District in keeping or causing to be kept accurate and complete records of all matters pertaining to the operations of the District.

1.3 **Consultation with District Employees.** Integ shall consult with the employees of District regarding work hours required to accomplish the work of District.

Integ shall assist District in training of employees.

1.4 **Consultation.** Integ shall make its representatives available at reasonable times for consultations with District's Board of Directors and administrative employees.

2. INSURANCE COVERAGE

At all times during the term of this Agreement, District will carry general liability insurance and errors and omissions insurance covering Integ and its officers, agents and employees, in the amount of the maximum liability limits of the District under the Texas Tort Claims Act at District's expense. District will provide a certificate of insurance to Integ evidencing such coverage and will notify Integ immediately if any change in coverage occurs for any reason.

It is further agreed that in the event of cancellation or termination of the Agreement, if District's coverage is on a claims-made basis, District shall purchase the Optional Extension Period Coverage available to District under District's insurance policies. Evidence of such coverage shall be immediately furnished to Integ on request by Integ.

3. PARTIES' RELATIONSHIP

Integ, at all times will act as an independent contractor managing and supervising District's operations, and will not act or hold itself out to third parties as an employee or agent of District.

4. TAXES AND BENEFITS

Unless District determines, in its reasonable discretion that Integ is required by the Internal Revenue Code of 1986, as amended, and regulations adopted thereunder to treat Integ or its officers, agents or employees as an employee, District will not withhold income tax or Social Security tax on behalf of Integ or its officers, agents or employees. In addition, without regard to District's determination under the preceding sentence, neither Integ nor its officers, agents or employees, will have any claim under this Agreement or otherwise against District for vacation pay, sick leave, unemployment insurance, worker's compensation, retirement benefits, disability benefits, or employee benefits of any kind. Integ will have exclusive responsibility for the payment of all such

taxes and arrangement for insurance coverage and will discharge such responsibility fully.

5. INCURRING FINANCIAL OBLIGATION

Integ will incur no financial obligation on behalf of District without prior written approval of District's Board of Directors, and any financial obligation incurred on behalf of the District without its prior written consent shall be the obligation of Integ. Except as herein provided with respect to vehicle allowances, travel reimbursement and cellular phone allowances, Integ will be responsible for all of its personal and professional expenses, including but not limited to, membership fees and dues and expenses of attending conventions and meetings.

6. OFFICE SPACE

During the term of this Agreement, District will make available office space in District's office for Integ for use by Integ to provide the services pursuant to this Agreement.

7. REMUNERATION

7.1 **Compensation for Services of Integ.** Integ shall be entitled to compensation for the services provided by it hereunder in the amounts set out in Exhibit "A" which is attached hereto and incorporated herein by reference. Integ accepts such amounts as Integ's compensation for services to District and other items or services performed pursuant to this Agreement.

7.2 **Payment to Integ.** Integ will be paid by District on the first business day of each calendar month based on the schedule of fees set forth in Exhibit "A."

7.3 **Reimbursement of Out-of-Area Travel.** In addition to any vehicle allowance provided to Integ herein, Integ shall be entitled to reimbursement of its out-of-pocket expenses for travel, meals and lodging for any travel outside the boundaries of Hidalgo, Cameron, Willacy and Starr Counties which is required of Integ in the performance of its services hereunder. Such reimbursement shall be at the same rates provided to elected officials and employees of Hidalgo County for out-of-town travel.

8. NON-DISCRIMINATION

Integ will not discriminate on the basis of race, color, sex, age, religion, national origin or handicap in provided services under this Agreement.

9. CONFLICT OF INTEREST

Prior to entering into any contract or business relationship or receiving any payment from any individual or entity who is financially interested in a contract or project with the District or who is a director or employee of any such individual or entity, Integ shall disclose the proposed contract, business relationship or payment to the Board of Directors of District. Integ's disclosure shall be entered into the minutes of a meeting of District. Integ agrees to abide by the majority vote of the Board of Directors as to whether the Board of Directors determines a conflict of interest may exist because of the proposed relationship. Should the Board of Directors of District determine a conflict of interest may exist, Integ agrees not to provide services to or receive payment from such individual or entity. The Board of Directors of District may, upon a majority vote, terminate this Agreement upon three (3) days notice to Integ upon finding that Integ has violated the terms of this paragraph.

10. TERMINATION OF AGREEMENT

10.1 **Term.** The term of the Agreement shall be three (3) years commencing February 16, 2007 and ending February 16, 2010, unless earlier terminated as provided herein. District at its sole option may extend this Agreement for one additional year on the same terms and conditions as provided for herein.

10.2 **No Termination without Cause.** Neither District nor Integ shall have the right to terminate this Agreement without cause.

10.3 **Termination with Cause.**

A. Termination by District. District may terminate this Agreement immediately upon the occurrence of any of the following events:

(i) Any conduct of Integ or any officer, agent or employee of Integ which jeopardizes the health, safety, or welfare of any person, or the safety, reputation, or the regular functions of the District.

(ii) The conviction of Integ or any officer or principal shareholder of Integ of any crime punishable as a felony or involving moral turpitude or immoral conduct.

(iii) The death of Godfrey Garza or the occurrence of illness or injury thereto reasonably likely in the sole opinion of the Board of Directors to lead to the inability of Integ to perform services under this Agreement for a period in excess of thirty (30) days.

(iv) Finding by the Board of Directors of District that Integ violated the provisions of numbered paragraph 9 hereof.

(v) In addition, if Integ commits a material breach of any of the terms of this Agreement, other than those listed in subsections (i) through (iv) above, then District may terminate this Agreement upon Integ's failure to remedy such breach upon no less than thirty (30) days written notice.

B. Termination by Integ. In the event District breaches any material term of this Agreement, then Integ may terminate this Agreement upon District's failure to remedy such breach upon no less than thirty (30) days written notice.

11. NOTICES

Any notices or payments permitted or required by this Agreement shall be deemed made on the day personally delivered in writing or mailed by certified mail, postage prepaid, to the other party at the address set forth below or to such other persons and address as either party may designate in writing:

If to Integ: Integ, Inc.
 Attention: Godfrey Garza, President
 R.R. 13, Box 715
 Edinburg, Texas 78539

If to District: Hidalgo County Drainage District No. One
 Attention: District Chairman
 100 E. Cano, 2nd Floor
 Edinburg, Texas 78539

12. LAW

The interpretation and enforcement of this Agreement shall be governed by the laws of the State of Texas.

13. NO IMPLIED WAIVER

Any waiver of enforcement of any provision or waiver of any breach of this Agreement, whether or not recurring, shall not be construed as a waiver of any subsequent enforcement or breach.

14. SEVERABILITY

The invalidity or unenforceability of any provision of this Agreement will not affect the validity or enforceability of any other provision.

15. ASSIGNABILITY

The rights and obligations of the parties hereto shall inure to the benefit of and be binding upon their successors and assigns. Except as expressly provided herein to the contrary, neither party to this Agreement may assign its rights or obligations under this Agreement without the written consent of the other. Any assignment in violation of this provision shall give the non-assigning party the right to terminate this Agreement immediately, upon written notice to the assigning party.

16. AMENDMENTS

Any amendments to this Agreement will be effective only if in writing and signed by District and Integ.

17. ENTIRE AGREEMENT

This Agreement constitutes the entire agreement of the parties with respect to the subject matter hereof.

18. INTERPRETATION

The defined terms used herein are for convenience only and do not limit the contents of this Agreement.

19. NO WAIVER

No waiver of a breach of any provision of this Agreement shall be construed to be a waiver of any breach of any other provision. No delay in acting with regard to any breach of any provision of this Agreement shall be construed to be a waiver of such breach.

20. COMMITMENT OF CURRENT REVENUES ONLY

In the event that, during any term hereof, the Board of Directors of District does not appropriate sufficient funds to meet the obligations of District under this Agreement, then either District or Integ may terminate this Agreement upon ninety (90) days written notice to the other party. District agrees, however, to use its best efforts to secure funds necessary for the continued performance of this Agreement. District and Integ intend this provision to be a continuing right to terminate this Agreement at the expiration of each budget period of each party hereto pursuant to the provisions of Tex. Loc. Govt. Code Ann. §271.903; provided that such termination is not precipitated by any fault of District.

21. VARIATIONS OF PRONOUNS

All pronouns and all variations thereof shall be deemed to refer to the masculine, feminine or neuter, singular or plural, as the identity of the person or persons or entity may require.

22. AUTHORIZATION FOR AGREEMENT

The execution and performance of this Agreement by District and Integ have been duly authorized by all necessary laws, resolutions or corporate action, and this Agreement constitutes the valid and enforceable obligations of Integ and District in accordance with its terms.

IN WITNESS WHEREOF, the parties have caused their names to be hereunto subscribed by a duly authorized officer as of the day and year first above written.

23. TERMINATION OF PREVIOUS CONTRACTS

This agreement replaces any and all previous agreements by and between Hidalgo County Drainage District No. One and Integ, Corp.

Integ:

INTEG, INC.

By:  _____

Godfrey Garza, President

District:

HIDALGO COUNTY DRAINAGE DISTRICT NO. ONE

By:  _____

Juan De Dios Salinas, III, County Judge

APPROVED AS TO FORM:

ATLAS & HALL, L.L.P.

By:  _____

Stephen L. Crain

APPROVED BY
COMMISSIONERS' COURT

ON: 2/6/07

EXHIBIT "A"

For services provided by Integ to District, Integ will be entitled to receive the following compensation, (i) Nine Thousand Five Hundred Dollars (\$9,500.00) per calendar month, for each month during the term of this Agreement, for the general administration and (ii) as compensation for the construction management of the Hidalgo County Master Drainage System Phase II, District shall pay Integ on a semi-annual basis commencing August 1, 2007 one and a half percent of the actual construction costs excluding land acquisition costs of the Hidalgo County Master Drainage System Phase II as calculated by the Financial Officer of District.

In addition to the compensation for services provided to Integ, the District will pay Integ an allowance of \$ 666.00 per month to compensate Integ for the use of Integ's vehicle in connection with the services performed by Integ hereunder, and an allowance of \$100.00 per month to compensate Integ for the use of Integ's cellular telephone in connection with the services performed by Integ hereunder.

EXHIBIT B

EVALUATION CRITERIA

**HIDALGO COUNTY DRAINAGE DISTRICT NO.1
REQUEST FOR QUALIFICATIONS**

“PROFESSIONAL LEGAL SERVICES”

EVALUATION CRITERIA
REQUEST FOR QUALIFICATIONS

Evaluation Criteria

The Statements of Qualifications will be evaluated based on the criteria presented below. These criteria will be scored on the scales shown on the enclosed "RFQ Evaluation Form."

1. Attorney/Firm Qualifications:

a. The attorney/firm should provide the resume of each of the firms' professionals (if applicable) who will be assisting on this project (only if more than one attorney will be providing services). (All attorneys must be licensed to practice in the State of Texas).

b. Civil litigation and contract law specializations or board certifications should also be detailed in each résumé. (Copies of current valid licenses, certifications and registrations should be included in this section and other pertinent information that demonstrates their qualifications to perform the services required.)

2. Experience of Attorney/Firm/Team:

1. The attorney/firm shall demonstrate with detail the minimum 20 years experience in the area of contract and litigation law.

2. The attorney/firm shall demonstrate in detailed writing if exceeding the 20 years experience in the area of contract and litigation law.

The attorney/firm shall designate experienced staff to completely and efficiently perform the services. The designated individuals may not be replaced during the project unless approved by the Drainage District No. 1 Board of Directors. The attorney/firm must state the approach and/or (methodology) in achieving and rendering all services detailed and required.

3. Understanding the Scope of Engagement of Services/Requirements:

The attorney/firm should provide as much background information as to its' experience in providing similar services in connection to contract and litigation law. This should be concise, candid, and limited to no more than 2 pages in length. Please cite at least 5 cases that relate very similar circumstances as to the scope of services and requirements for this project.

4. Term: Commitment to term of Engagement of Attorney/Firm:

The attorney/firm shall state commitment to the term of this engagement (thirty (30) day period) with Drainage District's sole option to extend, if necessary, under the same fees, terms and conditions.

EXHIBIT C

Insurance Requirements

Professional Services

The proposer/applicant awarded the contract shall furnish proof of insurance, which will also include any subcontractor that is subcontracted by the proposer/applicant in at least the following limits, to be in place prior to providing any services under this Contract and to continue at all times in force in effect during the term of this Contract:

1. **Professional liability insurance policy** with limits of at least One Million Dollars (\$1,000,000) per occurrence, or limited to claims made, include at least a five (5) year extended reporting period.
2. **Automobile liability insurance policy** with limits of at least Three Hundred Thousand Dollars (\$300,000.00) per person and Five Hundred Thousand Dollars (\$500,000.00) per occurrence. Coverage should include injury to or death of persons and property damage claims with limits up to Five Hundred Thousand Dollars (\$500,000.00) arising out of the services provided to Drainage District hereunder.
3. **Uninsured/Underinsured motorist coverage** in an amount equal to the bodily injury limits set forth immediately above;
4. **A Five Hundred Thousand Dollars (\$500,000.00) Comprehensive General Liability insurance policy** providing additional coverage to all underlying liabilities of the Drainage District.
5. Workers compensation insurance in amounts established by Texas law, unless the Bidder is specifically exempted from the Texas Workers Compensation Act, Texas Labor Code Chapter 401, et. seq.

Certificates of insurance naming Hidalgo County Drainage District No.1 as an additional insured shall be submitted to the Drainage District for approval prior to any services being performed by Contractor. Each policy of insurance required hereunder shall extend for a period equivalent to, or longer than the term of the Contract, and any insurer hereunder shall be required to give at least thirty (30) days written notice to the Drainage District prior to the cancellation of any such coverage on the termination date, or otherwise. This Contract shall be automatically suspended upon the cancellation, or other termination, of any required policy of insurance hereunder, and such suspension shall continue until evidence adequate replacement coverage is provided to the Drainage District. If replacement coverage is not provided within thirty (30) days following suspension of the Contract, this Contract shall automatically terminate.

Insurance Requirement Acknowledgment

I, _____, authorized representative for _____,
Company /Vendor

hereby acknowledge receipt of the Drainage District's required insurance limits. Said requirements:

- will be acquired within 10 working days after notification from Drainage District of award of project by the Hidalgo County Drainage District No.1 Board of Directors.
- will acquire additional amounts required to meet the Drainage District's requirements within 10 working days after notification from Drainage District of award of project by the Hidalgo County Drainage District No.1 Board of Directors.

Professional Liability (Errors & Omissions): \$ _____

Automobile Liability: \$ _____ General Liability: \$ _____

- have already been met; see attached copy of insurance certificate.

Authorized Representative

Date

Notice to Proposer/Applicant:

A certificate of insurance for the required insurance limits shall be provided to the Drainage District's Contract Managers in order to qualify for award and to execute a contract between your Company and the Hidalgo County Drainage District No.1

Failure to provide Certificates of Insurance to the Drainage District's Contract Managers will cause the award to be rescinded and re-awarded to next qualified vendor. Certificates of Insurance will be monitored and verified on a quarterly basis to ensure coverage policy is in place. It is the District's obligation to maintain the appropriate insurance coverage throughout the term of the contract.

THIS FORM MUST ACCOMPANY YOUR PACKET

PROJECT REQUIREMENTS ACKNOWLEDGMENT

This is to certify that I, _____, possess all of the **APPLICABLE**:

1. Licenses: _____
2. Bonds: _____
3. Certificates: _____
4. Permits: _____
5. Other: _____

Necessary to carry out the required project. Furthermore, I am providing copies of the required documentation so that, if my company is awarded this project, I may be eligible to enter into a letter of engagement with Hidalgo County Drainage District No.1 and proceed to complete the project in term specified.

*** Any licenses, bonds, certificates, permits, etc. which are required must be presented as part of the packet in order to expedite the evaluation process. Failure to provide said documentation will result in the disqualification of your proposal/qualification.**

Authorized Signature

Date

Company

Address

City, State, Zip

AFFIDAVIT
Exhibit "E"

AFFIDAVIT OF NON-COLLUSION NON-CONFLICT OF INTEREST, AND ANTI-LOBBYING

STATE OF TEXAS
COUNTY OF HIDALGO

Affiant, _____, being first duly sworn, deposes that:

(1) Affiant does hereby state neither the Proposer nor any of the Proposer's officers, partners, owners, agents, representatives, employees, or parties in interest, has in any way colluded, conspired, agreed, directly or indirectly with any person, firm, corporation, or other proposer, or potential proposer, to provide any money or other valuable consideration for assistance in procuring or attempting to procure a contract or fix the prices in the attached proposed or the proposal of any other proposer, and further states that no such money or other reward will be hereinafter paid.

(2) Affiant further states they have neither recommended or suggested to Hidalgo County Drainage District No. 1 or any of its Board Directors or Drainage District employees, any of the terms or provisions set forth in their Request for Statement of Qualifications and subsequent agreement, except at a meeting open to all interested proposers, of which proper notice was given.

(3) Affiant, further states their officers, employees, or agents have not, and will not attempt to lobby, directly or indirectly, the Hidalgo County Drainage District Board Meeting between proposal submission date and award by the Hidalgo County Board Directors.

(4) Affiant further states no officer, or stockholder of the Proposer is a member of the staff, or related to any employee of the Hidalgo County Drainage District No. 1 except as noted herein below:

Signature/Title: _____

Subscribed and sworn to before me this _____ day of _____, 2014.

Notary Public

My commission expires: _____, 2014

HISTORICALLY UNDERUTILIZED BUSINESS (HUB) DECLARATION

The primary objective of the Hidalgo County HUB Program is to ensure Historically Underutilized Businesses receive a fair and equal opportunity for participation in the County's procurement process. This fact holds true for Services (Professional & Non-Professional), Commodities, and Construction contracts and any subcontracts thereto. The program strongly encourages Prime Contractors to provide subcontracting opportunities to Certified Hub Contractors/Vendors. Our goal for HUB contractor/vendor participation, as well as HUB subcontractor participation is 30%. To be considered as a "Certified HUB Contractor/Vendor" the contractor/vendor must have been certified by, and hold a current and valid certification with any of the three agencies listed below.

Have you been Certified as a HUB or an MBE/WBE source?: Yes No

If yes, by whom?: State General Services Commission Other

Indicate Certification No(s). _____ or Are Certificate(s) Attached?: Yes No

LIST OF CERTIFIED HUB SUBCONTRACTORS

(Attach additional pages if necessary)

What percentage of the Bid or RFQ is to be subcontracted with Certified HUB sources? _____% (List HUB Subcontractor information below).

HUB Subcontractor Name: _____ HUB Status:
Certifying Agency (Check all applicable): State General Services Commission Other

Address: _____ City: _____ State: _____ Zip:
Contact Person: _____ Title: _____ Phone No.: ()

HUB Subcontractor Name: _____ HUB Status:
Certifying Agency (Check all applicable): State General Services Commission Other

Address: _____ City: _____ State: _____ Zip:
Contact Person: _____ Title: _____ Phone No.: ()
Subcontract Amount: \$ _____ Description of Work to be Performed :

HUB Subcontractor Name: _____ HUB Status:
Certifying Agency (Check all applicable): State General Services Commission Other

Address: _____ City: _____ State: _____ Zip:
Contact Person: _____ Title: _____ Phone No.: ()
Subcontract Amount: \$ _____ Description of Work to be Performed:

**Certification
Regarding Debarment, Suspension and Ineligibility**

As is required by the Federal Regulations Implementing Executive Order 12549, Debarment and Suspension, 45 CFR Part 76, Government-wide Debarment and Suspension, the applicant certifies, to the best of his or her knowledge and belief, that both it and its principals:

- a. Are not presently debarred, suspended, proposed for debarment, declared ineligible, or voluntarily excluded from participation in this transaction by any federal department or agency;
- b. Have not within a three-year period preceding this bid proposal and/or application been convicted of or had a civil judgment rendered against them for commission of fraud or a criminal offense in connection with obtaining, attempting to obtain, or performing a public (federal, state, or local) transaction or contract under a public transaction, violation of federal or state antitrust statutes or commission of embezzlement, theft, forgery, bribery, falsification or destruction of records, making false statements, or receiving stolen property;
- c. Are not presently indicted for or otherwise criminally or civilly charged by a government entity with commission of any of the offenses enumerated herein; and
- d. Have not within a three-year period preceding this bid proposal and/or application had one or more public transactions terminated for cause or default.

Signature: _____
Print Name: _____
Title: _____
Telephone Number: _____
Date: _____

If the bidder is unable to certify to all of the statements in this Certification, such bidder should attach an explanation to this rfq.

C.Approval to set salaries for District Employees and Travel Allowance for Board Members.

On motion by COMMISSIONER PCT. 4, JOSEPH PALACIOS, seconded by COMMISSIONER PCT. 3, JOE M. FLORES, the Board made a UNANIMOUS vote of approval.

Vote: 5 - 0 - Unanimously

D.Adoption of the 2014 Tax Rate.

On motion by COMMISSIONER PCT. 3, JOE M. FLORES, seconded by COMMISSIONER PCT. 1, A.C. CUELLAR, JR., the Board made a UNANIMOUS vote of approval.

Vote: 5 - 0 - Unanimously

The Board proceeded to Item 7.

6. **AI-46732** Pursuant to correspondence received from The Lee Law Firm (on 09-25-14), awarded firm (but as yet no letter of engagement executed) for: Professional Legal Services for the Review and Report of the Agreement between Hidalgo County Drainage District #1 and Integ Corporation" requesting the HCDD#1 Board of Directors consider, discuss, accept and approve, deny or modify, the following language regarding term of service: no less than 30 days no more than 100 days in order to include in final document so as to execute and commence legal employment timeline.

Commissioner Joseph Palacios joined the meeting.

Commissioner A.C. Cuellar, Jr., stated that he thought they had previously approved the terms of service to be 30 days. Mrs. Marty Salazar informed the Board that the Lee Law Firm sent notice requesting a consideration of revision of the terms due to their litigation calendar and other commitments.

Commissioner Joe Flores joined the meeting.

Mrs. Salazar stated that the Board can deny it and go out for bids again. She stated that the process was lengthy and there is no other firm to work with. The Board was in agreement to offer the term of no less than 30 days with no more than 90 days. Mrs. Salazar stated that once they sign the letter of engagement, the time line will commence.

On motion by COMMISSIONER PCT. 3, JOE M. FLORES, seconded by COMMISSIONER PCT. 4, JOSEPH PALACIOS, the Board made a UNANIMOUS vote of approval to modify the term of service to no less than 30 days with no more than 90 days.

Vote: 5 - 0 - Unanimously

The Board proceeded to Item 5.

APPROVED

AI-46732

6.

DRAINAGE DISTRICT

Meeting Date: 09/30/2014

Submitted For: Valde Guerra, HCCC-EO

Submitted By: Marty Salazar, PURCHASING DEPT.

Department: PURCHASING DEPT.

Information

CAPTION

Pursuant to correspondence received from The Lee Law Firm (on 09-25-14), awarded firm (but as yet no letter of engagement executed) for: Professional Legal Services for the Review and Report of the Agreement between Hidalgo County Drainage District #1 and Integ Corporation" requesting the HCDD#1 Board of Directors consider, discuss, accept and approve, deny or modify, the following language regarding term of service: no less than 30 days no more than 100 days in order to include in final document so as to execute and commence legal employment timeline.

BACKGROUND

Attachments

- 1
- 2

Form Review

Inbox	Reviewed By	Date
Purchasing Department	Marty Salazar	09/26/2014 12:39 PM
Budget & Management	Debbie Tamez	09/26/2014 01:29 PM
Auditor's Office	Monica Badillo	09/26/2014 05:04 PM
Form Started By: Marty Salazar		Started On: 09/26/2014 09:53 AM
Final Approval Date: 09/26/2014		

LETTER OF ENGAGEMENT FOR LEGAL SERVICES

RFQ No: HCDD1-14-140-06-04-VYG

Professional Legal Service in connection with the review and report for the agreement between Hidalgo County Drainage District No. 1 and Integ Corporation

This Agreement is made by and between Michael S. Lee/The Lee Firm, A Professional Corporation (“Attorney”), and Hidalgo County Drainage District No. 1 (“Client”) to review and report for the agreement between Hidalgo County Drainage District No. 1 and Integ Corporation.

1. **Scope of Services.** The Attorney will provide legal services as requested by Client and accepted by Attorney on a case-by-case and matter-by-matter assignment. Attorney shall provide those legal services reasonably required to represent Client, and shall keep Client informed of the progress of the case or matter. In order to enable Attorney to render effective legal services, Client shall provide all facts and keep Attorney informed of all developments relating to the matter. Attorney must rely on the accuracy and completeness of the facts and information provided by Client. In addition, Attorney will provide legal services in reviewing all documents related to the contractual issues between Hidalgo County Drainage District No. 1 and Integ Corporation; review appropriate Texas case law, whether statutory and/or common law; conferences and meetings with Hidalgo County Drainage District No. 1 representatives; interviews and conferences with any subcontractors and/or other contractors involved in the project developments that are the subject of the issues between Hidalgo County Drainage District No. 1 and Integ Corporation; interview witnesses; provide appropriate legal opinions relating to same.
2. **Fees.** Hourly fees for legal services are based on the amount of time each lawyer or paralegal spends working on the Client’s behalf multiplied by their respective hourly rate. Hourly rates vary among professionals depending on experience, level of expertise and market conditions. Hourly rates are reviewed annually and will be adjusted only with the Client’s written consent. The fee structure accepted for this matter is stated in the attached Exhibit “A”. Lead counsel and all attorneys and legal staff working on the assigned matter shall be identified in the attached fee structure.
3. **Expenses.** By engaging services from Attorney, Client authorizes third-party contracting necessary for representation on Client’s behalf and such costs shall be reimbursed for actual costs as incurred as per schedule of costs attached as Exhibit “A”, although this list may not be all inclusive. The Attorney will seek approval from Client for any individual expenses that are expected to exceed the sum of \$500.00. Attorney shall also obtain Client’s consent before retaining an outside investigator, consultant or expert witness.
4. **Billing.** The Client shall be billed monthly for fees, costs and expenses incurred (detailed in the attached Exhibit “A”) and will reimburse firm for actual expenses incurred in connection with litigation. The Client shall also pay for the time the Attorney spends traveling, (when necessary). Hourly and/or timed billing shall be submitted in increments of one-tenth (1/10th) of an hour. No block billing shall be accepted. Each billing entry shall separately itemize the activity or task performed and the amount of corresponding time. All billing invoices are subject to review by the County Auditor as provided for under the Texas Local Government Code. Payment of billing invoices requires approval by the Hidalgo County Drainage District No. 1.
5. **Termination.** This agreement will terminate once the case or matter assigned is completely resolved/dismissed, or in the event the Client chooses to terminate the agreement in advance of

completion, resolution or final dismissal of the matter, then upon written notice of termination. The term of service is for no less than 30 days no more than 90 days with the commencement of professional legal employment date of October 13, 2014.

6. Client approval is necessary for settlement. Attorney is authorized to engage in settlement negotiations if and when appropriate in their professional judgment. No settlement of any nature shall be made for any of the claims or causes of action of Client without the complete approval of Client. Upon Client approval, Attorney shall have full authority to sign papers or documents regarding settlement. This provision is subject to the terms and conditions of the policy of insurance that indemnifies Client for the claims in the above matter.
7. Entire Agreement. This Agreement contains the entire understanding and agreement between the parties with respect to its subject matter (*i.e.*, the review and report for the agreement between Hidalgo County Drainage District No. 1 and Integ Corporation) and supersedes any prior or contemporaneous written or oral agreements, representations or warranties between the parties herein.
8. Amendment. This Agreement may be amended only by written amendment with the approval of the Hidalgo County Drainage District No. 1 and their duly authorized agent or representative.
9. Governing Law. This Agreement shall be construed in accordance with the laws of the State of Texas which law shall govern any actions arising hereunder. Any dispute arising hereunder shall be brought before a court of competent jurisdiction in Hidalgo County, Texas.

AGREED:

LAW FIRM:

The Lee Firm, A Professional Corporation

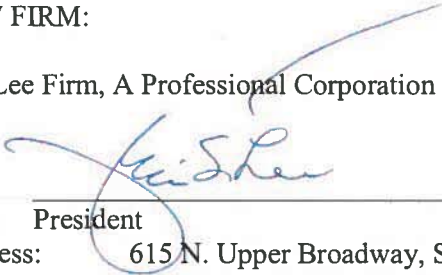
By: 
Title: President
Address: 615 N. Upper Broadway, Suite 708
Corpus Christi, Texas 78401
Telephone: 361.882.4444
Fax: 361.882.7844
E-mail: theleefirmpc@theleefirm.com
Date: October 2, 2014

HIDALGO COUNTY DRAINAGE
DISTRICT NO. 1

By: 
Title: _____
Address: 2812 S. Business Hwy 281
Edinburg, Texas 78539

Approved by Commissioners' Court
on 9/30/2014 RW

Exhibit "A"
**SCHEDULE OF COSTS IN CONNECTION WITH LEGAL REPRESENTATION
 INVOLVING HIDALGO COUNTY DRAINAGE DISTRICT NO. 1
 AND INTGEG CORPORATION**

Attorney Fees: **Hourly Rate:**
 Attorneys: See Attached
 Legal Assistant: See Attached

Legal Fees/Court Costs:

Filing Fees	Actual costs
Service of Process & Subpoenas	Actual costs
Mediation Fees	Actual costs
Legal Research Expenses	Actual costs (Lexis Nexis)
Depositions (Court Reporter & Video as appropriate)	Actual costs
Internet Search Fees	Actual costs
Witness Fees	Actual required by law
Expert Witness Fees	Actual costs
Hearing Transcript Fees (as appropriate)	Actual costs
Investigator Fees (as appropriate)	Actual costs

Travel Expenses:

Mileage Rate (IRS guidelines recommended) – Prevailing IRS Rate
 Air Travel (most economical travel recommended) – Most economical taking into consideration travel time.
 Hotel (most economical recommended – not to exceed \$100.00 per day)
 Meals (to be reimbursed only if traveling out of town – not to exceed \$39.00 per day)

Office Expense:

Faxes	\$1.25 per page
Copies	\$.30 per page
Binding	As charged by Texas Star Documents
Telephone (Long Distance only)	As charged by Foremost

Postage and Express Mail:

U.S. Mail	Actual costs
Express Mail	Actual costs
Other:	
Overnight Delivery	Actual costs

Itemized receipts must be provided for each expense.

Send billing to: Hidalgo County Drainage District No. 1
 ATTN: Evangelina Garcia
 Hidalgo County Purchasing Department
 2812 S. Business Hwy. 281
 Edinburg, Texas 78539
 E-mail: Evangelina.garcia@co.hidalgo.tx.us

CHARGES FOR ATTORNEY FEES AND LEGAL ASSISTANT

Michael S. Lee Senior Attorney	\$250.00 per hour
Peter C. Ruggero Senior Attorney Of Counsel	\$250.00 per hour
Contract Senior Attorney/Of Counsel	\$250.00 per hour
Contract Junior Attorney/Of Counsel	\$200.00 per hour
Senior Paralegal	\$125.00 per hour
Junior Paralegal	\$100.00 per hour
Investigator	\$100.00 per hour
Administrative Tasks	\$75.00 per hour

HIDALGO COUNTY DRAINAGE DISTRICT

“REVIEW AND REPORT AGREEMENT BETWEEN HIDALGO COUNTY DRAINAGE DISTRICT NO. 1 AND INTEG CORP.”

CALENDAR DAYS		
AGREEMENT EFFECTIVE DATE OF OCTOBER 13, 2014		
MONTH	DAYS	HOLIDAY
OCTOBER	18	0
NOVEMBER	30	3-Veteran’s & Thanksgiving Holidays
DECEMBER	31	2-Christmas Holidays
JANUARY	11	1-New Year’s Day
TOTAL OF BUSINESS DAYS	90	6 Holidays
AGREEMENT EXPIRATION		JANUARY 10, 2015-W/O Holidays JANUARY 16, 2015-W/Holidays

BUSINESS DAYS		
AGREEMENT EFFECTIVE DATE OF OCTOBER 13, 2014		
MONTH	DAYS	HOLIDAY
OCTOBER	15	0
NOVEMBER	20	3-Veterans & Thanksgiving Holidays
DECEMBER	23	2-Christmas Holidays
JANUARY	22	2-New Year’s Day & Martin Luther King
FEBRUARY	10	0
TOTAL OF BUSINESS DAYS	90	7 Holidays
AGREEMENT EXPIRATION		FEBRUARY 13, 2015-W/O Holidays FEBRUARY 20, 2015-W/Holidays Credit

Zimbra

evangelina.garcia@co.hidalgo.tx.us

HCDD1-14-140-06-004-VYG

From : The Lee Firm PC <TheLeeFirmPC@theleefirm.com>

Thu, Jan 15, 2015 03:54 PM

Subject : HCDD1-14-140-06-004-VYG 2 attachments**To :** 'Evangelina Garcia' <evangelina.garcia@co.hidalgo.tx.us>**Cc :** 'Martha Salazar' <martha.salazar@co.hidalgo.tx.us>, 'Darlene H. Betancourt' <darlene.betancourt@co.hidalgo.tx.us>, paguilar@ramongarcia-law.com, jaime longoria <jaime.longoria@co.hidalgo.tx.us>

Re: HCDD1-14-140-06-04-VYG

Professional Legal Services - Review and Report - Agreement between Hidalgo County Drainage District No. 1 and Integ Corp.

Ms. Garcia:

Attached please find correspondence dated January 15, 2015 along with the stated enclosure.

Thank you.

Michael S. Lee
The Lee Firm, A Professional Corporation
615 N. Upper Broadway, Suite 708
Corpus Christi, Texas 78401
Telephone: 361.882.4444
Facsimile: 361.882.7844
E-mail Reply to: theleefirmpc@theleefirm.com

MSL/cm

**To Evangelina Garcia 01-15-15.pdf**

199 KB

**Declaration Pages-Prof Liability Ins.pdf**136 KB

615 N UPPER BROADWAY, SUITE 708
CORPUS CHRISTI, TEXAS 78401-0732
TELEPHONE: 361/882-4444

126 W MAIN, SUITE B
P O BOX 599 (MAIL)
KENEDY, TEXAS 78119
TELEPHONE: 830/583-0899

THE LEE FIRM
A PROFESSIONAL CORPORATION
ATTORNEYS AT LAW

TOLL FREE: 800/580-4444
FAX: 361/882-7844
EMAIL: THELEEFIRMP@THELEEFIRM.COM

MICHAEL S LEE
BOARD CERTIFIED
PERSONAL INJURY TRIAL LAW
TEXAS BOARD OF LEGAL SPECIALIZATION

REPLY TO CORPUS CHRISTI ADDRESS

January 15, 2015

Via E-mail – evangelina.garcia@co.hidalgo.tx.us

Evangelina Garcia
Hidalgo County Purchasing Department
2812 S. Business Hwy. 281
Edinburg, Texas 78539

Re: HCDD1-14-140-06-004-VYG
Professional Legal Services - Review and Report-Agreement between Hidalgo County
Drainage District No.1 and Integ Corp.

Dear Ms. Garcia:

1. Unfortunately, 90 days, which would have been “business days only”, is not enough time to complete my evaluation process concerning Integ Corporation (Integ). Due to the Thanksgiving and Christmas Holidays, there were days wherein THE LEE FIRM, A PROFESSIONAL CORPORATION, was not in actual business operation. **In addition, recently I have determined some very serious inconsistencies and “red flags” concerning payment of compensation to Integ that must be addressed. It has been determined that the financial office was advised, by counsel to the Hidalgo County Drainage District, to pay compensation, in relation to Integ, based upon “all costs” incurred in relation to the various drainage projects versus the contract language “actual construction costs”. Steve Crain, partner with ATLAS HALL & RODRIGUEZ LLP, was presented with this issue and he indicates that that is not true and that the compensation should have been paid according to the wording/language in the contract with Integ, *i.e.*, “actual costs” and that this must be an accounting error. As a result, I will be conducting some further interviews, including Steve Crain. Therefore, I need another 60 days. Please ask the Drainage District Board for this additional 60 days for this is a very complicated and serious issue.**

2. Attached is a copy of my professional liability insurance Declaration Sheet.

3. There is no such document in existence entitled “Certificate of Insurance”. I have never seen one in 40 years of practicing law that related to professional liability and legal services rendered.

SATELLITE OFFICES - BY APPOINTMENT ONLY
AUSTIN • GOLIAD • KENEDY

Evangelina Garcia
January 15, 2015
Page 2

If you have any questions, please give me a call.

Yours very truly,

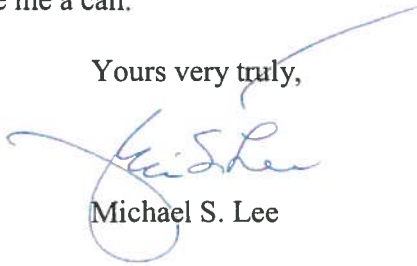
A handwritten signature in blue ink, appearing to read "Michael S. Lee", is written over the typed name. The signature is fluid and cursive, with a large loop at the end.

Michael S. Lee

MSL/cm
Enclosure

cc: Martha Salazar
Via E-mail – martha.salazar@co.hidalgo.tx.us

Darlene H. Bentancourt
Via E-mail – darlene.betancourt@co.hidalgo.tx.us

Ramon Garcia
Via E-mail – paguilar@ramongarcia-law.com

Jaime Longoria
Via E-mail – jaime.longoria@co.hidalgo.tx.us



**LAWYERS PROFESSIONAL LIABILITY POLICY
DECLARATIONS**

Agency:
700324

Branch:
912

Policy Number:
596491751

Insurance is provided by Continental Casualty Company,
333 S. Wabash Ave. Chicago IL 60604
A Stock Insurance Company.

- 1. NAMED INSURED AND ADDRESS:**
 The Lee Firm, PC
 615 N. Upper Broadway, Suite 708
 Corpus Christi, TX 78401

NOTICE TO POLICYHOLDERS:

This is a Claims Made and Reported policy. It applies only to those claims that are both first made against the insured and reported in writing to the Company during the policy period. Please review the policy carefully and discuss this coverage with your insurance agent or broker.

2. POLICY PERIOD:

Inception: 07/28/2014
at 12:01 A.M. Standard Time at the address shown above

Expiration: 07/28/2015

3. LIMITS OF LIABILITY:

Inclusive of Claims Expenses

Each Claim: \$500,000
Aggregate: \$500,000

Death or Disability and Non-Practicing
Extended Reporting Period Limit of Liability:

Each Claim: \$500,000
Aggregate: \$500,000

4. DEDUCTIBLES:

Inclusive of Claims Expenses

Aggregate: \$10,000

5. POLICY PREMIUM:

Annual Premium:

\$5,476.00

Total Amount:

\$5,476.00

Includes CNA Risk Control Credit of

\$ 0.00

Includes Net Protect Premium, see coverage endorsement if applicable

6. FORMS AND ENDORSEMENTS ATTACHED AT INCEPTION:

G-118011-A (Ed. 12/2011), G-118012-A (Ed. 03/1999), G-118016-A (Ed. 12/2011), G-118029-A (Ed. 04/2008), G-145184-A (Ed. 06/2003)

7. WHO TO CONTACT:

To report a claim:
CNA Specialty Claim
P.O. Box 8317 Chicago, IL 60680-8317
Email: LPLNewClaims@cna.com
Fax: 866-419-6308 / Online: www.cna.com/claims
Lawyers Claim Reporting Questions: 800-540-0762

Authorized Representative

08/08/2014

Date



Continental Casualty Company
333 S. Wabash Ave.
Chicago, IL 60604

LAWYERS PROFESSIONAL LIABILITY POLICY

ATTORNEY SCHEDULE

Policy Number: 596491751

Name of Each Lawyer

Michael S. Lee
Peter C. Ruggero

Named Individual Retroactive Date

Same as Policy Retroactive/Prior Acts Date
Same as Policy Retroactive/Prior Acts Date



EACH CLAIM DEDUCTIBLE ENDORSEMENT

In consideration of a premium credit, it is understood and agreed that Item 4 of the Declarations is deleted in its entirety and replaced with the following:

4. DEDUCTIBLE: Each **claim**: \$10000 (inclusive of **claims expenses**)

It is further understood and agreed that Section II, LIMITS OF LIABILITY AND DEDUCTIBLE, the first paragraph of letter C. entitled Deductible, is deleted in its entirety and replaced with the following:

C. Deductible - Each **Claim**

The deductible amount stated in the Declarations for "each **claim**" applies to each and every **claim** made against an **Insured**. It shall be paid by the **Named Insured** and applies to the payment of *damages* and **claims expenses** for **claims** both first made against the **Insured** and reported to the **Company** in writing during the **policy period**. In the event the **Named Insured** fails to pay, the deductible shall be paid jointly and severally by all **Insureds**. The limits of liability set forth in the Declarations are in addition to and in excess of the deductible.

All other terms and conditions of the Policy remain unchanged.

This endorsement, which forms a part of and is for attachment to the Policy issued by the designated Insurers, takes effect on the effective date of said Policy at the hour stated in said Policy, unless another effective date is shown below, and expires concurrently with said Policy.



RETROACTIVE EXCLUSION CLAUSE ENDORSEMENT

It is understood and agreed that Section I, Insuring Agreement, Paragraph A., Coverage, is amended to include a new subparagraph as follows:

- the act or omission occurred on or after 07/28/1994.

All other terms and conditions of the Policy remain unchanged.

This endorsement, which forms a part of and is for attachment to the Policy issued by the designated insurers, takes effect on the effective date of said Policy at the hour stated in said Policy and expires concurrently with said Policy unless another effective date is shown below.

By Authorized Representative _____

(No signature is required if issued with the Policy or if it is effective on the Policy Effective Date)



THIS ENDORSEMENT CHANGES THE POLICY. PLEASE READ IT CAREFULLY.

ECONOMIC AND TRADE SANCTIONS CONDITION

The following condition is added to the Policy:

ECONOMIC AND TRADE SANCTIONS CONDITION

In accordance with laws and regulations of the United States concerning economic and trade embargoes, this policy is void from its inception with respect to any term or condition of this policy that violates any laws or regulations of the United States concerning economic and trade embargoes including, but not limited to the following:

1. Any insured under this Policy, or any person or entity claiming the benefits of such insured, who is or becomes a Specially Designated National or Blocked Person or who is otherwise subject to U.S. economic or trade sanctions;
2. Any claim or suit that is brought in a Sanctioned Country or by a Sanctioned Country Government, where any action in connection with such claim or suit is prohibited by U.S. economic or trade sanctions;
3. Any claim or suit that is brought by any Specially Designated National or Blocked Person or any person or entity who is otherwise subject to U.S. economic or trade sanctions;
4. Property that is located in a Sanctioned Country or that is owned by, rented to or in the care, custody or control of a Sanctioned Country Government, where any activities related to such property are prohibited by U.S. economic or trade sanctions; or
5. Property that is owned by, rented to or in the care, custody or control of a Specially Designated National or Blocked Person, or any person or entity who is otherwise subject to U.S. economic or trade sanctions.

As used in this endorsement a Specially Designated National or Blocked Person is any person or entity that is on the list of Specially Designated Nationals and Blocked Persons issued by the U.S. Treasury Department's Office of Foreign Asset Control (O.F.A.C.) as it may be from time to time amended.

As used in this endorsement a Sanctioned Country is any country that is the subject of trade or economic embargoes imposed by the laws or regulations of the United States of America.

ENDORSEMENT NUMBER: 3
POLICY NUMBER: 596491751
ISSUED TO: The Lee Firm, PC
EFFECTIVE DATE OF ENDORSEMENT: 07/28/2014

This endorsement, which forms a part of and is for attachment to the Policy issued by the designated Insurers, takes effect on the effective date of said Policy at the hour stated in said Policy and expires concurrently with said Policy unless another effective date is shown above.

By Authorized Representative _____
(No signature is required if this endorsement is issued with the Policy or if it is effective on the Policy Effective Date)

Zimbra

evangelina.garcia@co.hidalgo.tx.us

Request for Additional Days on Letter of Engagement to Review/Analyze-Integ Contract for HCDD#1

From : Martha Salazar <martha.salazar@co.hidalgo.tx.us>

Thu, Jan 15, 2015 06:05 PM

Subject : Request for Additional Days on Letter of Engagement to Review/Analyze-Integ Contract for HCDD#1**To** : theleefirm@theleefirm.com**Cc** : Evangelina Garcia <evangelina.garcia@co.hidalgo.tx.us>, Darlene H. Betancourt <darlene.betancourt@co.hidalgo.tx.us>

Hon. Michael Lee:

Attn: Ms. Carolyn:

We are in receipt of your correspondence as well as professional insurance information. Please provide us some clarifications in writing by no later than noon tomorrow, Friday, January 16, 2015 so as to attach to the HCDD#1 agenda item:

1. You are stating that your current letter of engagement is based on "business days" not calendar days which is the customary term for HCDD#1 contracts as well as Hidalgo County. To the best of our knowledge, we do not award based on "business days" for either political subdivision. At your written request, the letter of engagement did state the commencement date of 10-13-14;
2. As it will be up to HCDD#1 Board of Directors to determine how this letter of engagement was awarded (calendar vs. business days basis), please give us your understanding of the expiration date for this current agreement and how that was calculated (as you are indicating "holidays" were involved);
3. HCDD#1 as well as HC had the following holidays granted to it's employees: 2 days for Thanksgiving and 2 days for Christmas and 1 day-New Years Day. That would be 5 total holidays. I would suggest that 5 days be agreed upon (for purposes of calculating the total due to holidays). Whether the Lee Law Firm was not conducting business for more than the 5 days I am recommending, that should not become part of the issue in determining the expiration date of this agreement.
4. As to your "declaration page" for your professional liability insurance, the original Request for Qualifications packet that your firm submitted a Statement of Qualifications clearly details the minimum amount of PL that the District will accept. At no time did your firm object to the amount. You may not be aware, but we have attempted to get this information from your firm since the agreement was awarded. Today we finally received it.

Please provide these clarifications by the date and time indicated herein.

Yours truly,
Martha "Marty" Salazar

Zimbra

evangelina.garcia@co.hidalgo.tx.us

HCDD1-14-140-06-004-VYG

From : The Lee Firm PC <TheLeeFirmPC@theleefirm.com>

Fri, Jan 16, 2015 11:41 AM

Subject : HCDD1-14-140-06-004-VYG 1 attachment**To :** 'Martha Salazar' <martha.salazar@co.hidalgo.tx.us>**Cc :** 'Darlene H. Betancourt' <darlene.betancourt@co.hidalgo.tx.us>, paguilar@ramongarcia-law.com, 'Evangelina Garcia' <evangelina.garcia@co.hidalgo.tx.us>, jaime longoria <jaime.longoria@co.hidalgo.tx.us>

Re: HCDD1-14-140-06-04-VYG

Professional Legal Services - Review and Report - Agreement between Hidalgo County Drainage District No. 1 and Integ Corp.

Ms. Salazar:

Attached please find correspondence dated January 16, 2015.

Thank you.

Michael S. Lee
The Lee Firm, A Professional Corporation
615 N. Upper Broadway, Suite 708
Corpus Christi, Texas 78401
Telephone: 361.882.4444
Facsimile: 361.882.7844
E-mail Reply to: theleefirmpc@theleefirm.com

MSL/cm

**To Martha Salazar 01-16-15.pdf**64 KB

615 N UPPER BROADWAY, SUITE 708
CORPUS CHRISTI, TEXAS 78401-0732
TELEPHONE: 361/882-4444

126 W MAIN, SUITE B
P O BOX 599 (MAIL)
KENEDY, TEXAS 78119
TELEPHONE: 830/583-0899

THE LEE FIRM
A PROFESSIONAL CORPORATION
ATTORNEYS AT LAW

TOLL FREE: 800/580-4444
FAX: 361/882-7844
EMAIL: THELEEFIRMP@THELEEFIRM.COM

MICHAEL S LEE
BOARD CERTIFIED
PERSONAL INJURY TRIAL LAW
TEXAS BOARD OF LEGAL SPECIALIZATION

REPLY TO CORPUS CHRISTI ADDRESS

January 16, 2015

Via E-mail – martha.salazar@co.hidalgo.tx.us

Martha Salazar
Hidalgo County Purchasing Department
2812 S. Business Hwy. 281
Edinburg, Texas 78539

Re: HCDD1-14-140-06-004-VYG
Professional Legal Services - Review and Report-Agreement between Hidalgo County
Drainage District No.1 and Integ Corp.

Dear Ms. Salazar:

1. THE LEE FIRM, A PROFESSIONAL CORPORATION, is not a “governmental” employee and therefore we do not calendar any of our business days in relation to same. Remember, when I was first requested to proceed forward with an evaluation process of the Integ Corp. contract I requested 120 days knowing that I would be faced with the Thanksgiving and Christmas Holidays as well as other pretrial court scheduling. Sorry for any confusion. **Notwithstanding, if the Hidalgo County Drainage District No. 1 (District) wants a complete evaluation and analysis, I need another 60 days. Although I started with two notebook binders, I now have approximately five to six and there have been at least 2,000 pages received, scanned, reviewed, Bates stamped and placed in appropriate indexes. On the other hand, if the District wants a “quickie”, then I will do it in 30 days. As advised, this is a very complex and serious matter and as a result of recent developments, it has become even more complicated. Please advise.**

2. In the interview and application process, I advised that I had a professional liability insurance policy in the amount of \$500,000.00 and “it had been accepted by Hidalgo County on another case”. Therefore, I was under the impression that it would be satisfactory ... **due to the fact that I was giving the District a discount rate. If you want me to get a \$1Million professional liability insurance policy, I can get an oral binder today; however, all of my rates will be increased to the regular rates to achieve this request. Please advise.**

3. As to a Certificate of Insurance, I have never seen that in relation to professional liability insurance. None exists.

SATELLITE OFFICES - BY APPOINTMENT ONLY
AUSTIN • GOLIAD • KENEDY

Martha Salazar
January 16, 2015
Page 2

Ms. Salazar, it is appalling as to what I have discovered in relation to the District's management of the various projects and monies that are the subject of same. Notwithstanding, I will wait for your response.

Thank you for your professionalism.

Yours very truly,

Michael S. Lee

P.S. Please send me a copy of the contract with Stephen Crain/ATLAS HALL & RODRIGUEZ LLP as well as his Declaration Page and if one exists, a Certificate of Insurance.

Thanks.

MSL/cm

cc: Evangelina Garcia
Via E-mail – evangelina.garcia@co.hidalgo.tx.us

Darlene H. Bentancourt
Via E-mail – darlene.betancourt@co.hidalgo.tx.us

Ramon Garcia
Via E-mail – paguilar@ramongarcia-law.com

Jaime Longoria
Via E-mail – jaime.longoria@co.hidalgo.tx.us

Zimbra

evangelina.garcia@co.hidalgo.tx.us

Fwd: HCDD1-14-140-06-004-VYG**From :** Martha Salazar <martha.salazar@co.hidalgo.tx.us>

Fri, Jan 16, 2015 12:24 PM

Subject : Fwd: HCDD1-14-140-06-004-VYG 1 attachment**To :** theleefirm@theleefirm.com, Ramon Garcia <ramon.garcia@co.hidalgo.tx.us>**Cc :** Darlene H. Betancourt <darlene.betancourt@co.hidalgo.tx.us>, Evangelina Garcia <evangelina.garcia@co.hidalgo.tx.us>, Jaime Longoria <jaime.longoria@co.hidalgo.tx.us>

Hon. Michael Lee:

The issues you are bringing to the HCDD#1-BOD will be discussed and applicable and necessary action taken on Tuesday, January 20, 2015. It is my recommendation that you attend the meeting which commences at 9:00 am. I am sure the BOD will have questions that need to be addressed only by your firm.

1. Be prepared to advise the BOD what is your calculated expiration date of this current 90 day engagement (i.e. "business vs. calendar days basis). As I noted in last night's e-mail, the commencement date is not in issue-October 13, 2014;

2. The BOD will decide as to your \$500K PL coverage is acceptable to this project and if the "declaration page" is sufficient as to confirmation of coverage;

3. Your request for information regarding Hon. Steve Crain is a Public Information Request and must be submitted in that form to the appropriate department: Pubic Affairs Division at public.info@co.hidalgo.tx.us with POC Ms. Julia Sullivan at julia.sullivan@co.hidalgo.tx.us ; and Ms. Hilda Salinas at hilda.salinas@co.hidalgo.tx.us respectively.

I have an agenda item (as stated herein) for HCDD#1 Board of Directors meeting of Tuesday, January 20, 2015 commencing at 9:00 AM located at City of Edinburg Commission Chambers.

Yours truly,

Martha "Marty" Salazar

----- Forwarded Message -----

From: "The Lee Firm PC" <TheLeeFirmPC@theleefirm.com>

To: "Martha Salazar" <martha.salazar@co.hidalgo.tx.us>

Cc: "Darlene H. Betancourt" <darlene.betancourt@co.hidalgo.tx.us>, paguilar@ramongarcia-law.com, "Evangelina Garcia" <evangelina.garcia@co.hidalgo.tx.us>, "jaime longoria" <jaime.longoria@co.hidalgo.tx.us>

Sent: Friday, January 16, 2015 11:41:05 AM

Subject: HCDD1-14-140-06-004-VYG

Re: HCDD1-14-140-06-04-VYG

Professional Legal Services - Review and Report - Agreement between Hidalgo County Drainage District No. 1 and Integ Corp.

Ms. Salazar:

Attached please find correspondence dated January 16, 2015.

Thank you.

Michael S. Lee

The Lee Firm, A Professional Corporation

615 N. Upper Broadway, Suite 708

Corpus Christi, Texas 78401

Telephone: 361.882.4444

Facsimile: 361.882.7844

E-mail Reply to: theleefirm@theleefirm.com

MSL/cm

Insurance Requirement Acknowledgment

I, Michael S. Lee, authorized representative for The Lee Firm, A Professional Corporation
Company /Vendor

hereby acknowledge receipt of the Drainage District's required insurance limits. Said requirements:

- will be acquired within 10 working days after notification from Drainage District of award of project by the Hidalgo County Drainage District No.1 Board of Directors.
- will acquire additional amounts required to meet the Drainage District's requirements within 10 working days after notification from Drainage District of award of project by the Hidalgo County Drainage District No.1 Board of Directors.

Professional Liability (Errors & Omissions): \$ _____

Automobile Liability: \$ _____ General Liability: \$ _____

- have already been met; see attached copy of insurance certificate.



Authorized Representative

May 30, 2014

Date

Notice to Proposer/Applicant:

A certificate of insurance for the required insurance limits shall be provided to the Drainage District's

Contract Managers in order to qualify for award and to execute a contract between your Company and the

Hidalgo County Drainage District No.1

Failure to provide Certificates of Insurance to the Drainage District's Contract Managers will cause the award to be rescinded and re-awarded to next qualified vendor. Certificates of Insurance will be monitored and verified on a quarterly basis to ensure coverage policy is in place. It is the District's obligation to maintain the appropriate insurance coverage throughout the term of the contract.

THIS FORM MUST ACCOMPANY YOUR PACKET

AI -48166

13.

DRAINAGE DISTRICT

Meeting Date: 01/20/2015

Submitted By: Claudette Guerrero,
DRAINAGE DISTRICT

Department: DRAINAGE DISTRICT

Information

CAPTION

Request approval to issue manual payment after review and audit procedures are complete on the following items:

A. Application for Payment No. 1 in the amount of \$161,405.00 from Foremost Paving, Inc. related to Construction Contract no. HCDD1-14-025-09-09-Mission Inlet Arch Culvert-Aluminum Liner Plate Reline. PO#625593. Project Engineer: R. Gutierrez Engineering Corp.

B. Application for Retainage Release in the amount of \$8,495.00 from Foremost Paving, Inc. related to Construction Contract no. HCDD1-14-025-09-09-Mission Inlet Arch Culver-Aluminum Liner Plate Reline. PO#625593. Project Engineer: R. Gutierrez Engineering Corp.

C. Application for Payment No. 1 in the amount of \$150,255.80 from Rojas Construction & Paving related to Construction Contract No. HCDD1-13-021-04-29B. PO#625108-14. Project Engineer: R. Gutierrez Engineering Corp.

BACKGROUND

Fiscal Impact

Attachments

Foremost Pmt#1 Arch

Foremost Retainage Release ARch

Rojas Pmt#1-FM495 Wisconsin

DD1 PE LTR FOREMOST PMT#-ARCH

DD1 PE LTR FOREMOST RETAINAGE RELEASE -ARCH

DD1 PE LTR ROJAS PMT#1-FM495 WISCONSIN

Form Review

Inbox	Reviewed By	Date
Budget & Management	Veronica Ortiz	01/16/2015 02:28 PM
Final Approval	Monica Badillo	01/16/2015 06:31 PM
Form Started By: Claudette Guerrero		Started On: 01/16/2015 01:02 PM
Final Approval Date: 01/16/2015		

HIDALGO COUNTY DRAINAGE DISTRICT NUMBER ONE

902 NORTH DOOLITTLE

EDINBURG, TEXAS 78542

(956) 292-7080

FAX (956) 292-7089



GODFREY GARZA, JR.
MANAGER

INVOICE PROCESSING CHECKLIST

Date Received: 12/22/2014

Engineer/Firm Name: Foremost Paving, Inc.

Project Name/Number: Mission Inlet Arch Culvert-Aluminum Liner Plate

Invoice No: PMT # 1 Re-Line

Logged in and Scanned: 221PM 12/23 By: R. Arce Forwarded to: Joey Garza

Engineer	Name	Date	Comment
Scope of work reviewed			

Accounting	Name	Date	Comment
Encumbrance			
Purchase Order Attached			
Audit			
Final Approval for Agenda			

	Name	Date	Comment
Placed on Agenda			

Additional Comments: _____

APPLICATION FOR PMT #1

To: Hidalgo County Drainage District No. 1 (OWNER)
 From: Foremost Paving, Inc. (CONTRACTOR)
 Contract: HCDD1-14-025-09-09
 Project: MISSION INLET ARCH CULVERT- ALUMINUM LINER PLATE RELINE
 OWNER's Contract No. HCDD1-14-025-09-09
 For Work accomplished through the date of: November 22, 2014 ENGINEER's Project No.: ENG14.007

1. Original Contract Price:	\$	169,900.00
2. Net change by Change Orders and Written Agreements (+ or -):	\$	-
3. Current Contract Price (1 plus 2):	\$	169,900.00
4. Total completed and stored to date:	\$	169,900.00
5. Retainage (per Agreement):		
<u>5% of completed Work:</u>	\$	8,495.00
<u>5% of stored material:</u>	\$	-
Total Retainage:		\$ 8,495.00
6. Total completed and stored to date less retainage (4 minus 5):	\$	161,405.00
7. Less previous Application for Payments:	\$	-
8. Balance to Finish:	\$	-
9. AMOUNT DUE THIS APPLICATION (6 MINUS 7):	\$	161,405.00

Accompanying Documentation:

CONTRACTOR'S Certification:
 The undersigned CONTRACTOR certifies that (1) all previous progress payments received from OWNER on account of Work done under the Contract referred to above have been applied on account to discharge CONTRACTOR's legitimate obligations incurred in connection with Work covered by prior Applications for Payment numbered 1 through PMT #1 inclusive; (2) title of all Work, materials and equipment incorporated in said Work or otherwise listed in or covered by this Application for Payment will pass to OWNER at time of payment free and clear of all Liens, security interests and encumbrances (except such as are covered by a Bond acceptable to OWNER indemnifying OWNER against any such Lien, security interest or encumbrance); and (3) all Work covered by this Application for Payment is in accordance with the Contract Documents and not defective.

Dated 12/4/14 Foremost Paving, Inc.

 CONTRACTOR
 By: 

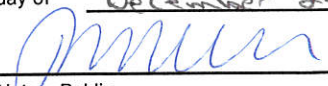
State of Texas
 County of Hidalgo
 Subscribed and sworn to before me this 4th
 day of December 2014

 Notary Public
 My Commission expires: March 19, 2018



Payment of the above AMOUNT DUE THIS APPLICATION is recommended.

Dated _____ R. GUTIERREZ ENGINEERING CORPORATION

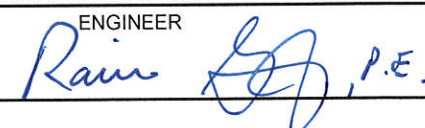
 ENGINEER
 By:  P.E.

Schedule of Values

Contractor Name: Foremost Paving, Inc.
 Starting Date: October 22, 2014
 Project Ending Date: December 20, 2014
 Project Desc: MISSION INLET ARCH CULVERT - ALUMINUM LINER PLATE RELINE
 Retainage Percent: 5%

Application: PMT #1
 Application Date: 11/22/2014
 Period To: ENG14.007
 Engineer's Project No.: R. Gutierrez Eng. Corp.
 Engineer Firm

Summary										
Contract Number	Description	Original Schedule Value	Application #1	Retainage for App #1	Payment for Application #1	Total Completed to Date	Retainage to Date	Total Completed Less Retainage	Previous Payments	Balance To Finish
HCDD1-14-025-09-09	MISSION INLET ARCH CULVERT- ALUMINUM LINER PLATE RELINE	\$ 169,900.00	\$ 169,900.00	\$ 8,495.00	\$ 161,405.00	\$ 169,900.00	\$ 8,495.00	\$ 161,405.00	\$ -	\$ -
	TOTALS:	\$ 169,900.00	\$ 169,900.00	\$ 8,495.00	\$ 161,405.00	\$ 169,900.00	\$ 8,495.00	\$ 161,405.00	\$ -	\$ -



FOREMOST PAVING, INC.

P.O. BOX 29 WESLACO, TEXAS 78599-0029

December 2, 2014

Mr. Ramiro Gutierrez, P.E.
R. Gutierrez Engineering Corporation.
130 E. Park Ave.
Pharr, Tx 78577

Re: Mission Inlet Arch Culvert – Aluminum Liner Plate Re-Line Project

Dear Mr. Gutierrez,

Following is a list of suppliers used on the above-mentioned project:

- 1) Contech 16445 Collections Center Dr Chicago, Il 60693
 (210) 737-1112
- 2) Rio Grande Steel P.O. Box 5178 McAllen, Tx 78502
 (956) 702-4434
- 3) Cemex 3710 S. Expressway 281 Edinburg, Tx 78539
 (956) 386-1452

If I can be of additional service, please feel free to contact me.

Sincerely,

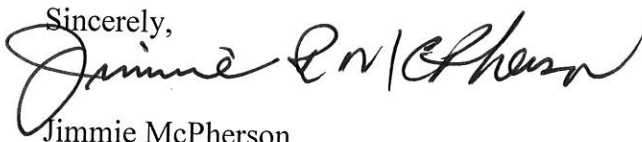

Jimmie McPherson



Job # 14009609

CONDITIONAL WAIVER AND RELEASE ON PROGRESS PAYMENT

Project: Mission Inlet Arch Culvert - Aluminum Liner Plate Re-Line

Job: SMCOOL & RANCHO RD

On receipt by the signer of this document of a check from FOREMOST PAVING INC. of \$6,306.17 payable to CEMEX (payee or payees of check) and when the check has been properly endorsed and has been paid by the bank on which it is drawn, this document becomes effective to release any mechanic's lien right, any right arising from a payment bond that complies with a state or federal statute, any common law payment bond right, any claim for payment, and any rights under any similar ordinance, rule, or statute related to claim or payment rights for persons in the signer's position that the signer has on the property of Hidalgo Co. Drainage Dist. No. 1_ (owner) located at 100 E Cano St., Edinburg, TX 78539(location) to the following extent _New Construction, Repairs or Improvements to: Mission Inlet Arch Culvert - Aluminum Liner Plate Re-Line (job description).

This release covers a progress payment for all labor, services, equipment, or materials furnished to the property or to FOREMOST PAVING INC. (person with whom signer contracted) as indicated in the attached statement(s) or progress payment request(s), except for unpaid retention, pending modifications and changes, or other items furnished.

Before any recipient of this document relies on this document, the recipient should verify evidence of payment to the signer. The signer warrants that the signer has already paid or will use the funds received from this progress payment to promptly pay in full all of the signer's laborers, subcontractors, materialmen, and suppliers for all work, materials, equipment, or services provided for or to the above referenced project in regard to the attached statement(s) or progress payment request(s).

Company Name: CEMEX

Date 12/17/14

By: Teri Clay

Title: Sr. Credit Representative

Signature: *Teri Clay*

STATE OF TEXAS §
 §
COUNTY OF HARRIS §

This instrument was acknowledged before me on the 17th day of December, 2014, by Teri Clay, Sr. Credit Representative of CEMEX, for the consideration herein expressed, on behalf of same.

Sandy Leng
Notary Public in and for the
STATE OF TEXAS



PARTIAL/FINAL WAIVER OF LIEN

THE STATE OF TEXAS

COUNTY OF Hidalgo

The undersigned contracted with Rio Grande Steel Ltd.
to furnish Reinforcing Steel
in connection with certain improvements to real property located in Hidalgo
County, Texas, and owned by Hidalgo Co. Drainage Dist No 1
Which improvements are described as follows:

Mission Inlet Arch Culvert - Aluminum Liner Plate Red line

In consideration of Pay Estimate No. _____ in the amount of _____
DOLLARS (and other good and

valuable consideration, the receipt and sufficiency of which is hereby acknowledged and certified, the undersigned does hereby waive and release any mechanic's lien or materialman's lien or claims of lien that the undersigned and/or hereafter has or the above mentioned real property or portion of any labor performed or materials furnished or to be furnished or labor performed and materials furnished by the undersigned pursuant to the above-mentioned contract or any constitutional lien that the undersigned may have.

Undersigned hereby guarantees that all bills for labor performed and/or materials furnished in connection with the construction of such improvements on the Property have been fully paid and satisfied and I hereby guarantee that if for any reason a lien or liens are filed for material or labor against said Property for the purpose of for material or labor in connection with the erection or construction of said improvement the undersigned shall obtain a settlement of such lien or liens and a proper release thereof shall be obtained.

Rio Grande Steel Ltd.
CONTRACTOR

BY: [Signature]
TITLE

SWORN TO AND SUBSCRIBED BEFORE ME, on this 5th day of Dec 2014
certify which witness my hand and seal of office.

My Commission Expires: 5-14-16
[Signature]
NOTARY PUBLIC in and for the State of _____

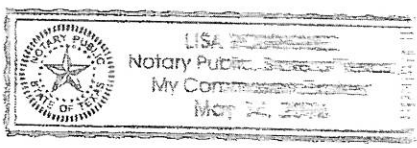

PARTIAL/FINAL WAIVER OF LIEN

THE STATE OF TEXAS

COUNTY OF Hidalgo

The undersigned contracted with FOLLETT MOST PAVING to furnish LINER PLATE & SERVICES in connection with certain improvements to real property located in Hidalgo County, Texas, and owned by Hidalgo Co. Drainage Dist No. 1 Which improvements are described as follows:

Mission Inlet Arch Culvert - Aluminum Liner Plate Re-Line

In consideration of Pay Estimate No. _____ in the amount of \$48,795.00 DOLLAR(\$ 48,795) and other good and valuable consideration, the receipt and sufficiency of which is hereby acknowledged and confessed, the undersigned does hereby waive and release any mechanic's lien or materialmen's lien or claims of lien that the undersigned has or hereafter has on the above mentioned real property on account of any labor performed or materials furnished or to be furnished or labor performed and materials furnished by the undersigned pursuant to the above-mentioned contract or any constitutional lien that the undersigned may have.

Undersigned hereby guarantees that all bids for labor performed and/or materials furnished in the erection and construction of such improvements on the Property have been fully paid and satisfied and Undersigned does further guarantee that if for any reason a lien or liens are filed for material or labor against said Property arising out of any bills for material or labor in connection with the erection or construction of said improvements thereon. Undersigned will obtain a settlement of such lien or liens and a proper release thereof shall be obtained.

[Signature]
CONTRACTOR

BY: CRED TRIP
TITLE

SWORN TO AND SUBSCRIBED BEFORE ME, on this the 11 day of DECEMBER 2014 to certify which witness my hand and seal of office.

Anita Pitcher
NOTARY PUBLIC in and for the State of Texas Ohio

My Commission Expires: 6-14-19



This release applies only to the extent of the amount shown above and is conditional upon all checks clearing appropriate banks before the document becomes active

Exhibit E-1

PARTIAL/FINAL WAIVER OF LEIN

THE STATE OF TEXAS

COUNTY OF Hidalgo

The undersigned contracted with Hidalgo County Drainage Dist. No. 1
to furnish Aluminum Liner Plate Re-Line
in connection with certain improvements to real property located in Hidalgo
County, Texas, and owned by Hidalgo Co. Drainage Dist No. 1
Which improvements are described as follows:

Mission Inlet Arch Culvert - Aluminum Liner Plate Re-Line

In consideration of Pay Estimate No 1 in the amount of One Hundred Sixty Nine
Thousand DOLLAR(\$ 169,000.00)and other good and

valuable consideration, the receipt and sufficiency of which is hereby acknowledged and confessed, the undersigned does hereby waive and release any mechanic's lien or materialmen's lien or claims of lien that the undersigned has or hereafter has on the above mentioned real property on account of any labor performed or materials furnished or to be furnished or labor performed and materials furnished by the undersigned pursuant to the above-mentioned contract or any constitutional lien that the undersigned may have.

Undersigned hereby guarantees that all bids for labor performed and/or materials furnished in the erection and construction of such improvements on the Property have been fully paid and satisfied and Undersigned does further guarantee that if for any reason a lien or liens are filed for material or labor against said Property arising out of any bills for material or labor in connection with the erection or construction of said improvements thereon, Undersigned will obtain a settlement of such lien or liens and a proper release thereof shall be obtained.

CONTRACTOR

BY: Employee
TITLE

SWORN TO AND SUBSCRIBED BEFORE ME, on this the 24th day of Nov, 2014to
certify which witness my hand and seal of office.

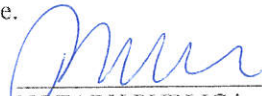
NOTARY PUBLIC in and for the State of Texas

My Commission Expires: March 19, 2018



Contract Time Statement

MISSION INLET ARCH CULVERT- ALUMINUM LINER PLATE RELINE

PAY REQUEST 1 CONTRACTOR Formost Paving, Inc.

PROJECT NO. HCDD1-14-025-09-09 City McAllen, TX DATE WORK BEGAN 10/22/2014

TIME COMPUTED FROM 10/22/2014 DATE WORK COMPLETED _____

MONTH	DATE OR DAYS	WORKING DAYS	DAYS CREDITED	DESCRIPTION
September	24			Pre-Construction Meeting & Notice to Proceed Issued with start date being 4 weeks from today.
October	1			
	2			
	3			
	4			
	5			
	6			
	7			
	8			
	9			
	10			
	11			
	12			
	13			
	14			
	15			
	16			
	17			
	18			
	19			
	20			
	21			
	22	1		Contract time starts as per Notice To Proceed issued on 9/24/2014
	23	1		No work done
	24	1		No work done
	25	1		Weekend - No work done
	26	1		Weekend - No work done
	27	1		Work on project
	28	1		Work on project
	29	1		Work on project
	30	1		Work on project
	31	1		Work on project
TOTALS		10	0	

NO. OF CONTRACT CALANDER DAYS 60 NO. CALANDER DAYS CHARGED TO DATE 10

ASSESSED LIQUIDATED DAMAGES: NO. DAYS 0 PER DAY \$ _____ TOTAL _____

CERTIFIED AS CORRECT (ONE COPY HAS BEEN GIVEN TO THE CONTRACTOR) _____
Rain [Signature], P.E.
PROJECT ENGINEER

INSTRUCTIONS: PROJECT IDENTIFICATION SHOULD COVER CONTRACT. TIME CREDITED AND REASONS THEREFORE MUST CONFORM TO PROVISIONS OF CONTRACT. NO HOLIDAY CREDIT ALLOWED FOR DAYS PRECEDING OR FOLLOWING LEGAL HOLIDAYS. TIME SUSPENDED AND RESUMED MUST BE SUPPORTED BY COPY EACH OF LETTERS TO CONTRACTOR DATED ON OR BEFORE EFFECTIVE DATES. TIME EXTENSION MUST BE INDICATED AND REFERENCED TO RELATED PROVISION OF CONTRACT. SEE BOOKLET OF INSTRUCTIONS, CONSTRUCTION ESTIMATES DATED SEPTEMBER 1, 1956

Contract Time Statement

MISSION INLET ARCH CULVERT- ALUMINUM LINER PLATE RELINE

PAY REQUEST 1 CONTRACTOR Formost Paving, Inc.

PROJECT NO. HCDD1-14-025-09-09 City McAllen, TX DATE WORK BEGAN 10/22/2014

TIME COMPUTED FROM 10/22/2014 DATE WORK COMPLETED _____

MONTH	DATE OR DAYS	WORKING DAYS	DAYS CREDITED	DESCRIPTION
November	1	1		Weekend - No work done
	2	1		Weekend - No work done
	3	1		Work on project
	4	1		Work on project
	5	1	1	Work on project & rain out
	6	1	1	Work on project & rain out
	7	1	1	No work done - Rain / Too wet to work
	8	1	1	Weekend - Rain / Too wet to work
	9	1	1	Weekend - Rain / Too wet to work
	10	1		Work on project
	11	1		Work on project - work on punch list with TXDOT inspector
	12	1		No work done
	13	1		No work done
	14	1		No work done
	15	1		Weekend - No work done
	16	1		Weekend - No work done
	17	1		No work done
	18	1		No work done
	19	1		No work done
	20	1		Final walkthrough - Project substantially complete - Time stops
	21			
	22			Weekend - No work done
	23			Weekend - No work done
	24			
	25			
	26			
	27			
	28			
	29			
	30			
TOTALS		20	5	

NO. OF CONTRACT CALANDER DAYS 60 NO. CALANDER DAYS CHARGED TO DATE 30

ASSESSED LIQUIDATED DAMAGES: NO. DAYS 0 PER DAY \$ _____ TOTAL _____

CERTIFIED AS CORRECT (ONE COPY HAS BEEN GIVEN TO THE CONTRACTOR) Ram [Signature] P.E.
PROJECT ENGINEER

INSTRUCTIONS: PROJECT IDENTIFICATION SHOULD COVER CONTRACT. TIME CREDITED AND REASONS THEREFORE MUST CONFORM TO PROVISIONS OF CONTRACT. NO HOLIDAY CREDIT ALLOWED FOR DAYS PRECEDING OR FOLLOWING LEGAL HOLIDAYS. TIME SUSPENDED AND RESUMED MUST BE SUPPORTED BY COPY EACH OF LETTERS TO CONTRACTOR DATED ON OR BEFORE EFFECTIVE DATES. TIME EXTENSION MUST BE INDICATED AND REFERENCED TO RELATED PROVISION OF CONTRACT. SEE BOOKLET OF INSTRUCTIONS, CONSTRUCTION ESTIMATES DATED SEPTEMBER 1, 1956

15609

Date 10/30/14

I, LUCY R. CABALLERO PAYROLL ADMINISTRATOR do hereby state:
(Name of signatory party) (Title)

(1) That I pay or supervise the payment of the persons employed by FOREMOST PAVING on
the MISSION INLET ARCH; that during the payroll period commencing on the 19 day of October 2014
(Building or work)

and ending the 25 day of October 2014 all persons employed on said project have been paid the full
weekly wages earned, that no rebates have been or will be made either directly or indirectly to or on behalf of said
FOREMOST PAVING from the full weekly wages earned by any person and that no deductions have

(Contractor or subcontractor)
been made either directly or indirectly from the full wages earned by any person, other than permissible deductions as defined
in Regulations, Part 5 (29 CFR Subtitle A), issued by the Secretary of Labor under the Copeland Act, as amended (48 Stat. 948;
63 Stat. 108; 72 Stat. 967; 76 Stat. 357; 40 U.S.C. 27 6c), and described below:

(2) That any payrolls otherwise under this contract required to be submitted for the above period are correct and complete:
that the wage rates for laborers or mechanics contained therein are not less than the applicable wage rates contained in any wage
determination incorporated into the contract: that the classifications set forth therein for each laborer or mechanic conform with
the work he performed.

(3) That any apprentices employed in the above period are duly registered in a bona fide apprenticeship program registered
with a State apprenticeship agency recognized by the Bureau of Apprenticeship and Training, United States Department of Labor
or if no such recognized agency exists in a State, are registered with the Bureau of Apprenticeship and Training, United States
Department of Labor

(4) That:

(a) WHERE FRINGE BENEFITS ARE PAID TO APPROVED PLANS, FUNDS, OR PROGRAMS

In addition to the basic hourly wage rates paid to each laborer or mechanic listed in the above referenced
payroll, payments of fringe benefits as listed in the contract have been or will be made to appropriate programs
for the benefit of such employees, except as noted in Section 4(c) below.

(b) WHERE FRINGE BENEFITS ARE PAID IN CASH

Each laborer or mechanic listed in the above referenced payroll has been paid as indicated on the payroll, an
amount not less than the sum of the applicable basic hourly wage rate plus the amount of the required fringe
benefits as listed in the contract, except as noted in section 4(c) below.

(c) EXCEPTIONS

EXCEPTION (CRAFT)	EXPLANATION

REMARKS

NAME AND TITLE: LUCY R. CABALLERO SIGNATURE: Lucy R. Caballero
PAYROLL ADMINISTRATOR

THE WILLFUL FALSIFICATION OF ANY OF THE ABOVE STATEMENTS MAY SUBJECT THE CONTRACTOR OR SUBCONTRACTOR TO CIVIL OR CRIMINAL
PROSECUTION. SEE SECTION 1001 OF TITLE 18 AND SECTION 251 OF TITLE 31 OF THE UNITED STATES CODE.

FOREMOST PAVING
POST OFFICE BOX 29
WESLACO

CONTRACTOR _____ CONTRACT NO _____
OR SUBCONTRACTOR _____
, TX 78599

PROJECT: 15609 MISSION INLET ARCH
AND LOCATION: STRUCTURE
WAGE DECISION: 000000000000

PAYROLL NO _____ FOR WEEK ENDING 10/25/14

EMPLOYEE NAME, ADDRESS, SOCIAL SECURITY NUMBER AND WORK CLASSIFICATION	SUN 10/19	MON 10/20	TUE 10/21	WED 10/22	THU 10/23	FRI 10/24	SAT 10/25	TOTAL HOURS	GROSS - D E D U C T I O N S--				CHECK NO NET WAGES
									EARNED THIS JOB/	FED WH FICA STATE	SDI LTX. OTHER	TOTAL DED- CTIONS	

SSN: 1224 # DEPS: 5 Work Class: 1172 - 1172

ALEJANDRO . CHAVEZ	OT	.00	.00	.00	.00	.00	2.50	.00	2.50					
	ST	.00	.00	.00	.00	.00	.00	.00		37.50	14.19	.00		128759
	RATE	.000	.000	.000	.000	.000	10.000	.000	2.50	565.00	43.22	.00		
	SUBSIS.	.00	.00	.00	.00	.00	.00	.00			.00	.00	57.41	507.59

SEX: M

SSN: 3489 # DEPS: 2 Work Class: 1172 - 1172

FEDERICO R. GARZA	OT	.00	.00	.00	.00	.00	2.00	.00	2.00					
	ST	.00	.00	.00	.00	.00	.00	.00		30.00	45.62	.00		128760
	RATE	.000	.000	.000	.000	.000	10.000	.000	2.00	557.50	42.65	.00		
	SUBSIS.	.00	.00	.00	.00	.00	.00	.00			.00	.00	88.27	469.23

SEX: M

SSN: 1317 # DEPS: 0 Work Class: 1124 - 1124

LUIS H. GUTIERREZ	OT	.00	.00	.00	.00	.00	2.50	.00	2.50					
	ST	.00	.00	.00	3.00	.00	.00	.00	3.00	85.73	127.22	.00		128761
	RATE	.000	.000	.000	12.700	.000	12.700	.000	5.50	850.90	63.57	.00		
	SUBSIS.	.00	.00	.00	.00	.00	.00	.00			.00	29.57	220.36	630.54

SEX: M

SSN: 7940 # DEPS: 2 Work Class: 1175 - 1175

ELEAZAR . RANGEL	OT	.00	.00	.00	.00	.00	2.00	.00	2.00					
	ST	.00	.00	.00	3.00	.00	.00	.00	3.00	78.00	43.74	.00		128763
	RATE	.000	.000	.000	13.000	.000	13.000	.000	5.00	744.25	55.26	.00		
	SUBSIS.	.00	.00	.00	.00	.00	.00	.00			.00	21.89	120.89	623.36

SEX: M

15609

Date 11/10/14

I, LUCY R. CABALLERO PAYROLL ADMINISTRATOR do hereby state:
(Name of signatory party) (Title)

(1) That I pay or supervise the payment of the persons employed by FOREMOST PAVING on
the MISSION INLET ARCH; that during the payroll period commencing on the 26 day of October 2014
(Building or work)

and ending the 1 day of November 2014 all persons employed on said project have been paid the full
weekly wages earned, that no rebates have been or will be made either directly or indirectly to or on behalf of said
FOREMOST PAVING from the full weekly wages earned by any person and that no deductions have

(Contractor or subcontractor)
been made either directly or indirectly from the full wages earned by any person, other than permissible deductions as defined
in Regulations, Part 5 (29 CFR Subtitle A), issued by the Secretary of Labor under the Copeland Act, as amended (48 Stat. 948;
63 Stat. 108; 72 Stat. 967; 76 Stat. 357; 40 U.S.C. 27 6c), and described below:

(2) That any payrolls otherwise under this contract required to be submitted for the above period are correct and complete;
that the wage rates for laborers or mechanics contained therein are not less than the applicable wage rates contained in any wage
determination incorporated into the contract; that the classifications set forth therein for each laborer or mechanic conform with
the work he performed.

(3) That any apprentices employed in the above period are duly registered in a bona fide apprenticeship program registered
with a State apprenticeship agency recognized by the Bureau of Apprenticeship and Training, United States Department of Labor
or if no such recognized agency exists in a State, are registered with the Bureau of Apprenticeship and Training, United States
Department of Labor

(4) That:

(a) WHERE FRINGE BENEFITS ARE PAID TO APPROVED PLANS, FUNDS, OR PROGRAMS

[] In addition to the basic hourly wage rates paid to each laborer or mechanic listed in the above referenced
payroll, payments of fringe benefits as listed in the contract have been or will be made to appropriate programs
for the benefit of such employees, except as noted in Section 4(c) below.

(b) WHERE FRINGE BENEFITS ARE PAID IN CASH

[] Each laborer or mechanic listed in the above referenced payroll has been paid as indicated on the payroll, an
amount not less than the sum of the applicable basic hourly wage rate plus the amount of the required fringe
benefits as listed in the contract, except as noted in section 4(c) below.

(c) EXCEPTIONS

EXCEPTION (CRAFT)	EXPLANATION

REMARKS

NAME AND TITLE | SIGNATURE
LUCY R. CABALLERO | Lucy R. Caballero
PAYROLL ADMINISTRATOR

THE WILLFUL FALSIFICATION OF ANY OF THE ABOVE STATEMENTS MAY SUBJECT THE CONTRACTOR OR SUBCONTRACTOR TO CIVIL OR CRIMINAL
PROSECUTION. SEE SECTION 1001 OF TITLE 18 AND SECTION 251 OF TITLE 31 OF THE UNITED STATES CODE.

FOREMOST PAVING
 POST OFFICE BOX 29
 WESLACO

CONTRACTOR _____ CONTRACT NO _____
 OR SUBCONTRACTOR _____
 , TX 78599

PROJECT: 15609 MISSION INLET ARCH
 AND LOCATION: STRUCTURE
 WAGE DECISION: 000000000000

PAYROLL NO _____ FOR WEEK ENDING 11/01/14

GROSS - D E D U C T I O N S --

EMPLOYEE NAME, ADDRESS, SOCIAL SECURITY NUMBER AND WORK CLASSIFICATION	SUN 10/26	MON 10/27	TUE 10/28	WED 10/29	THU 10/30	FRI 10/31	SAT 11/01	TOTAL HOURS	GROSS - D E D U C T I O N S --				CHECK NO
									EARNED THIS JOB/ HOURS	FED WH FICA STATE	SDI LTX. OTHER	TOTAL DED- UCTIONS	

SSN: 1224 # DEPS: 5 Work Class: 1172 - 1172														
ALEJANDRO . CHAVEZ	OT .00	.00	.00	.00	1.00	.00	.00	1.00						
	ST .00	10.00	10.00	10.50	9.50	.00	.00	40.00	415.00	.00	.00			129044
	RATE .000	10.000	10.000	10.000	10.000	.000	.000	41.00	415.00	31.75	.00			
	SUBSIS. .00	.00	.00	.00	.00	.00	.00			.00	.00	31.75	383.25	

SEX: M

SSN: 3489 # DEPS: 2 Work Class: 1172 - 1172														
FEDERICO R. GARZA	OT .00	.00	.00	.00	.50	10.00	.00	10.50						
	ST .00	9.50	10.00	10.50	10.00	.00	.00	40.00	557.50	45.62	.00			129050
	RATE .000	10.000	10.000	10.000	10.000	10.000	.000	50.50	557.50	42.65	.00			
	SUBSIS. .00	.00	.00	.00	.00	.00	.00			.00	.00	88.27	469.23	

SEX: M

SSN: 1317 # DEPS: 0 Work Class: 1124 - 1124														
LUIS H. GUTIERREZ	OT .00	.00	.00	.00	5.50	11.00	.00	16.50						
	ST .00	11.00	11.50	11.50	6.00	.00	.00	40.00	822.34	120.08	.00			129045
	RATE .000	12.700	12.700	12.700	12.700	12.700	.000	56.50	822.33	61.37	.00			
	SUBSIS. .00	.00	.00	.00	.00	.00	.00			.00	24.43	205.88	616.45	

SEX: M

SSN: 7940 # DEPS: 2 Work Class: 1175 - 1175														
ELEAZAR . RANGEL	OT .00	.00	.00	.00	1.50	10.00	.00	11.50						
	ST .00	10.50	10.00	10.50	9.00	.00	.00	40.00	744.25	43.74	.00			129047
	RATE .000	13.000	13.000	13.000	13.000	13.000	.000	51.50	744.25	55.26	.00			
	SUBSIS. .00	.00	.00	.00	.00	.00	.00			.00	21.89	120.89	623.36	

SEX: M

15-609

Date 11/17/14

I, LUCY R. CABALLERO PAYROLL ADMINISTRATOR do hereby state:
(Name of signatory party) (Title)

(1) That I pay or supervise the payment of the persons employed by FOREMOST PAVING on
the MISSION INLET ARCH; that during the payroll period commencing on the 2 day of November 2014
(Building or work)
and ending the 8 day of November 2014 all persons employed on said project have been paid the full
weekly wages earned, that no rebates have been or will be made either directly or indirectly to or on behalf of said
FOREMOST PAVING
(Contractor or subcontractor) from the full weekly wages earned by any person and that no deductions have
been made either directly or indirectly from the full wages earned by any person, other than permissible deductions as defined
in Regulations, Part 5 (29 CFR Subtitle A), issued by the Secretary of Labor under the Copeland Act, as amended (48 Stat. 948;
63 Stat. 108; 72 Stat. 967; 76 Stat. 357; 40 U.S.C. 27 6c), and described below:

(2) That any payrolls otherwise under this contract required to be submitted for the above period are correct and complete:
that the wage rates for laborers or mechanics contained therein are not less than the applicable wage rates contained in any wage
determination incorporated into the contract; that the classifications set forth therein for each laborer or mechanic conform with
the work he performed.

(3) That any apprentices employed in the above period are duly registered in a bona fide apprenticeship program registered
with a State apprenticeship agency recognized by the Bureau of Apprenticeship and Training, United States Department of Labor
or if no such recognized agency exists in a State, are registered with the Bureau of Apprenticeship and Training, United States
Department of Labor

(4) That:

(a) WHERE FRINGE BENEFITS ARE PAID TO APPROVED PLANS, FUNDS, OR PROGRAMS

In addition to the basic hourly wage rates paid to each laborer or mechanic listed in the above referenced
payroll, payments of fringe benefits as listed in the contract have been or will be made to appropriate programs
for the benefit of such employees, except as noted in Section 4(c) below.

(b) WHERE FRINGE BENEFITS ARE PAID IN CASH

Each laborer or mechanic listed in the above referenced payroll has been paid as indicated on the payroll, an
amount not less than the sum of the applicable basic hourly wage rate plus the amount of the required fringe
benefits as listed in the contract, except as noted in section 4(c) below.

(c) EXCEPTIONS

EXCEPTION (CRAFT)	EXPLANATION

REMARKS

NAME AND TITLE

LUCY R. CABALLERO

SIGNATURE

, PAYROLL ADMINISTRATOR

Lucy R. Caballero

THE WILLFUL FALSIFICATION OF ANY OF THE ABOVE STATEMENTS MAY SUBJECT THE CONTRACTOR OR SUBCONTRACTOR TO CIVIL OR CRIMINAL
PROSECUTION. SEE SECTION 1001 OF TITLE 18 AND SECTION 251 OF TITLE 31 OF THE UNITED STATES CODE.

FOREMOST PAVING
POST OFFICE BOX 29
WESLACO

CONTRACTOR _____ CONTRACT NO _____
OR SUBCONTRACTOR _____
, TX 78599

PROJECT: 15609 MISSION INLET ARCH
AND LOCATION: STRUCTURE
WAGE DECISION: 000000000000

PAYROLL NO _____ FOR WEEK ENDING 11/08/14

GROSS - D E D U C T I O N S --

EMPLOYEE NAME, ADDRESS, SOCIAL SECURITY NUMBER AND WORK CLASSIFICATION	SSN	SUN 11/02	MON 11/03	TUE 11/04	WED 11/05	THU 11/06	FRI 11/07	SAT 11/08	TOTAL HOURS	GROSS - D E D U C T I O N S --				CHECK NO NET WAGES
										EARNED THIS JOB/ STATE	FED WH FICA	SDI LTX. OTHER	TOTAL DED- UCTIONS	

ALEJANDRO . CHAVEZ	SSN: 1224 # DEPS: 5 Work Class: 1172 - 1172	OT .00	.00	.00	.00	.00	.00	.00	39.50	395.00	.00	.00	129327
	ST .00	10.50	10.00	10.00	9.00	.00	.00	.00	39.50	395.00	30.22	.00	
	RATE .000	10.000	10.000	10.000	10.000	.000	.000	.000					
	SUBSIS. .00	.00	.00	.00	.00	.00	.00	.00			.00	.00	30.22 364.78

SEX: M

JUAN R. GARCIA	SSN: 8128 # DEPS: 0 Work Class: 1175 - 1175	OT .00	.00	.00	.00	.00	.00	.00	36.50	438.00	26.10	.00	129129
	ST .00	8.50	9.00	10.00	9.00	.00	.00	.00	36.50	462.00	33.81	.00	
	RATE .000	12.000	12.000	12.000	12.000	.000	.000	.000					
	SUBSIS. .00	.00	.00	.00	.00	.00	.00	.00			.00	50.36	110.27 351.73

SEX: M

LUIS H. GUTIERREZ	SSN: 1317 # DEPS: 0 Work Class: 1124 - 1124	OT .00	.00	.00	.00	4.50	2.00	.00	6.50				
	ST .00	12.00	10.50	11.50	6.00	.00	.00	.00	40.00	631.83	86.56	.00	129328
	RATE .000	12.700	12.700	12.700	12.700	12.700	.000	.000	46.50	631.83	46.80	.00	
	SUBSIS. .00	.00	.00	.00	.00	.00	.00	.00			.00	24.43	157.79 474.04

SEX: M

ELEAZAR . RANGEL	SSN: 7940 # DEPS: 2 Work Class: 1175 - 1175	OT .00	.00	.00	.00	4.50	2.00	.00	6.50				
	ST .00	12.00	10.50	11.50	6.00	.00	.00	.00	40.00	646.75	31.04	.00	129330
	RATE .000	13.000	13.000	13.000	13.000	13.000	.000	.000	46.50	646.75	47.80	.00	
	SUBSIS. .00	.00	.00	.00	.00	.00	.00	.00			.00	21.89	100.73 546.02

SEX: M

JOSE L. SIERRA	SSN: 7604 # DEPS: 4 Work Class: 1172 - 1172	OT .00	.00	.00	.00	.00	.00	.00	9.00	103.77	.00	.00	129135
	ST .00	.00	.00	.00	9.00	.00	.00	.00	9.00	449.67	32.87	.00	
	RATE .000	.000	.000	.000	11.530	.000	.000	.000	9.00	449.67	32.87	.00	
	SUBSIS. .00	.00	.00	.00	.00	.00	.00	.00			.00	20.00	52.87 396.80

SEX: M

15-609

Date 11/21/14

I, LUCY R. CABALLERO PAYROLL ADMINISTRATOR do hereby state:
(Name of signatory party) (Title)

(1) That I pay or supervise the payment of the persons employed by FOREMOST PAVING on
the MISSION INLET ARCH; that during the payroll period commencing on the 9 day of November 2014
(Building or work)

and ending the 15 day of November 2014 all persons employed on said project have been paid the full
weekly wages earned, that no rebates have been or will be made either directly or indirectly to or on behalf of said
FOREMOST PAVING from the full weekly wages earned by any person and that no deductions have
(Contractor or subcontractor)

been made either directly or indirectly from the full wages earned by any person, other than permissible deductions as defined
in Regulations, Part 5 (29 CFR Subtitle A), issued by the Secretary of Labor under the Copeland Act, as amended (48 Stat. 948;
63 Stat. 108; 72 Stat. 967; 76 Stat. 357; 40 U.S.C. 27 6c), and described below:

(2) That any payrolls otherwise under this contract required to be submitted for the above period are correct and complete;
that the wage rates for laborers or mechanics contained therein are not less than the applicable wage rates contained in any wage
determination incorporated into the contract; that the classifications set forth therein for each laborer or mechanic conform with
the work he performed.

(3) That any apprentices employed in the above period are duly registered in a bona fide apprenticeship program registered
with a State apprenticeship agency recognized by the Bureau of Apprenticeship and Training, United States Department of Labor
or if no such recognized agency exists in a State, are registered with the Bureau of Apprenticeship and Training, United States
Department of Labor

(4) That:

(a) WHERE FRINGE BENEFITS ARE PAID TO APPROVED PLANS, FUNDS, OR PROGRAMS

In addition to the basic hourly wage rates paid to each laborer or mechanic listed in the above referenced
payroll, payments of fringe benefits as listed in the contract have been or will be made to appropriate programs
for the benefit of such employees, except as noted in Section 4(c) below.

(b) WHERE FRINGE BENEFITS ARE PAID IN CASH

Each laborer or mechanic listed in the above referenced payroll has been paid as indicated on the payroll, an
amount not less than the sum of the applicable basic hourly wage rate plus the amount of the required fringe
benefits as listed in the contract, except as noted in section 4(c) below.

(c) EXCEPTIONS

EXCEPTION (CRAFT)	EXPLANATION

REMARKS

NAME AND TITLE

LUCY R. CABALLERO

SIGNATURE

, PAYROLL ADMINISTRATOR

Lucy R. Caballero

THE WILLFUL FALSIFICATION OF ANY OF THE ABOVE STATEMENTS MAY SUBJECT THE CONTRACTOR OR SUBCONTRACTOR TO CIVIL OR CRIMINAL
PROSECUTION. SEE SECTION 1001 OF TITLE 18 AND SECTION 251 OF TITLE 31 OF THE UNITED STATES CODE.

FOREMOST PAVING
 POST OFFICE BOX 29
 WESLACO

CONTRACTOR _____ CONTRACT NO _____
 OR SUBCONTRACTOR _____
 , TX 78599

PROJECT: 15609 MISSION INLET ARCH
 AND LOCATION: STRUCTURE
 WAGE DECISION: 000000000000

PAYROLL NO _____ FOR WEEK ENDING 11/15/14

GROSS - D E D U C T I O N S --

EMPLOYEE NAME, ADDRESS, SOCIAL SECURITY NUMBER AND WORK CLASSIFICATION	SUN 11/09	MON 11/10	TUE 11/11	WED 11/12	THU 11/13	FRI 11/14	SAT 11/15	TOTAL HOURS	GROSS - D E D U C T I O N S --				CHECK NO NET WAGES
									EARNED THIS JOB/ HOURS	FED WH FICA STATE	SDI LTX. OTHER	TOTAL DED- UCTIONS	

SSN: 1224 # DEPS: 5 Work Class: 1172 - 1172

ALEJANDRO . CHAVEZ

OT	.00	.00	.00	.00	.00	.00	.00						
ST	.00	10.00	5.50	.00	.00	.00	.00	15.50	155.00	10.44	.00		129596
RATE	.000	10.000	10.000	.000	.000	.000	.000	15.50	527.50	40.36	.00		
SUBSIS.	.00	.00	.00	.00	.00	.00	.00			.00	.00	50.80	476.70

SEX: M

SSN: 8128 # DEPS: 0 Work Class: 1175 - 1175

JUAN R. GARCIA

OT	.00	.00	.00	.00	.00	.00	.00						
ST	.00	10.00	.00	.00	.00	.00	.00	10.00	120.00	46.33	.00		129410
RATE	.000	12.000	.000	.000	.000	.000	.000	10.00	633.00	46.90	.00		
SUBSIS.	.00	.00	.00	.00	.00	.00	.00			.00	57.20	150.43	482.57

SEX: M

SSN: 1317 # DEPS: 0 Work Class: 1124 - 1124

LUIS H. GUTIERREZ

OT	.00	.00	.00	.00	.00	.00	.00						
ST	.00	11.50	6.00	.00	.00	.00	.00	17.50	222.25	110.55	.00		129597
RATE	.000	12.700	12.700	.000	.000	.000	.000	17.50	784.23	58.46	.00		
SUBSIS.	.00	.00	.00	.00	.00	.00	.00			.00	24.43	193.44	590.79

SEX: M

SSN: 7940 # DEPS: 2 Work Class: 1175 - 1175

ELEAZAR . RANGEL

OT	.00	.00	.00	.00	.00	.00	.00						
ST	.00	11.50	.00	.00	.00	.00	.00	11.50	149.50	43.74	.00		129599
RATE	.000	13.000	.000	.000	.000	.000	.000	11.50	744.25	55.26	.00		
SUBSIS.	.00	.00	.00	.00	.00	.00	.00			.00	21.89	120.89	623.36

SEX: M

U.S. DEPARTMENT OF LABOR
WAGE AND HOUR AND PUBLIC
CONTRACTS DIVISIONS

STATEMENT OF COMPLIANCE

15-609

Form Approved
Budget Bureau No. 44-R1093

Date 11/26/14

I, LUCY R. CABALLERO PAYROLL ADMINISTRATOR do hereby state:
(Name of signatory party) (Title)

(1) That I pay or supervise the payment of the persons employed by FOREMOST PAVING on
the MISSION INLET ARCH; that during the payroll period commencing on the 16 day of November 2014
(Building or work)

and ending the 22 day of November 2014 all persons employed on said project have been paid the full
weekly wages earned, that no rebates have been or will be made either directly or indirectly to or on behalf of said
FOREMOST PAVING
(Contractor or subcontractor) from the full weekly wages earned by any person and that no deductions have
been made either directly or indirectly from the full wages earned by any person, other than permissible deductions as defined
in Regulations, Part 5 (29 CFR Subtitle A), issued by the Secretary of Labor under the Copeland Act, as amended (48 Stat. 948;
63 Stat. 108; 72 Stat. 967; 76 Stat. 357; 40 U.S.C. 27 6c), and described below:

(2) That any payrolls otherwise under this contract required to be submitted for the above period are correct and complete;
that the wage rates for laborers or mechanics contained therein are not less than the applicable wage rates contained in any wage
determination incorporated into the contract: that the classifications set forth therein for each laborer or mechanic conform with
the work he performed.

(3) That any apprentices employed in the above period are duly registered in a bona fide apprenticeship program registered
with a State apprenticeship agency recognized by the Bureau of Apprenticeship and Training, United States Department of Labor
or if no such recognized agency exists in a State, are registered with the Bureau of Apprenticeship and Training, United States
Department of Labor

(4) That:

(a) WHERE FRINGE BENEFITS ARE PAID TO APPROVED PLANS, FUNDS, OR PROGRAMS

In addition to the basic hourly wage rates paid to each laborer or mechanic listed in the above referenced
payroll, payments of fringe benefits as listed in the contract have been or will be made to appropriate programs
for the benefit of such employees, except as noted in Section 4(c) below.

(b) WHERE FRINGE BENEFITS ARE PAID IN CASH

Each laborer or mechanic listed in the above referenced payroll has been paid as indicated on the payroll, an
amount not less than the sum of the applicable basic hourly wage rate plus the amount of the required fringe
benefits as listed in the contract, except as noted in section 4(c) below.

(c) EXCEPTIONS

EXCEPTION (CRAFT)	EXPLANATION

REMARKS

NAME AND TITLE: LUCY R. CABALLERO
SIGNATURE: Lucy R. Caballero
TITLE: PAYROLL ADMINISTRATOR

THE WILLFUL FALSIFICATION OF ANY OF THE ABOVE STATEMENTS MAY SUBJECT THE CONTRACTOR OR SUBCONTRACTOR TO CIVIL OR CRIMINAL PROSECUTION. SEE SECTION 1001 OF TITLE 18 AND SECTION 251 OF TITLE 31 OF THE UNITED STATES CODE.

FOREMOST PAVING
POST OFFICE BOX 29
WESLACO

CONTRACTOR _____ CONTRACT NO _____
OR SUBCONTRACTOR _____
, TX 78599

PROJECT: 15609 MISSION INLET ARCH
AND LOCATION: STRUCTURE
WAGE DECISION: 000000000000

PAYROLL NO _____ FOR WEEK ENDING 11/22/14

EMPLOYEE NAME, ADDRESS, SOCIAL SECURITY NUMBER AND WORK CLASSIFICATION	SUN 11/16	MON 11/17	TUE 11/18	WED 11/19	THU 11/20	FRI 11/21	SAT 11/22	TOTAL HOURS	GROSS - D E D U C T I O N S --				CHECK NO NET WAGES
									EARNED THIS JOB/ STATE	FED WH FICA	SDI LTX. OTHER	TOTAL DED- UCTIONS	

SSN: 1224 # DEPS: 5	Work Class: 1172 - 1172												
ALEJANDRO . CHAVEZ	OT .00	.00	.00	.00	.00	1.00	.00	1.00					
	ST .00	.00	.00	.00	.00	.00	.00		15.00	11.94	.00		129876
	RATE .000	.000	.000	.000	.000	10.000	.000	1.00	542.50	41.51	.00		
	SUBSIS. .00	.00	.00	.00	.00	.00	.00			.00	.00	53.45	489.05

SEX: M

SSN: 8250 # DEPS: 1	Work Class: 1346 - 1346												
SERGIO . GUAJARDO	OT .00	.00	.00	.00	.00	1.00	.00	1.00					
	ST .00	.00	.00	.00	.00	.00	.00		19.50	75.89	.00		129724
	RATE .000	.000	.000	.000	.000	13.000	.000	1.00	705.25	52.28	.00		
	SUBSIS. .00	.00	.00	.00	.00	.00	.00			.00	31.19	159.36	545.89

SEX: M

SSN: 1317 # DEPS: 0	Work Class: 1124 - 1124												
LUIS H. GUTIERREZ	OT .00	.00	.00	.00	.00	1.00	.00	1.00					
	ST .00	.00	.00	.00	.00	.00	.00		19.06	115.32	.00		129877
	RATE .000	.000	.000	.000	.000	12.700	.000	1.00	803.28	59.92	.00		
	SUBSIS. .00	.00	.00	.00	.00	.00	.00			.00	24.43	199.67	603.61

SEX: M

SSN: 7940 # DEPS: 2	Work Class: 1175 - 1175												
ELEAZAR . RANGEL	OT .00	.00	.00	.00	.00	1.00	.00	1.00					
	ST .00	.00	.00	.00	.00	.00	.00		19.50	37.89	.00		129879
	RATE .000	.000	.000	.000	.000	13.000	.000	1.00	705.25	52.28	.00		
	SUBSIS. .00	.00	.00	.00	.00	.00	.00			.00	21.89	112.06	593.19

SEX: M

15609

Date 12/04/14

I, LUCY R. CABALLERO PAYROLL ADMINISTRATOR do hereby state:
(Name of signatory party) (Title)

(1) That I pay or supervise the payment of the persons employed by FOREMOST PAVING on
the MISSION INLET ARCH; that during the payroll period commencing on the 23 day of November 2014
(Building or work)

and ending the 29 day of November 2014 all persons employed on said project have been paid the full
weekly wages earned, that no rebates have been or will be made either directly or indirectly to or on behalf of said
FOREMOST PAVING from the full weekly wages earned by any person and that no deductions have
(Contractor or subcontractor)

been made either directly or indirectly from the full wages earned by any person, other than permissible deductions as defined
in Regulations, Part 5 (29 CFR Subtitle A), issued by the Secretary of Labor under the Copeland Act, as amended (48 Stat. 948;
63 Stat. 108; 72 Stat. 967; 76 Stat. 357; 40 U.S.C. 27 6c), and described below:

(2) That any payrolls otherwise under this contract required to be submitted for the above period are correct and complete;
that the wage rates for laborers or mechanics contained therein are not less than the applicable wage rates contained in any wage
determination incorporated into the contract: that the classifications set forth therein for each laborer or mechanic conform with
the work he performed.

(3) That any apprentices employed in the above period are duly registered in a bona fide apprenticeship program registered
with a State apprenticeship agency recognized by the Bureau of Apprenticeship and Training, United States Department of Labor
or if no such recognized agency exists in a State, are registered with the Bureau of Apprenticeship and Training, United States
Department of Labor

(4) That:

(a) WHERE FRINGE BENEFITS ARE PAID TO APPROVED PLANS, FUNDS, OR PROGRAMS

In addition to the basic hourly wage rates paid to each laborer or mechanic listed in the above referenced
payroll, payments of fringe benefits as listed in the contract have been or will be made to appropriate programs
for the benefit of such employees, except as noted in Section 4(c) below.

(b) WHERE FRINGE BENEFITS ARE PAID IN CASH

Each laborer or mechanic listed in the above referenced payroll has been paid as indicated on the payroll, an
amount not less than the sum of the applicable basic hourly wage rate plus the amount of the required fringe
benefits as listed in the contract, except as noted in section 4(c) below.

(c) EXCEPTIONS

EXCEPTION (CRAFT)	EXPLANATION

REMARKS

NO WORK PERFORMED

NAME AND TITLE
LUCY R. CABALLERO

SIGNATURE
, PAYROLL ADMINISTRATOR

Lucy R. Caballero

THE WILLFUL FALSIFICATION OF ANY OF THE ABOVE STATEMENTS MAY SUBJECT THE CONTRACTOR OR SUBCONTRACTOR TO CIVIL OR CRIMINAL
PROSECUTION. SEE SECTION 1001 OF TITLE 18 AND SECTION 251 OF TITLE 31 OF THE UNITED STATES CODE.

Test Report Table

Material	Test	Description	Required	Remarks	CONTRACTOR: Rojoas Construction & Paving, LLC				
					Pay Req 1 CSI#	Pay Req 2 CSI#	Pay Req 3 CSI#	Pay Req - 4 CSI#	Pay Req 5 CSI#
Soils	ASTM D698	Laboratory Compaction Characteristics of Soil Using Standard Effort							
	ASTM D1140	Amount of Material in Soils Finer than No. 200 (75-µm) Sieve							
	ASTM D4318	Liquid Limit, Plastic Limit, and Plasticity Index of Soils							
	ASTM D558	Moisture-Density (Unit Weight) Relations of Soil-Cement Mixtures							
	ASTM D6938	In-Place Density and Water Content of Soil and Soil-Aggregate by Nuclear Methods (Shallow Depth)							
Subgrade	Tex-101-E Part III	Pulverization							
	Tex-113-E	Laboratory Compaction Characteristics & Moisture Density Relationship of Base Materials							
	Tex-114-E	Laboratory Compaction Characteristics & Moisture Density Relationship of Sub-Grade, Embankment Soils, and Backfill Material							
Flex Base	Tex-101-E	Surveying and Sampling Soils for Highways							
	Tex-103-E	Determining Moisture Content in Soil Materials							
	Tex-104-E	Determining Liquid Limit of Soils							
	Tex-105-E	Determining Plastic Limit of Soils							
	Tex-106-E	Calculating the Plasticity Index of Soils							
	Tex-107-E	Determining the Bar Linear Shrinkage of Soils							
	Tex-110-E	Particle Size Analysis of Soils							
	Tex-115-E	Field Method for Determining In-Place Density of Soils and Base Materials							
	Tex-116-E	Ball Mill Method for Determining the Disintegration of Flexible Base Material							
	Tex-117-E	Triaxial Compression for Disturbed Soils and Base Materials							
EN-1	IAW ASTM 4609								
	TexDOT 121 E								
	ASTM D 4548								
	ASTM D 1587								
Hot Mix	Tex-207-F	Determining Density of Compacted Bituminous Mixtures							
	Tex-208-F	Test for Stabilometer Value of Bituminous Mixtures							
	Tex-210-F	Determining Asphalt Content of Bituminous Mixtures by Extraction							
	Tex-228-F	Determining Asphalt Content of Bituminous Mixtures by the Nuclear Method							
	Tex-229-F	Combined HMAAC Cold Belt Sampling and Testing Procedure							
	Tex-236-F	Determining Asphalt Content from Asphalt Paving Mixtures By the Ignition Method							
	Tex-207-E	Determining Density of Compacted Bituminous Mixtures							
	Tex-212-E	Determining Moisture Content of Bituminous Mixtures							
	Tex-213-E	Determining Hydrocarbon - Volatile Content of Bituminous Mixtures							
In-Place Density	ASTM G-295078								
	AASHTO T-188								
Lime	Tex-600-J	Lime Testing Procedure (W/Note: testing if less than 50 Tons from a Pre-Approved Source)							
		Three Edge Bearing Test							
Concrete		Compressive Strength Test							
			36 Samples / Passed						HCDD1-14-025-09-09

Engineer's Signature: _____

Rain JH, P.E.

Exhibit E-G

LABORATORY TEST REPORT

Compressive Strength Test



Raba Kistner Consultants Inc.
800 East Hackberry
McAllen, Texas 78501
(956) 682-5332 • FAX(956) 682-5487
www.rkci.com
TBPE Firm F-3257

ATTN.: MR. RAMIRO GUTIERREZ, P.E., PRESIDENT
TO: R. GUTIERREZ ENGINEERING CORPORATION
130 E. PARK AVENUE
PHARR, TEXAS 78577

PROJECT NO.: AMD14-089-00
CAST DATE: 10/29/2014
ASSIGNMENT NO.: M14-013601
REPORT VERSION: A
TECHNICIAN: ELOY ARREDONDO JR

PROJECT: Hidalgo County DD #1 Mission Inlet Arch Culvert Aluminum Liner Plate Re-Line, McAllen, Hidalgo County, Tx.

SAMPLE LOCATION: Non Shrink Grout: Between Liner Plates & Existing Arch Structure Section Located Near STA.: 3 + 21, South Side

SET INDEX:	Set 1 of 1								
SUPPLIER:	Subcontractor	BATCH TIME:	7:45 a.m.	AIR CONTENT (%):	NA				
TRUCK NO:	NA	SAMPLE TIME:	8:15 a.m.	UNIT WEIGHT (pcf):	NA				
TICKET NO:	Field Batch	SAMPLE TEMP. (°F):	72	FIELD CURED (day):	1				
SAMPLED AT (cu yds):	NP	AMBIENT TEMP. (°F):	68	SAMPLE TYPE:	Mortar Cube				
DESIGN STR.(psi):	4,000	SLUMP (in.):	NA	SAMPLE SIZE(in.):	2 x 2				
PRODUCT NO.:	Euclid Non-Shrink Grout								

SPECIMEN NUMBER	DATE OF TEST	AGE (days)	LOAD (lbs)	DIAMETER (in)	AREA (in. ²)	STRENGTH (psi)	PERCENT OF DESIGN	FRACTURE TYPE	TESTED BY
1	11/05/2014	7	31,690	NA	4.00	7,920	198	Type 3	A. Hernandez
2	11/05/2014	7	31,470	NA	4.00	7,870	197	Type 3	A. Hernandez
3	11/05/2014	7	31,025	NA	4.00	7,760	194	Type 3	A. Hernandez
4	11/26/2014	28							
5	11/26/2014	28							
6	11/26/2014	28							

NOTE: Some information on this test report provided by others. Testing and reporting was conducted in general accordance with the following applicable A.S.T.M. references: C31, C39, C109, C138, C143, C172, C173, C231, C495, C1019, C1064, and C1231.

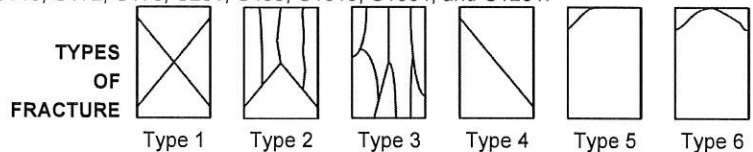

REMARKS: Stan w/Foremost Paving, Inc., was verbally notified of field test results. ND-Not Determined; NP-Not Provided; NA-Not Applicable.

NOTICE: Raba Kistner Consultants, Inc. considers the data and information contained in this report to be proprietary. This information is intended only for the use of the recipient(s) named herein. Test results presented herein relate only to those items tested. This document and any information contained herein shall not be disclosed and shall not be duplicated or used in whole or in part for any purpose other than to validate test results without written approval from Raba Kistner Consultants, Inc.

COPIES TO: Above (1)
jaime@rgec.net(2)
diego@fpitex.com(3)
rgutierrez@rgutierrezengineering.com(1)
jimmie@fpitex.com(1)
diego@fpitex.com(1)

RABA KISTNER CONSULTANTS, INC.

Carlos Ceballos Jr.

BY: _____
11/07/2014



Updated By: MMR 11/7/2014 8:49:17AM

Austin • Brownsville • Dallas • El Paso • Houston • McAllen • Mexico • New Braunfels • Salt Lake City • San Antonio



LABORATORY TEST REPORT

Compressive Strength Test



Raba Kistner Consultants Inc.
800 East Hackberry
McAllen, Texas 78501
(956) 682-5332 • FAX(956) 682-5487
www.rkci.com
TBPE Firm F-3257

ATTN.: MR. RAMIRO GUTIERREZ, P.E., PRESIDENT
TO: R. GUTIERREZ ENGINEERING CORPORATION
130 E. PARK AVENUE
PHARR, TEXAS 78577

PROJECT NO.: AMD14-089-00
CAST DATE: 10/29/2014
ASSIGNMENT NO.: M14-013601
REPORT VERSION: A
TECHNICIAN: ELOY ARREDONDO JR

PROJECT: Hidalgo County DD #1 Mission Inlet Arch Culvert Aluminum Liner Plate Re-Line, McAllen, Hidalgo County, Tx.

SAMPLE LOCATION: Non Shrink Grout: Between Liner Plates & Existing Arch Structure Section Located Near STA.: 3 + 21, South Side

SET INDEX:	Set 1 of 1								
SUPPLIER:	Subcontractor	BATCH TIME:	7:45 a.m.	AIR CONTENT (%):	NA				
TRUCK NO:	NA	SAMPLE TIME:	8:15 a.m.	UNIT WEIGHT (pcf):	NA				
TICKET NO:	Field Batch	SAMPLE TEMP. (°F):	72	FIELD CURED (day):	1				
SAMPLED AT (cu yds):	NP	AMBIENT TEMP. (°F):	68	SAMPLE TYPE:	Mortar Cube				
DESIGN STR.(psi):	4,000	SLUMP (in.):	NA	SAMPLE SIZE(in.):	2 x 2				
PRODUCT NO.:	Euclid Non-Shrink Grout								

SPECIMEN NUMBER	DATE OF TEST	AGE (days)	LOAD (lbs)	DIAMETER (in)	AREA (in. ²)	STRENGTH (psi)	PERCENT OF DESIGN	FRACTURE TYPE	TESTED BY
1	11/05/2014	7	31,690	NA	4.00	7,920	198	Type 3	A. Hernandez
2	11/05/2014	7	31,470	NA	4.00	7,870	197	Type 3	A. Hernandez
3	11/05/2014	7	31,025	NA	4.00	7,760	194	Type 3	A. Hernandez
4	11/26/2014	28	37,155	NA	4.00	9,290	232	Type 3	A. Hernandez
5	11/26/2014	28	36,460	NA	4.00	9,120	228	Type 3	A. Hernandez
6	11/26/2014	28	35,895	NA	4.00	8,970	224	Type 3	A. Hernandez

NOTE: Some information on this test report provided by others. Testing and reporting was conducted in general accordance with the following applicable A.S.T.M. references: C31, C39, C109, C138, C143, C172, C173, C231, C495, C1019, C1064, and C1231.

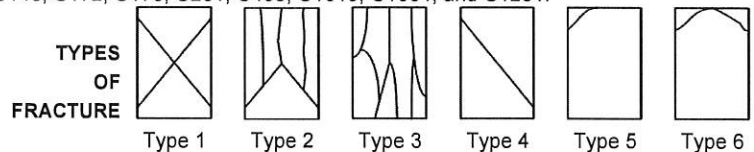

REMARKS: Stan w/Foremost Paving, Inc., was verbally notified of field test results. ND-Not Determined; NP-Not Provided; NA-Not Applicable.

NOTICE: Raba Kistner Consultants, Inc. considers the data and information contained in this report to be proprietary. This information is intended only for the use of the recipient(s) named herein. Test results presented herein relate only to those items tested. This document and any information contained herein shall not be disclosed and shall not be duplicated or used in whole or in part for any purpose other than to validate test results without written approval from Raba Kistner Consultants, Inc.

COPIES TO: Above (1)
jaime@rgec.net(2)
diego@fpitex.com(3)
rgutierrez@rgutierrezengineering.com(1)
jimmie@fpitex.com(1)
diego@fpitex.com(1)

RABA KISTNER CONSULTANTS, INC.



Updated By: MMR 11/26/2014 11:34:35AM

Austin • Brownsville • Dallas • El Paso • Houston • McAllen • Mexico • New Braunfels • Salt Lake City • San Antonio



LABORATORY TEST REPORT

Compressive Strength Test



Raba Kistner Consultants Inc.
800 East Hackberry
McAllen, Texas 78501
(956) 682-5332 • FAX(956) 682-5487
www.rkci.com
TBPE Firm F-3257

ATTN.: MR. RAMIRO GUTIERREZ, P.E., PRESIDENT
TO: R. GUTIERREZ ENGINEERING CORPORATION
130 E. PARK AVENUE
PHARR, TEXAS 78577

PROJECT NO.: AMD14-089-00
CAST DATE: 11/03/2014
ASSIGNMENT NO.: M14-013670
REPORT VERSION: A
TECHNICIAN: ARMANDO RODRIGUEZ JR

PROJECT: Hidalgo County DD #1 Mission Inlet Arch Culvert Aluminum Liner Plate Re-Line, McAllen, Hidalgo County, Tx.

SAMPLE LOCATION: Non-Metallic, Non-Shrink Cementitious Grout for Inlet Arch Culvert Section Near STA.: 300+00

SET INDEX:	Set 1 of 1	BATCH TIME:	3:01 p.m.	AIR CONTENT (%):	ND
SUPPLIER:	CEMEX	SAMPLE TIME:	3:25 p.m.	UNIT WEIGHT (pcf):	ND
TRUCK NO:	10036841	SAMPLE TEMP. (°F):	85	FIELD CURED (day):	1
TICKET NO:	42796871	AMBIENT TEMP. (°F):	81	SAMPLE TYPE:	Mortar Cube
SAMPLED AT (cu yds):	5	SLUMP (in.):	7.00	SAMPLE SIZE(in.):	2 x 2
DESIGN STR.(psi):	2,500				
PRODUCT NO.:	1421915				

SPECIMEN NUMBER	DATE OF TEST	AGE (days)	LOAD (lbs)	DIAMETER (in)	AREA (in. ²)	STRENGTH (psi)	PERCENT OF DESIGN	FRACTURE TYPE	TESTED BY
7	11/10/2014	7	14,415	NA	4.00	3,600	144	Type 3	A. Hernandez
8	11/10/2014	7	14,430	NA	4.00	3,610	144	Type 3	A. Hernandez
9	11/10/2014	7	15,290	NA	4.00	3,820	153	Type 3	A. Hernandez
10	12/01/2014	28							
11	12/01/2014	28							
12	12/01/2014	28							

NOTE: Some information on this test report provided by others. Testing and reporting was conducted in general accordance with the following applicable A.S.T.M. references: C31, C39, C109, C138, C143, C172, C173, C231, C495, C1019, C1064, and C1231.

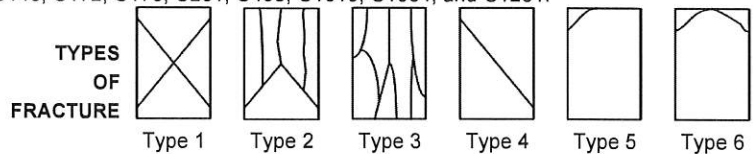

REMARKS: Stanley w/Foremost Paving, Inc., was verbally notified of field test results. ND-Not Determined; NP-Not Provided; NA-Not Applicable.

NOTICE: Raba Kistner Consultants, Inc. considers the data and information contained in this report to be proprietary. This information is intended only for the use of the recipient(s) named herein. Test results presented herein relate only to those items tested. This document and any information contained herein shall not be disclosed and shall not be duplicated or used in whole or in part for any purpose other than to validate test results without written approval from Raba Kistner Consultants, Inc.

COPIES TO: Above (1)
jaime@rgec.net(2)
diego@fpitex.com(3)
rgutierrez@rgutierrezengineering.com(1)
jimmie@fpitex.com(1)
diego@fpitex.com(1)

RABA KISTNER CONSULTANTS, INC.

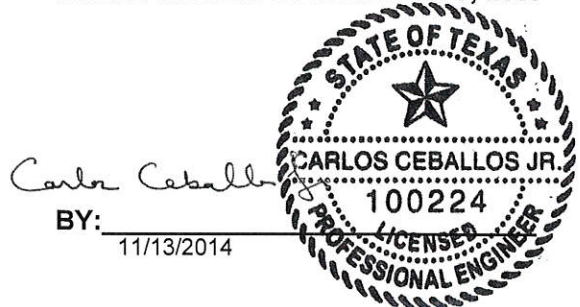

Updated By: CCJ 11/13/2014 4:01:42PM

Austin • Brownsville • Dallas • El Paso • Houston • McAllen • Mexico • New Braunfels • Salt Lake City • San Antonio



LABORATORY TEST REPORT

Compressive Strength Test



Raba Kistner Consultants Inc.
800 East Hackberry
McAllen, Texas 78501
(956) 682-5332 • FAX(956) 682-5487
www.rkci.com
TBPE Firm F-3257

ATTN.: MR. RAMIRO GUTIERREZ, P.E., PRESIDENT
TO: R. GUTIERREZ ENGINEERING CORPORATION
130 E. PARK AVENUE
PHARR, TEXAS 78577

PROJECT NO.: AMD14-089-00
CAST DATE: 11/03/2014
ASSIGNMENT NO.: M14-013670
REPORT VERSION: A
TECHNICIAN: ARMANDO RODRIGUEZ JR

PROJECT: Hidalgo County DD #1 Mission Inlet Arch Culvert Aluminum Liner Plate Re-Line, McAllen, Hidalgo County, Tx.

SAMPLE LOCATION: Non-Metallic, Non-Shrink Cementitious Grout for Inlet Arch Culvert Section Near STA.: 300+00

SET INDEX:	Set 1 of 1	BATCH TIME:	3:01 p.m.	AIR CONTENT (%):	ND
SUPPLIER:	CEMEX	SAMPLE TIME:	3:25 p.m.	UNIT WEIGHT (pcf):	ND
TRUCK NO:	10036841	SAMPLE TEMP. (°F):	85	FIELD CURED (day):	1
TICKET NO:	42796871	AMBIENT TEMP. (°F):	81	SAMPLE TYPE:	Mortar Cube
SAMPLED AT (cu yds):	5	SLUMP (in.):	7.00	SAMPLE SIZE (in.):	2 x 2
DESIGN STR. (psi):	2,500				
PRODUCT NO.:	1421915				

SPECIMEN NUMBER	DATE OF TEST	AGE (days)	LOAD (lbs)	DIAMETER (in)	AREA (in. ²)	STRENGTH (psi)	PERCENT OF DESIGN	FRACTURE TYPE	TESTED BY
7	11/10/2014	7	14,415	NA	4.00	3,600	144	Type 3	A. Hernandez
8	11/10/2014	7	14,430	NA	4.00	3,610	144	Type 3	A. Hernandez
9	11/10/2014	7	15,290	NA	4.00	3,820	153	Type 3	A. Hernandez
10	12/01/2014	28	19,975	NA	4.00	4,990	200	Type 3	A. Hernandez
11	12/01/2014	28	20,230	NA	4.00	5,060	202	Type 3	A. Hernandez
12	12/01/2014	28	20,540	NA	4.00	5,140	206	Type 3	A. Hernandez

NOTE: Some information on this test report provided by others. Testing and reporting was conducted in general accordance with the following applicable A.S.T.M. references: C31, C39, C109, C138, C143, C172, C173, C231, C495, C1019, C1064, and C1231.

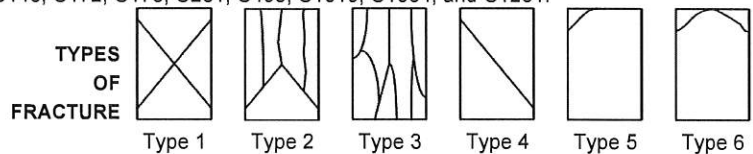

REMARKS: Stanley w/Foremost Paving, Inc., was verbally notified of field test results. ND-Not Determined; NP-Not Provided; NA-Not Applicable.

NOTICE: Raba Kistner Consultants, Inc. considers the data and information contained in this report to be proprietary. This information is intended only for the use of the recipient(s) named herein. Test results presented herein relate only to those items tested. This document and any information contained herein shall not be disclosed and shall not be duplicated or used in whole or in part for any purpose other than to validate test results without written approval from Raba Kistner Consultants, Inc.

COPIES TO: Above (1)
jaime@rgec.net(2)
diego@fpitex.com(3)
rgutierrez@rgutierrezengineering.com(1)
jimmie@fpitex.com(1)
diego@fpitex.com(1)

RABA KISTNER CONSULTANTS, INC.



Updated By: MMR 12/1/2014 2:17:09PM

Austin • Brownsville • Dallas • El Paso • Houston • McAllen • Mexico • New Braunfels • Salt Lake City • San Antonio



LABORATORY TEST REPORT

Compressive Strength Test



Raba Kistner Consultants Inc.
800 East Hackberry
McAllen, Texas 78501
(956) 682-5332 • FAX(956) 682-5487
www.rkci.com
TBPE Firm F-3257

ATTN.: MR. RAMIRO GUTIERREZ, P.E., PRESIDENT
TO: R. GUTIERREZ ENGINEERING CORPORATION
130 E. PARK AVENUE
PHARR, TEXAS 78577

PROJECT NO.: AMD14-089-00
CAST DATE: 11/05/2014
ASSIGNMENT NO.: M14-013713
REPORT VERSION: A
TECHNICIAN: VICTOR SALINAS III

PROJECT: Hidalgo County DD #1 Mission Inlet Arch Culvert Aluminum Liner Plate Re-Line, McAllen, Hidalgo County, Tx.

SAMPLE LOCATION: Grout for Inlet Arch Culvert Section From STA. 300+00 to STA. 330+00, From About 5' to 7' Above the Floor Elevation

SET INDEX:	Set 1 of 1	BATCH TIME:	8:08 a.m.	AIR CONTENT (%):	NA
SUPPLIER:	CEMEX	SAMPLE TIME:	9:00 a.m.	UNIT WEIGHT (pcf):	NA
TRUCK NO:	10035593	SAMPLE TEMP. (°F):	84	FIELD CURED (day):	1
TICKET NO:	42799903	AMBIENT TEMP. (°F):	71	SAMPLE TYPE:	Grout Cube
SAMPLED AT (cu yds):	5.5	SLUMP (in.):	NA	SAMPLE SIZE(in.):	2 x 2
DESIGN STR.(psi):	2,500				
PRODUCT NO.:	1421915				

SPECIMEN NUMBER	DATE OF TEST	AGE (days)	LOAD (lbs)	DIAMETER (in)	AREA (in. ²)	STRENGTH (psi)	PERCENT OF DESIGN	FRACTURE TYPE	TESTED BY
13	11/12/2014	7	13,250	NA	4.00	3,310	132	Type 3	A. Hernandez
14	11/12/2014	7	13,160	NA	4.00	3,290	132	Type 3	A. Hernandez
15	11/12/2014	7	13,865	NA	4.00	3,470	139	Type 3	A. Hernandez
16	12/03/2014	28							
17	12/03/2014	28							
18	12/03/2014	28							

NOTE: Some information on this test report provided by others. Testing and reporting was conducted in general accordance with the following applicable A.S.T.M. references: C31, C39, C109, C138, C143, C172, C173, C231, C495, C1019, C1064, and C1231.

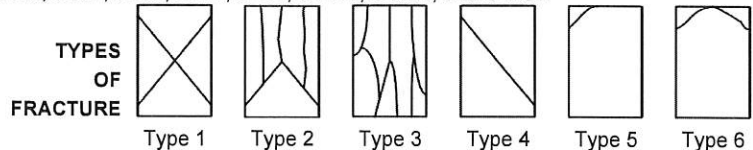

REMARKS: Stanley w/Foremost Paving, Inc., was verbally notified of field test results. ND-Not Determined; NP-Not Provided; NA-Not Applicable.

NOTICE: Raba Kistner Consultants, Inc. considers the data and information contained in this report to be proprietary. This information is intended only for the use of the recipient(s) named herein. Test results presented herein relate only to those items tested. This document and any information contained herein shall not be disclosed and shall not be duplicated or used in whole or in part for any purpose other than to validate test results without written approval from Raba Kistner Consultants, Inc.

COPIES TO: Above (1)
jaime@rgec.net(2)
diego@fpitex.com(3)
rgutierrez@rgutierrezengineering.com(1)
jimmie@fpitex.com(1)
diego@fpitex.com(1)

RABA KISTNER CONSULTANTS, INC.



Updated By: CCJ 11/13/2014 4:07:27PM

Austin • Brownsville • Dallas • El Paso • Houston • McAllen • Mexico • New Braunfels • Salt Lake City • San Antonio



LABORATORY TEST REPORT

Compressive Strength Test



Raba Kistner Consultants Inc.
800 East Hackberry
McAllen, Texas 78501
(956) 682-5332 • FAX(956) 682-5487
www.rkci.com
TBPE Firm F-3257

ATTN.: MR. RAMIRO GUTIERREZ, P.E., PRESIDENT
TO: R. GUTIERREZ ENGINEERING CORPORATION
130 E. PARK AVENUE
PHARR, TEXAS 78577

PROJECT NO.: AMD14-089-00
CAST DATE: 11/05/2014
ASSIGNMENT NO.: M14-013713
REPORT VERSION: A
TECHNICIAN: VICTOR SALINAS III

PROJECT: Hidalgo County DD #1 Mission Inlet Arch Culvert Aluminum Liner Plate Re-Line, McAllen, Hidalgo County, Tx.

SAMPLE LOCATION: Grout for Inlet Arch Culvert Section From STA. 300+00 to STA. 330+00, From About 5' to 7' Above the Floor Elevation

SET INDEX:	Set 1 of 1								
SUPPLIER:	CEMEX	BATCH TIME:	8:08 a.m.	AIR CONTENT (%):	NA				
TRUCK NO:	10035593	SAMPLE TIME:	9:00 a.m.	UNIT WEIGHT (pcf):	NA				
TICKET NO:	42799903	SAMPLE TEMP. (°F):	84	FIELD CURED (day):	1				
SAMPLED AT (cu yds):	5.5	AMBIENT TEMP. (°F):	71	SAMPLE TYPE:	Grout Cube				
DESIGN STR. (psi):	2,500	SLUMP (in.):	NA	SAMPLE SIZE(in.):	2 x 2				
PRODUCT NO.:	1421915								

SPECIMEN NUMBER	DATE OF TEST	AGE (days)	LOAD (lbs)	DIAMETER (in)	AREA (in. ²)	STRENGTH (psi)	PERCENT OF DESIGN	FRACTURE TYPE	TESTED BY
13	11/12/2014	7	13,250	NA	4.00	3,310	132	Type 3	A. Hernandez
14	11/12/2014	7	13,160	NA	4.00	3,290	132	Type 3	A. Hernandez
15	11/12/2014	7	13,865	NA	4.00	3,470	139	Type 3	A. Hernandez
16	12/03/2014	28	14,650	NA	4.00	3,660	146	Type 3	R. Rodriguez
17	12/03/2014	28	17,570	NA	4.00	4,390	176	Type 3	R. Rodriguez
18	12/03/2014	28	15,430	NA	4.00	3,860	154	Type 3	R. Rodriguez

NOTE: Some information on this test report provided by others. Testing and reporting was conducted in general accordance with the following applicable A.S.T.M. references: C31, C39, C109, C138, C143, C172, C173, C231, C495, C1019, C1064, and C1231.

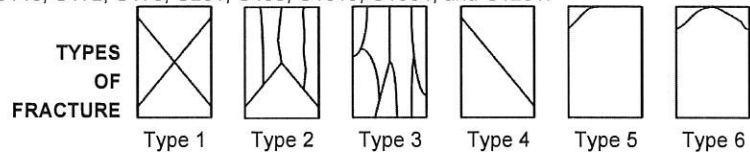

REMARKS: Stanley w/Foremost Paving, Inc., was verbally notified of field test results. ND-Not Determined; NP-Not Provided; NA-Not Applicable.

NOTICE: Raba Kistner Consultants, Inc. considers the data and information contained in this report to be proprietary. This information is intended only for the use of the recipient(s) named herein. Test results presented herein relate only to those items tested. This document and any information contained herein shall not be disclosed and shall not be duplicated or used in whole or in part for any purpose other than to validate test results without written approval from Raba Kistner Consultants, Inc.

COPIES TO: Above (1)
jaime@rgec.net(2)
diego@fpitex.com(3)
rgutierrez@rgutierrezengineering.com(1)
jimmie@fpitex.com(1)
diego@fpitex.com(1)

RABA KISTNER CONSULTANTS, INC.



Updated By: MMR 12/3/2014 3:18:09PM

Austin • Brownsville • Dallas • El Paso • Houston • McAllen • Mexico • New Braunfels • Salt Lake City • San Antonio



LABORATORY TEST REPORT

Compressive Strength Test



Raba Kistner Consultants Inc.
800 East Hackberry
McAllen, Texas 78501
(956) 682-5332 • FAX(956) 682-5487
www.rkci.com
T8PE Firm F-3257

ATTN.: MR. RAMIRO GUTIERREZ, P.E., PRESIDENT
TO: R. GUTIERREZ ENGINEERING CORPORATION
130 E. PARK AVENUE
PHARR, TEXAS 78577

PROJECT NO.: AMD14-089-00
CAST DATE: 11/05/2014
ASSIGNMENT NO.: M14-013714
REPORT VERSION: A
TECHNICIAN: VICTOR SALINAS III

PROJECT: Hidalgo County DD #1 Mission Inlet Arch Culvert Aluminum Liner Plate Re-Line, McAllen, Hidalgo County, Tx.

SAMPLE LOCATION: Grout for Inlet Arch Culvert Section From STA. 300 + 00 to STA. 330 + 00, From About 7' to 9' Above the Floor Elevation

SET INDEX:	Set 1 of 1	BATCH TIME:	12:30 p.m.	AIR CONTENT (%):	NA
SUPPLIER:	CEMEX	SAMPLE TIME:	1:35 p.m.	UNIT WEIGHT (pcf):	NA
TRUCK NO:	10036849	SAMPLE TEMP. (°F):	85	FIELD CURED (day):	1
TICKET NO:	40800480	AMBIENT TEMP. (°F):	74	SAMPLE TYPE:	Mortar Cube
SAMPLED AT (cu yds):	6	SLUMP (in.):	NA	SAMPLE SIZE(in.):	2 x 2
DESIGN STR.(psi):	2,500				
PRODUCT NO.:	1421915				

SPECIMEN NUMBER	DATE OF TEST	AGE (days)	LOAD (lbs)	DIAMETER (in)	AREA (in. ²)	STRENGTH (psi)	PERCENT OF DESIGN	FRACTURE TYPE	TESTED BY
19	11/12/2014	7	12,845	NA	4.00	3,210	128	Type 3	A. Hernandez
20	11/12/2014	7	12,585	NA	4.00	3,150	126	Type 3	A. Hernandez
21	11/12/2014	7	12,050	NA	4.00	3,010	120	Type 3	A. Hernandez
22	12/03/2014	28							
23	12/03/2014	28							
24	12/03/2014	28							

NOTE: Some information on this test report provided by others. Testing and reporting was conducted in general accordance with the following applicable A.S.T.M. references: C31, C39, C109, C138, C143, C172, C173, C231, C495, C1019, C1064, and C1231.

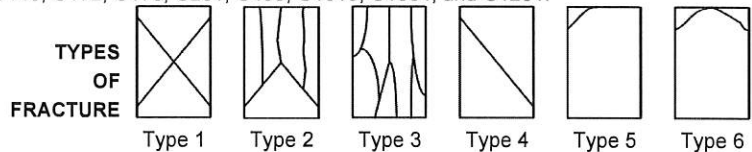

REMARKS: Stanley w/Foremost Paving, Inc., was verbally notified of field test results. ND-Not Determined; NP-Not Provided; NA-Not Applicable.

NOTICE: Raba Kistner Consultants, Inc. considers the data and information contained in this report to be proprietary. This information is intended only for the use of the recipient(s) named herein. Test results presented herein relate only to those items tested. This document and any information contained herein shall not be disclosed and shall not be duplicated or used in whole or in part for any purpose other than to validate test results without written approval from Raba Kistner Consultants, Inc.

COPIES TO: Above (1)
jaime@rgec.net(2)
diego@fpitex.com(3)
rgutierrez@rgutierrezengineering.com(1)
jimmie@fpitex.com(1)
diego@fpitex.com(1)

RABA KISTNER CONSULTANTS, INC.

BY: *Carlos Ceballos Jr.*
11/13/2014



Updated By: CCJ 11/13/2014 4:08:19PM

Austin • Brownsville • Dallas • El Paso • Houston • McAllen • Mexico • New Braunfels • Salt Lake City • San Antonio



LABORATORY TEST REPORT

Compressive Strength Test



Raba Kistner Consultants Inc.
800 East Hackberry
McAllen, Texas 78501
(956) 682-5332 • FAX(956) 682-5487
www.rkci.com
TBPE Firm F-3257

ATTN.: MR. RAMIRO GUTIERREZ, P.E., PRESIDENT
TO: R. GUTIERREZ ENGINEERING CORPORATION
130 E. PARK AVENUE
PHARR, TEXAS 78577

PROJECT NO.: AMD14-089-00
CAST DATE: 11/05/2014
ASSIGNMENT NO.: M14-013714
REPORT VERSION: A
TECHNICIAN: VICTOR SALINAS III

PROJECT: Hidalgo County DD #1 Mission Inlet Arch Culvert Aluminum Liner Plate Re-Line, McAllen, Hidalgo County, Tx.

SAMPLE LOCATION: Grout for Inlet Arch Culvert Section From STA. 300 + 00 to STA. 330 + 00, From About 7' to 9' Above the Floor Elevation

SET INDEX:	Set 1 of 1	BATCH TIME:	12:30 p.m.	AIR CONTENT (%):	NA
SUPPLIER:	CEMEX	SAMPLE TIME:	1:35 p.m.	UNIT WEIGHT (pcf):	NA
TRUCK NO:	10036849	SAMPLE TEMP. (°F):	85	FIELD CURED (day):	1
TICKET NO:	40800480	AMBIENT TEMP. (°F):	74	SAMPLE TYPE:	Mortar Cube
SAMPLED AT (cu yds):	6	SLUMP (in.):	NA	SAMPLE SIZE(in.):	2 x 2
DESIGN STR.(psi):	2,500				
PRODUCT NO.:	1421915				

SPECIMEN NUMBER	DATE OF TEST	AGE (days)	LOAD (lbs)	DIAMETER (in)	AREA (in. ²)	STRENGTH (psi)	PERCENT OF DESIGN	FRACTURE TYPE	TESTED BY
19	11/12/2014	7	12,845	NA	4.00	3,210	128	Type 3	A. Hernandez
20	11/12/2014	7	12,585	NA	4.00	3,150	126	Type 3	A. Hernandez
21	11/12/2014	7	12,050	NA	4.00	3,010	120	Type 3	A. Hernandez
22	12/03/2014	28	16,020	NA	4.00	4,010	160	Type 3	R. Rodriguez
23	12/03/2014	28	15,685	NA	4.00	3,920	157	Type 3	R. Rodriguez
24	12/03/2014	28	16,225	NA	4.00	4,060	162	Type 3	R. Rodriguez

NOTE: Some information on this test report provided by others. Testing and reporting was conducted in general accordance with the following applicable A.S.T.M. references: C31, C39, C109, C138, C143, C172, C173, C231, C495, C1019, C1064, and C1231.

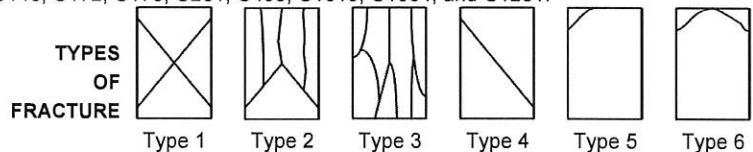

REMARKS: Stanley w/Foremost Paving, Inc., was verbally notified of field test results. ND-Not Determined; NP-Not Provided; NA-Not Applicable.

NOTICE: Raba Kistner Consultants, Inc. considers the data and information contained in this report to be proprietary. This information is intended only for the use of the recipient(s) named herein. Test results presented herein relate only to those items tested. This document and any information contained herein shall not be disclosed and shall not be duplicated or used in whole or in part for any purpose other than to validate test results without written approval from Raba Kistner Consultants, Inc.

COPIES TO: Above (1)
jaime@rgec.net(2)
diego@fpitex.com(3)
rgutierrez@rgutierrezengineering.com(1)
jimmie@fpitex.com(1)
diego@fpitex.com(1)

RABA KISTNER CONSULTANTS, INC.



Updated By: MMR 12/3/2014 3:18:29PM

Austin • Brownsville • Dallas • El Paso • Houston • McAllen • Mexico • New Braunfels • Salt Lake City • San Antonio



LABORATORY TEST REPORT

Compressive Strength Test



Raba Kistner Consultants Inc.
800 East Hackberry
McAllen, Texas 78501
(956) 682-5332 • FAX(956) 682-5487
www.rkci.com
T&PE Firm F-3257

ATTN.: MR. RAMIRO GUTIERREZ, P.E., PRESIDENT
TO: R. GUTIERREZ ENGINEERING CORPORATION
130 E. PARK AVENUE
PHARR, TEXAS 78577

PROJECT NO.: AMD14-089-00
CAST DATE: 11/06/2014
ASSIGNMENT NO.: M14-013727
REPORT VERSION: A
TECHNICIAN: VICTOR SALINAS III

PROJECT: Hidalgo County DD #1 Mission Inlet Arch Culvert Aluminum Liner Plate Re-Line, McAllen, Hidalgo County, Tx.

SAMPLE LOCATION: Grout for Inlet Arch Culvert Section from STA.: 300 + 00 to STA.: 330 + 00, From About 9' to 11' Above the Finished Floor Elevation

SET INDEX:	Set 1 of 1	BATCH TIME:	9:02 a.m.	AIR CONTENT (%):	NA
SUPPLIER:	CEMEX	SAMPLE TIME:	9:45 a.m.	UNIT WEIGHT (pcf):	NA
TRUCK NO:	10035601	SAMPLE TEMP. (°F):	78	FIELD CURED (day):	41
TICKET NO:	42801152	AMBIENT TEMP. (°F):	63	SAMPLE TYPE:	Mortar Cube
SAMPLED AT (cu yds):	6	SLUMP (in.):	NA	SAMPLE SIZE(in.):	2 x 2
DESIGN STR.(psi):	2,500				
PRODUCT NO.:	1421915				

SPECIMEN NUMBER	DATE OF TEST	AGE (days)	LOAD (lbs)	DIAMETER (in)	AREA (in. ²)	STRENGTH (psi)	PERCENT OF DESIGN	FRACTURE TYPE	TESTED BY
25	11/13/2014	7	16,575	NA	4.00	4,140	166	Type 3	R. Rodriguez
26	11/13/2014	7	17,160	NA	4.00	4,290	172	Type 3	R. Rodriguez
27	11/13/2014	7	14,555	NA	4.00	3,640	146	Type 3	R. Rodriguez
28	12/04/2014	28							
29	12/04/2014	28							
30	12/04/2014	28							

NOTE: Some information on this test report provided by others. Testing and reporting was conducted in general accordance with the following applicable A.S.T.M. references: C31, C39, C109, C138, C143, C172, C173, C231, C495, C1019, C1064, and C1231.

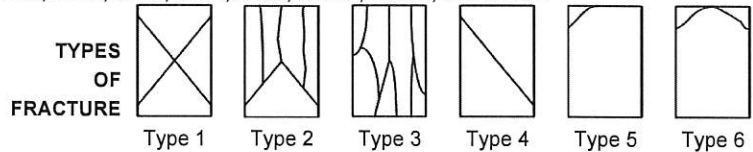

REMARKS: Stanley w/Foremost Paving, Inc., was verbally notified of field test results. ND-Not Determined; NP-Not Provided; NA-Not Applicable.

NOTICE: Raba Kistner Consultants, Inc. considers the data and information contained in this report to be proprietary. This information is intended only for the use of the recipient(s) named herein. Test results presented herein relate only to those items tested. This document and any information contained herein shall not be disclosed and shall not be duplicated or used in whole or in part for any purpose other than to validate test results without written approval from Raba Kistner Consultants, Inc.

COPIES TO: Above (1)
jaime@rgec.net(2)
diego@fpitex.com(3)
rgutierrez@rgutierrezengineering.com(1)
jimmie@fpitex.com(1)
diego@fpitex.com(1)

RABA KISTNER CONSULTANTS, INC.



Updated By: MMR 11/14/2014 2:26:49PM

Austin • Brownsville • Dallas • El Paso • Houston • McAllen • Mexico • New Braunfels • Salt Lake City • San Antonio



LABORATORY TEST REPORT



Raba Kistner Consultants Inc.
800 East Hackberry
McAllen, Texas 78501
(956) 682-5332 • FAX(956) 682-5487
www.rkci.com
TBPE Firm F-3257

Compressive Strength Test

ATTN.: MR. RAMIRO GUTIERREZ, P.E., PRESIDENT
TO: R. GUTIERREZ ENGINEERING CORPORATION
130 E. PARK AVENUE
PHARR, TEXAS 78577

PROJECT NO.: AMD14-089-00
CAST DATE: 11/06/2014
ASSIGNMENT NO.: M14-013727
REPORT VERSION: A
TECHNICIAN: VICTOR SALINAS III

PROJECT: Hidalgo County DD #1 Mission Inlet Arch Culvert Aluminum Liner Plate Re-Line, McAllen, Hidalgo County, Tx.

SAMPLE LOCATION: Grout for Inlet Arch Culvert Section from STA.: 300 + 00 to STA.: 330 + 00, From About 9' to 11' Above the Finished Floor Elevation

SET INDEX:	Set 1 of 1	BATCH TIME:	9:02 a.m.	AIR CONTENT (%):	NA
SUPPLIER:	CEMEX	SAMPLE TIME:	9:45 a.m.	UNIT WEIGHT (pcf):	NA
TRUCK NO:	10035601	SAMPLE TEMP. (°F):	78	FIELD CURED (day):	41
TICKET NO:	42801152	AMBIENT TEMP. (°F):	63	SAMPLE TYPE:	Mortar Cube
SAMPLED AT (cu yds):	6	SLUMP (in.):	NA	SAMPLE SIZE(in.):	2 x 2
DESIGN STR.(psi):	2,500				
PRODUCT NO.:	1421915				

SPECIMEN NUMBER	DATE OF TEST	AGE (days)	LOAD (lbs)	DIAMETER (in)	AREA (in. ²)	STRENGTH (psi)	PERCENT OF DESIGN	FRACTURE TYPE	TESTED BY
25	11/13/2014	7	16,575	NA	4.00	4,140	166	Type 3	R. Rodriguez
26	11/13/2014	7	17,160	NA	4.00	4,290	172	Type 3	R. Rodriguez
27	11/13/2014	7	14,555	NA	4.00	3,640	146	Type 3	R. Rodriguez
28	12/04/2014	28	22,630	NA	4.00	5,660	226	Type 3	A. Hernandez
29	12/04/2014	28	21,860	NA	4.00	5,470	219	Type 3	A. Hernandez
30	12/04/2014	28	22,110	NA	4.00	5,530	221	Type 3	A. Hernandez

NOTE: Some information on this test report provided by others. Testing and reporting was conducted in general accordance with the following applicable A.S.T.M. references: C31, C39, C109, C138, C143, C172, C173, C231, C495, C1019, C1064, and C1231.

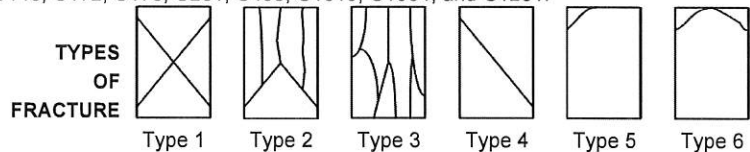

REMARKS: Stanley w/Foremost Paving, Inc., was verbally notified of field test results. ND-Not Determined; NP-Not Provided; NA-Not Applicable.

NOTICE: Raba Kistner Consultants, Inc. considers the data and information contained in this report to be proprietary. This information is intended only for the use of the recipient(s) named herein. Test results presented herein relate only to those items tested. This document and any information contained herein shall not be disclosed and shall not be duplicated or used in whole or in part for any purpose other than to validate test results without written approval from Raba Kistner Consultants, Inc.

COPIES TO: Above (1)
jaime@rgec.net(2)
diego@fpitex.com(3)
rgutierrez@rgutierrezengineering.com(1)
jimmie@fpitex.com(1)
diego@fpitex.com(1)

RABA KISTNER CONSULTANTS, INC.



Updated By: MMR 12/4/2014 2:01:32PM

Austin • Brownsville • Dallas • El Paso • Houston • McAllen • Mexico • New Braunfels • Salt Lake City • San Antonio



LABORATORY TEST REPORT

Compressive Strength Test



Raba Kistner Consultants Inc.
800 East Hackberry
McAllen, Texas 78501
(956) 682-5332 • FAX(956) 682-5487
www.rkci.com
TBPE Firm F-3257

ATTN.: MR. RAMIRO GUTIERREZ, P.E., PRESIDENT
TO: R. GUTIERREZ ENGINEERING CORPORATION
130 E. PARK AVENUE
PHARR, TEXAS 78577

PROJECT NO.: AMD14-089-00
CAST DATE: 11/10/2014
ASSIGNMENT NO.: M14-013743
REPORT VERSION: A
TECHNICIAN: ARMANDO RODRIGUEZ JR

PROJECT: Hidalgo County DD #1 Mission Inlet Arch Culvert Aluminum Liner Plate Re-Line, McAllen, Hidalgo County, Tx.

SAMPLE LOCATION: Grout for Inlet Arch Culvert Section Near STA.: 30 + 00, From About 11' to 13' Above the Finished Floor Elevation

SET INDEX:	Set 1 of 1	BATCH TIME:	11:00 a.m.	AIR CONTENT (%):	NA
SUPPLIER:	CEMEX	SAMPLE TIME:	12:00 p.m.	UNIT WEIGHT (pcf):	NA
TRUCK NO:	10036857	SAMPLE TEMP. (°F):	77	FIELD CURED (day):	1
TICKET NO:	42805812	AMBIENT TEMP. (°F):	76	SAMPLE TYPE:	Mortar Cube
SAMPLED AT (cu yds):	5	SLUMP (in.):	8.00	SAMPLE SIZE(in.):	2 x 2
DESIGN STR.(psi):	2,500				
PRODUCT NO.:	1421915				

SPECIMEN NUMBER	DATE OF TEST	AGE (days)	LOAD (lbs)	DIAMETER (in)	AREA (in. ²)	STRENGTH (psi)	PERCENT OF DESIGN	FRACTURE TYPE	TESTED BY
21	11/17/2014	7	16,465	NA	4.00	4,120	165	Type 1	E. Arredondo
22	11/17/2014	7	16,570	NA	4.00	4,140	166	Type 1	E. Arredondo
23	11/17/2014	7	17,970	NA	4.00	4,490	180	Type 1	E. Arredondo
24	12/08/2014	28							
25	12/08/2014	28							
26	12/08/2014	28							

NOTE: Some information on this test report provided by others. Testing and reporting was conducted in general accordance with the following applicable A.S.T.M. references: C31, C39, C109, C138, C143, C172, C173, C231, C495, C1019, C1064, and C1231.

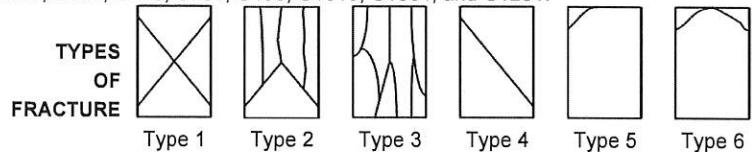

REMARKS: Stanley w/Foremost Paving, Inc., was verbally notified of field test results. ND-Not Determined; NP-Not Provided; NA-Not Applicable.

NOTICE: Raba Kistner Consultants, Inc. considers the data and information contained in this report to be proprietary. This information is intended only for the use of the recipient(s) named herein. Test results presented herein relate only to those items tested. This document and any information contained herein shall not be disclosed and shall not be duplicated or used in whole or in part for any purpose other than to validate test results without written approval from Raba Kistner Consultants, Inc.

COPIES TO: Above (1)
jaime@rgec.net(2)
diego@fpitex.com(3)
rgutierrez@rgutierrezengineering.com(1)
jimmie@fpitex.com(1)
diego@fpitex.com(1)

RABA KISTNER CONSULTANTS, INC.



Updated By: MMR 11/18/2014 10:48:20AM

Austin • Brownsville • Dallas • El Paso • Houston • McAllen • Mexico • New Braunfels • Salt Lake City • San Antonio



LABORATORY TEST REPORT

Compressive Strength Test



Raba Kistner Consultants Inc.
800 East Hackberry
McAllen, Texas 78501
(956) 682-5332 • FAX(956) 682-5487
www.rkci.com
TBPE Firm F-3257

ATTN.: MR. RAMIRO GUTIERREZ, P.E., PRESIDENT
TO: R. GUTIERREZ ENGINEERING CORPORATION
130 E. PARK AVENUE
PHARR, TEXAS 78577

PROJECT NO.: AMD14-089-00
CAST DATE: 11/10/2014
ASSIGNMENT NO.: M14-013743
REPORT VERSION: A
TECHNICIAN: ARMANDO RODRIGUEZ JR

PROJECT: Hidalgo County DD #1 Mission Inlet Arch Culvert Aluminum Liner Plate Re-Line, McAllen, Hidalgo County, Tx.

SAMPLE LOCATION: Grout for Inlet Arch Culvert Section Near STA.: 30 + 00, From About 11' to 13' Above the Finished Floor Elevation

SET INDEX:	Set 1 of 1	BATCH TIME:	11:00 a.m.	AIR CONTENT (%):	NA
SUPPLIER:	CEMEX	SAMPLE TIME:	12:00 p.m.	UNIT WEIGHT (pcf):	NA
TRUCK NO:	10036857	SAMPLE TEMP. (°F):	77	FIELD CURED (day):	1
TICKET NO:	42805812	AMBIENT TEMP. (°F):	76	SAMPLE TYPE:	Mortar Cube
SAMPLED AT (cu yds):	5	SLUMP (in.):	8.00	SAMPLE SIZE(in.):	2 x 2
DESIGN STR.(psi):	2,500				
PRODUCT NO.:	1421915				

SPECIMEN NUMBER	DATE OF TEST	AGE (days)	LOAD (lbs)	DIAMETER (in)	AREA (in. ²)	STRENGTH (psi)	PERCENT OF DESIGN	FRACTURE TYPE	TESTED BY
21	11/17/2014	7	16,465	NA	4.00	4,120	165	Type 1	E. Arredondo
22	11/17/2014	7	16,570	NA	4.00	4,140	166	Type 1	E. Arredondo
23	11/17/2014	7	17,970	NA	4.00	4,490	180	Type 1	E. Arredondo
24	12/08/2014	28	22,425	NA	4.00	5,610	224	Type 3	A. Hernandez
25	12/08/2014	28	21,615	NA	4.00	5,400	216	Type 3	A. Hernandez
26	12/08/2014	28	22,160	NA	4.00	5,540	222	Type 3	A. Hernandez

NOTE: Some information on this test report provided by others. Testing and reporting was conducted in general accordance with the following applicable A.S.T.M. references: C31, C39, C109, C138, C143, C172, C173, C231, C495, C1019, C1064, and C1231.

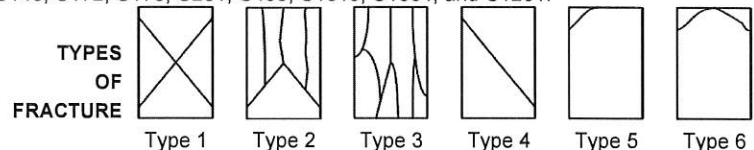

REMARKS: Stanley w/Foremost Paving, Inc., was verbally notified of field test results. ND-Not Determined; NP-Not Provided; NA-Not Applicable.

NOTICE: Raba Kistner Consultants, Inc. considers the data and information contained in this report to be proprietary. This information is intended only for the use of the recipient(s) named herein. Test results presented herein relate only to those items tested. This document and any information contained herein shall not be disclosed and shall not be duplicated or used in whole or in part for any purpose other than to validate test results without written approval from Raba Kistner Consultants, Inc.

COPIES TO: Above (1)
jaime@rgec.net(2)
diego@fpitex.com(3)
rgutierrez@rgutierrezengineering.com(1)
jimmie@fpitex.com(1)
diego@fpitex.com(1)

RABA KISTNER CONSULTANTS, INC.

Carlos Ceballos Jr.

BY: _____
12/08/2014



LABORATORY TEST REPORT

Compressive Strength Test



Raba Kistner Consultants Inc.
800 East Hackberry
McAllen, Texas 78501
(956) 682-5332 • FAX(956) 682-5487
www.rkci.com
TBPE Firm F-3257

ATTN.: MR. RAMIRO GUTIERREZ, P.E., PRESIDENT
TO: R. GUTIERREZ ENGINEERING CORPORATION
130 E. PARK AVENUE
PHARR, TEXAS 78577

PROJECT NO.: AMD14-089-00
CAST DATE: 11/10/2014
ASSIGNMENT NO.: M14-013743
REPORT VERSION: B
TECHNICIAN: ARMANDO RODRIGUEZ JR

PROJECT: Hidalgo County DD #1 Mission Inlet Arch Culvert Aluminum Liner Plate Re-Line, McAllen, Hidalgo County, Tx.

SAMPLE LOCATION: Grout for Inlet Arch Culvert Section Near STA.: 30 + 00, From About 11' to 13' Above the Finished Floor Elevation

SET INDEX:	Set 1 of 1				
SUPPLIER:	CEMEX	BATCH TIME:	11:00 a.m.	AIR CONTENT (%):	NA
TRUCK NO:	10036857	SAMPLE TIME:	12:00 p.m.	UNIT WEIGHT (pcf):	NA
TICKET NO:	42805812	SAMPLE TEMP. (°F):	77	FIELD CURED (day):	1
SAMPLED AT (cu yds):	5	AMBIENT TEMP. (°F):	76	SAMPLE TYPE:	Mortar Cube
DESIGN STR.(psi):	2,500	SLUMP (in.):	8.00	SAMPLE SIZE(in.):	2 x 2
PRODUCT NO.:	1421915				

SPECIMEN NUMBER	DATE OF TEST	AGE (days)	LOAD (lbs)	DIAMETER (in)	AREA (in. ²)	STRENGTH (psi)	PERCENT OF DESIGN	FRACTURE TYPE	TESTED BY
*31	11/17/2014	7	16,465	NA	4.00	4,120	165	Type 1	E. Arredondo
*32	11/17/2014	7	16,570	NA	4.00	4,140	166	Type 1	E. Arredondo
*33	11/17/2014	7	17,970	NA	4.00	4,490	180	Type 1	E. Arredondo
*34	12/08/2014	28	22,425	NA	4.00	5,610	224	Type 3	A. Hernandez
*35	12/08/2014	28	21,615	NA	4.00	5,400	216	Type 3	A. Hernandez
*36	12/08/2014	28	22,160	NA	4.00	5,540	222	Type 3	A. Hernandez

NOTE: Some information on this test report provided by others. Testing and reporting was conducted in general accordance with the following applicable A.S.T.M. references: C31, C39, C109, C138, C143, C172, C173, C231, C495, C1019, C1064, and C1231.

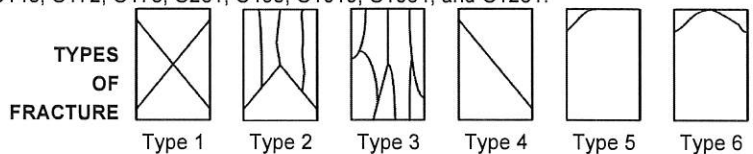

REMARKS: Stanley w/Foremost Paving, Inc., was verbally notified of field test results. ND-Not Determined; NP-Not Provided; NA-Not Applicable. *CORRECTED REPORT 12-09-14; TEST NOS. 21-26 WERE CHANGED TO 31-36*

NOTICE: Raba Kistner Consultants, Inc. considers the data and information contained in this report to be proprietary. This information is intended only for the use of the recipient(s) named herein. Test results presented herein relate only to those items tested. This document and any information contained herein shall not be disclosed and shall not be duplicated or used in whole or in part for any purpose other than to validate test results without written approval from Raba Kistner Consultants, Inc.

COPIES TO: Above (1)
jaime@rgec.net(2)
diego@fpitex.com(3)
rgutierrez@rgutierrezengineering.com(1)
jimmie@fpitex.com(1)
diego@fpitex.com(1)

RABA KISTNER CONSULTANTS, INC.



BY: *Carlos Ceballos Jr.*
12/09/2014



Updated By: MMR 12/9/2014 11:22:47AM

Austin • Brownsville • Dallas • El Paso • Houston • McAllen • Mexico • New Braunfels • Salt Lake City • San Antonio



Certificate of Substantial Completion

PROJECT: MISSION INLET ARCH CULVERT- ALUMINUM LINER PLATE RELINE
PROJECT NUMBER: ENG14.007
OWNER: HIDALGO COUNTY DRAINAGE DISTRICT NO. 1
CONTRACTOR: FOREMOST PAVING, INC.

The Work performed under this Contract has been reviewed and found, to the Engineer’s best knowledge, information and belief, to be substantially complete. Substantial Completion is the stage in the progress of the Work when the Work or designated portion is sufficiently complete in accordance with the Contract Documents so that the owner can occupy or utilize the Work for its intended use. The date of Substantial Completion of the Project or portion designated above is the date of issuance established by this Certificate, which is also the date of commencement of applicable warranties required by the Contract Documents, except as stated below: Construction time is stopped at the day of Issuance.

Ramiro Gutierrez, P.E. _____ *Ramiro G. P.E.* _____ 11/20/2014 _____
Engineer By Date of Issuance

A list of items to be completed or corrected is attached hereto. The failure to include any items on such list does not alter the responsibility of the Contractor to complete all Work in accordance with the Contract Documents. Unless otherwise agreed to in writing, the date of commencement of warranties for items on the attached list will be the date of issuance of the final Certificate of Payment or the date of final payment.

As indicated in the attached punch list letter, no pending items were found at the walk through inspection conducted on November 20, 2014 of the above mentioned project.

Foremost Paving, Inc. _____ *Jimmie K. McPherson* _____ 11/20/2014 _____
Contractor By Jimmie K. McPherson Date
Project Manager

The Owner accepts the Work or designated portion as substantially complete and will assume full possession thereof, in accordance with the contract documents.

Hidalgo County Drainage District No. 1 _____ _____
Owner By Date

R. Gutierrez Engineering Corporation

Texas Engineering Firm Number: F-486
Texas Surveying Firm Number: 101650-00

November 24, 2014

Mr. Jimmie McPherson
Foremost Paving, Inc.
P.O. Box 3244
McAllen, TX 78502

Subject: Mission Inlet Arch Culvert – Aluminum Liner Plate Re-Line
Contract Number: HCDD1-14-025-09-09

Dear Mr. McPherson:

A walk through inspection of the above mentioned project was conducted on November 20, 2014 for the purpose of formulating a punch list of pending items required for construction completion and acceptance by Hidalgo County Drainage District No. 1.

Attendees: Mr. Ramiro Gutierrez, PE – R. Gutierrez Engineering Corporation
Mr. Hernan Lugo, PE – R. Gutierrez Engineering Corporation
Mr. Noe Saldivar, PE – Hidalgo Drainage District No. 1
Mr. Diego Gonzalez – Foremost Paving, Inc.
Mr. Stanley McFarland – Foremost Paving, Inc.

The pending items are as follows:

1. No pending items found at this time.

Should you have any questions, please feel free to contact me at (956) 782-2557 or hlugo@rgec.net

Sincerely,



Hernan Lugo, PE
Senior Project Manager

Cc: Godfrey Garza, Hidalgo County Drainage District No.1
Hector "Tito" Palacios, Hidalgo County Precinct No.2

R. Gutierrez Engineering Corporation

Transmittal Form

TO: Claudette Guerrero
Hidalgo County Drainage District 1

FROM: Javier Gutierrez
 SUBJECT: Mission Inlet Arch Culvert - Aluminum Liner Plate Re-Line
 PROJECT NO.: ENG14.007
 DATE: December 22, 2014

WE ARE SENDING YOU ATTACHED UNDER SEPARATE COVER VIA Hand Delivery THE FOLLOWING ITEMS:

<input type="checkbox"/> BLUEPRINTS	<input type="checkbox"/> PLANS	<input type="checkbox"/> SHOP DRAWINGS	<input type="checkbox"/> CD
<input type="checkbox"/> CHANGE ORDER	<input type="checkbox"/> SAMPLES	<input checked="" type="checkbox"/> PAYMENT REQUEST	<input type="checkbox"/> OTHER:
<input type="checkbox"/> BID TABULATION	<input type="checkbox"/> CONTRACT DOCUMENTS	<input type="checkbox"/> RECORD DRAWINGS	<input type="checkbox"/> 3 1/2" DISKETTE

QUANTITY / SETS	DATED	ITEM DESCRIPTION
1		Payment Request #1 with Backup Documents
1		Certificate of Substantial Completion

THESE ARE TRANSMITTED AS CHECKED BELOW:

<input type="checkbox"/> FOR BIDS DUE	<input type="checkbox"/> APPROVED AS NOTED	<input type="checkbox"/> FOR YOUR RECORDS
<input type="checkbox"/> FOR APPROVAL	<input type="checkbox"/> APPROVED AS SUBMITTED	<input type="checkbox"/> FOR YOUR ACKNOWLEDGEMENT
<input type="checkbox"/> FOR YOUR USE	<input type="checkbox"/> RETURN FOR CORRECTIONS	<input type="checkbox"/> RESUBMIT FOR APPORVAL
<input type="checkbox"/> AS REQUESTED	<input type="checkbox"/> FOR FURTHER PROCESSING	<input type="checkbox"/> ON LOAN
<input type="checkbox"/> FOR REVIEW AND COMMENT	<input type="checkbox"/> FOR SIGNATURE	<input type="checkbox"/> OTHER

RECEIVED
 HIDALGO COUNTY
 DRAINAGE DISTRICT #1

DEC 22 2014

2:15 AM/PM

BY: Javier Gutierrez

COMMENTS:

Copy Distribution: file

Received by: _____

HIDALGO COUNTY DRAINAGE DISTRICT NUMBER ONE

902 NORTH DOOLITTLE

EDINBURG, TEXAS 78542

(958) 292-7080

FAX (958) 292-7089



GODFREY GARZA, JR.
MANAGER

INVOICE PROCESSING CHECKLIST

Date Received: 12/22/2014

Engineer/Firm Name: Foremost Paving, Inc.

Project Name/Number: Mission Inlet Arch Culvert- Aluminum Liner Plate
Reline

Invoice No: Application For Retainage

Logged in and Scanned: 221PM 12/23 By: R. Arce Forwarded to: Joey Garza

Engineer	Name	Date	Comment
Scope of work reviewed			

Accounting	Name	Date	Comment
Encumbrance			
Purchase Order Attached			
Audit			
Final Approval for Agenda			

	Name	Date	Comment
Placed on Agenda			

Additional Comments: _____

DEC 22 2014

2:15 AM (PM)

APPLICATION FOR RETAINAGE

BY: Joey Garcia (OWNER)
(CONTRACTOR)

To: Hidalgo County Drainage District No. 1
From: Foremost Paving, Inc.
Contract: HCDD1-14-025-09-09
Project: MISSION INLET ARCH CULVERT- ALUMINUM LINER PLATE RELINE
OWNER's Contract No. HCDD1-14-025-09-09
For Work accomplished through the date of: November 22, 2014 ENGINEER's Project No.: ENG14.007

1. Original Contract Price:	\$ 169,900.00
2. Net change by Change Orders and Written Agreements (+ or -):	\$ -
3. Current Contract Price (1 plus 2):	\$ 169,900.00
4. Total completed and stored to date:	\$ 169,900.00
5. Retainage (per Agreement):	
<u>5% of completed Work:</u>	\$ -
<u>5% of stored material:</u>	\$ -
Total Retainage:	\$ -
6. Total completed and stored to date less retainage (4 minus 5):	\$ 169,900.00
7. Less previous Application for Payments:	\$ (161,405.00)
8. Balance to Finish:	\$ -
9. AMOUNT DUE THIS APPLICATION (6 MINUS 7):	\$ 8,495.00

Accompanying Documentation:

CONTRACTOR'S Certification:

The undersigned CONTRACTOR certifies that (1) all previous progress payments received from OWNER on account of Work done under the Contract referred to above have been applied on account to discharge CONTRACTOR's legitimate obligations incurred in connection with Work covered by prior Applications for Payment numbered 1 through RETAINAGE inclusive; (2) title of all Work, materials and equipment incorporated in said Work or otherwise listed in or covered by this Application for Payment will pass to OWNER at time of payment free and clear of all Liens, security interests and encumbrances (except such as are covered by a Bond acceptable to OWNER indemnifying OWNER against any such Lien, security interest or encumbrance); and (3) all Work covered by this Application for Payment is in accordance with the Contract Documents and not defective.

Dated 12/14/14 Foremost Paving, Inc.
CONTRACTOR

By: [Signature]

State of Texas
County of Hidalgo
Subscribed and sworn to before me this 4th
day of December 2014

[Signature]
Notary Public
My Commission expires: March 19, 2018



Payment of the above AMOUNT DUE THIS APPLICATION is recommended.

Dated 12/19/14 R. GUTIERREZ ENGINEERING CORPORATION
ENGINEER

By: Rain [Signature], P.E.

Schedule of Values

Contractor Name: Foremost Paving, Inc.
 Starting Date: October 22, 2014
 Project Ending Date: December 20, 2014
 Project Desc: MISSION INLET ARCH CULVERT- ALUMINUM LINER PLATE RELINE
 Retainage Percent: 5%

Application: RETAINAGE
 Application Date: 11/22/2014
 Period To: ENG14.007
 Engineer's Project No.: R. Gutierrez Eng. Corp.
 Engineer Firm

Summary										
Contract Number	Description	Original Schedule Value	Application #1	Retainage for App #1	Payment for Application #1	Total Completed to Date	Retainage to Date	Total Completed Less Retainage	Previous Payments	Balance To Finish
HCDD1-14-025-09-09	MISSION INLET ARCH CULVERT- ALUMINUM LINER PLATE RELINE	\$ 169,900.00	\$ 169,900.00	\$ 8,495.00	\$ 161,405.00	\$ 169,900.00	\$ 8,495.00	\$ 161,405.00	\$ 161,405.00	\$ -
TOTALS:		\$ 169,900.00	\$ 169,900.00	\$ 8,495.00	\$ 161,405.00	\$ 169,900.00	\$ 8,495.00	\$ 161,405.00	\$ 161,405.00	\$ -

Contractor Name: Foremost Paving, Inc.
 Starting Date: October 22, 2014
 Project Ending Date: December 20, 2014
 Project Desc: MISSION INLET ARCH CULVERT - ALUMINIUM LINER PLATE RELINE

Application: RETAINAGE
 Application Date: November 22, 2014
 Period To: November 22, 2014
 Engineers / County Project No.: ENG14.007

No.	Item Code	Description	Unit	Original Schedule Value		Application #1			Balance To Finish		
				Original Rates	Quan	Dollars	Monthly Quan	QTY to Date	Item Cost (Monthly)	Total to Date	Quan
1	xx	Installation of Aluminum Liner Plate Reline to reinforce existing ALSP in the Mission Inlet Channel at South McCoil Road Crossing. Contractor to furnish all labor, equipment and materials necessary for proper assembly and installation of the structure.	LS	\$ 169,900.00	1.00	\$ 169,900.00	1.00	1.00	\$ 169,900.00	0.00	\$ -
TOTAL BASE AMOUNTS:				\$		\$ 169,900.00			\$ 169,900.00		\$ -

Printed Name: Javier Gutierrez

Signature: 

Date: 12-19-14

CERTIFICATE OF CONSTRUCTION COMPLETION

THIS IS TO CERTIFY THAT ON 20th DAY OF November 2014, A FINAL INSPECTION was made of the project herein described:

CONTRACT

CONTRACT DATE: September 9, 2014
 OWNER: Hidalgo County Drainage District No. 1
 CONSTRUCTION CONTRACTOR: Foremost Paving, Inc.
 OF THE CITY OF Alamo, STATE OF Texas

PROJECT DESCRIPTION

CONSTRUCTION OF: Mission Inlet Arch Culvert – Aluminum Liner Plate Re-Line
 CONTRACT NO.: HCDD1-14-025-09-09
 LOCATED IN OR NEAR THE CITY/PRECINCT OF: McAllen, Texas / Hidalgo County Precinct 2

THIS IS TO CERTIFY:

1. That the work has been completed in accordance with the plans and specifications and all addenda, change orders, supplemental agreements thereto, and with the following exceptions:
None
2. That the sum of Zero and 00/100 Dollars – (\$0.00) be deducted from the final payment of the Contractor is a fair and equitable settlement for the foregoing except work.
3. That the contractor has presented a "Certificate of Release" stating under oath, that all claims arising out of the performance of work have been fulfilled, and the OWNER is released from all claims arising under or by virtue of said contract.
4. That the CONTRACTOR has presented in behalf of itself and its sureties, satisfactory evidence that it is bound to repair, replace, and make good any faulty workmanship and/or materials discovered in the work within a period of one year from this date, as provided in said contract.

5. AMOUNT OF ORIGINAL CONTRACT	\$	169,900.00
PRESENT AMOUNT OF CONTRACT	\$	169,900.00
TOTAL AMOUNT OF CONTRACT EARNED TO DATE	\$	169,900.00
LESS: PREVIOUS PAYMENTS	\$	161,405.00
BALANCE	\$	8,495.00
AUTHORIZED DEDUCTIONS	\$	0.00
AMOUNT OF FINAL PAYMENT	\$	8,495.00

6. That the final payment in the amount of Eight Thousand Four Hundred Ninety-Five and 00/100 Dollars (\$9,495.00) is now due and payable.

Ramiro G. Gutierrez, P.E.
Engineer's Signature
Ramiro Gutierrez, P.E.

CONCURRED BY:

Jimmie R. McPherson
Foremost Paving, Inc.

BY: Jimmie R. McPherson

TITLE: Project Manager

CONCURRED BY:

Hidalgo County Judge

**CONTRACTOR'S AFFIDAVIT OF
PAYMENTS OF DEBTS AND CLAIMS**

PROJECT: HCDD #1 Mission Inlet Culvert
OWNER: Hidalgo County Drainage District No. 1
CONTRACTOR: Foremost Paving, Inc.
ENGINEER: R. Gutierrez Engineering Corporation

PROJECT NO. RFB No. HCDD1
-14-025-08-15

The Contactor in accordance with the Contract Documents, hereby certifies that, except as listed below, all obligations for all materials and equipment furnished, for all work labor, and services performed, and for all known indebtedness and claims against the Contractor for damages arising in any manner in connection with the performance of the Contract referenced above for which the Owner or his property might in any way be held responsible have been paid in full or have otherwise been satisfied in full.

EXCEPTIONS: (If none, write "NONE". The Contractor shall furnish a bond acceptable to the Owner for each exception.) None

CONTRACTOR

Foremost Paving, Inc.

By

James R. Mephan
Title Project Manager

Subscribed and sworn to before me this

19

day of December

Notary Public:

Priscilla Garcia

My Commission Expires:

March 19, 2018



CONTRACTOR'S AFFIDAVIT OF RELEASE OF LIENS

PROJECT: Mission Inlet Arch Culvert - Aluminum Liner Plate Re-Line **PROJECT NO.** HCDD1-14-025-09-09
OWNER: Hidalgo County Drainage Dist No. 1
CONTRACTOR: Foremost Paving, Inc.
ENGINEER: R. Gutierrez Engineering Corp.

The Contractor, in accordance with the Contract Documents, and in consideration for the full and final payment to the Contractor for all services in connection with the project, does hereby waive and release any and all liens, or any and all claims to liens which the Contractor may have on or affecting the project as a result of its contract(s) for the Project or for performing labor and/or furnishing materials in any way connected with the construction of any aspect of the project. The Contractor further certifies and warrants that all subcontractors of labor and/or materials for the Project, except as listed below, have been paid in full for all labor and/or materials supplied to, for through or at the direct or indirect request of the Contractor prior to, through and including the date of this affidavit.

EXCEPTIONS: (If none, write "NONE". The Contractor shall furnish a bond acceptable to the Owner for each exception.)

NONE

CONTRACTOR Foremost Paving, Inc.

By 
Title Employee

Subscribed and sworn to before me this 24th day of November 2014

Notary Public: 

My Commission Expires:
March 19, 2018



CONSENT OF SURETY COMPANY TO FINAL PAYMENT

OWNER
ARCHITECT
CONTRACTOR
SURETY
OTHER

AIA DOCUMENT G707

PROJECT: Hidalgo County Drainage District No. 1 - Mission Inlet Arch Culvert
(name, address) Aluminum Liner Plate Reline

TO (Owner):

[]

ARCHITECT'S PROJECT NO:
CONTRACT FOR:

Hidalgo County Drainage District No. 1
902 Doolittle
Edinburg, TX 78542

CONTRACT DATE:

[]

CONTRACTOR: Foremost Paving, Inc.

In accordance with the provisions of the Contract between the Owner and the Contractor as indicated above, the (here insert name and address of Surety as it appears in the bond).

Great American Insurance Company
2435 N. Central Expressway, Ste 600, Richardson, TX 75080

, SURETY COMPANY,

on bond of (here insert name and address of Contractor)

Foremost Paving, Inc.
P.O. Box 29, Weslaco, TX 78596

, CONTRACTOR,

hereby approves of the final payment to the Contractor, and agrees that final payment to the Contractor shall not relieve the Surety Company of any of its obligations to (here insert name and address of Owner)

Hidalgo County Drainage District No. 1
902 Doolittle Road, Edinburg, TX 78542

, OWNERS,

as set forth in the said Surety Company's bond.

IN WITNESS WHEREOF,
the Surety Company has hereunto set its hand this 2nd day of December 20 14 .

Great American Insurance Company
Surety Company

By: 
Signature of Authorized Representative

Peggy Gonzalez, Attorney-in-fact
Title

Attest:
(Seal):

NOTE: This form is to be used as a companion document to AIA DOCUMENT G706, CONTRACTOR'S AFFIDAVIT OF PAYMENT OF DEBTS AND CLAIMS, Current Edition

GREAT AMERICAN INSURANCE COMPANY®

Administrative Office: 301 E 4TH STREET • CINCINNATI, OHIO 45202 • 513-369-5000 • FAX 513-723-2740

The number of persons authorized by this power of attorney is not more than **FIVE**

No. 0 15621

POWER OF ATTORNEY

KNOW ALL MEN BY THESE PRESENTS: That the GREAT AMERICAN INSURANCE COMPANY, a corporation organized and existing under and by virtue of the laws of the State of Ohio, does hereby nominate, constitute and appoint the person or persons named below, each individually if more than one is named, its true and lawful attorney-in-fact, for it and in its name, place and stead to execute on behalf of the said Company, as surety, any and all bonds, undertakings and contracts of suretyship, or other written obligations in the nature thereof; provided that the liability of the said Company on any such bond, undertaking or contract of suretyship executed under this authority shall not exceed the limit stated below.

Name	Address	Limit of Power
RAY HUGHSTON PEGGY GONZALEZ	ALL OF	ALL
CHRISTOPHER J. HUGHSTON MARY EDWARDS	BROWNSVILLE,	\$100,000,000.00
DAVID C. HUGHSTON	TEXAS	

This Power of Attorney revokes all previous powers issued on behalf of the attorney(s)-in-fact named above.

IN WITNESS WHEREOF the GREAT AMERICAN INSURANCE COMPANY has caused these presents to be signed and attested by its appropriate officers and its corporate seal hereunto affixed this **24TH** day of **FEBRUARY**, 2014

Attest

GREAT AMERICAN INSURANCE COMPANY



My L C. B.
Assistant Secretary

David C. Kitchin
Divisional Senior Vice President

STATE OF OHIO, COUNTY OF HAMILTON - ss:

DAVID C. KITCHIN (877-377-2405)

On this **24TH** day of **FEBRUARY**, 2014

, before me personally appeared DAVID C. KITCHIN, to me known, being duly sworn, deposes and says that he resides in Cincinnati, Ohio, that he is a Divisional Senior Vice President of the Bond Division of Great American Insurance Company, the Company described in and which executed the above instrument; that he knows the seal of the said Company; that the seal affixed to the said instrument is such corporate seal; that it was so affixed by authority of his office under the By-Laws of said Company, and that he signed his name thereto by like authority.



Shelle Clontz
Notary Public, State of Ohio
My Commission Expires 08-09-2015

Shelle Clontz

This Power of Attorney is granted by authority of the following resolutions adopted by the Board of Directors of Great American Insurance Company by unanimous written consent dated June 9, 2008.

RESOLVED: That the Divisional President, the several Divisional Senior Vice Presidents, Divisional Vice Presidents and Divisional Assistant Vice Presidents, or any one of them, be and hereby is authorized, from time to time, to appoint one or more Attorneys-in-Fact to execute on behalf of the Company, as surety, any and all bonds, undertakings and contracts of suretyship, or other written obligations in the nature thereof; to prescribe their respective duties and the respective limits of their authority; and to revoke any such appointment at any time.

RESOLVED FURTHER: That the Company seal and the signature of any of the aforesaid officers and any Secretary or Assistant Secretary of the Company may be affixed by facsimile to any power of attorney or certificate of either given for the execution of any bond, undertaking, contract of suretyship, or other written obligation in the nature thereof, such signature and seal when so used being hereby adopted by the Company as the original signature of such officer and the original seal of the Company, to be valid and binding upon the Company with the same force and effect as though manually affixed.

CERTIFICATION

I, STEPHEN C. BERAHA, Assistant Secretary of Great American Insurance Company, do hereby certify that the foregoing Power of Attorney and the Resolutions of the Board of Directors of June 9, 2008 have not been revoked and are now in full force and effect.

Signed and sealed this **2nd** day of **December**, 2014 .



My L C. B.
Assistant Secretary



Dayton Office

ENGINEERING REPORT

TO: Contech Engineered Solutions LLC
2201 W. Royal Lane
Suite 170
Irving, Texas 75063

DATE: November 18, 2014

NO: 16842D-1-1114-05

ATTN: Mr. Orion Graham
Region Engineer

Re: Summary of Field Observation of the Installation of a 23' 1-7/8" Span by 11' 9-1/2" Rise Aluminum 2-Flange Tunnel Liner Plate Arch Liner from Station 3+00 to 3+30 in an Existing ALSP Single Radius Arch; McColl Road, McAllen, Hidalgo County, Texas; CBC Report No. 16842D-1-1114-05

The purpose of this report is to provide a summary of the field observations made by this office of the installation of the aluminum liner plate arch liner from Station 3+00 to 3+30 in the subject structure at the above referenced project. The design of this arch liner was previously provided in CBC Report No. 16268D-1-0514-05, dated May 30, 2014. A technician was provided by this office to field observe the arch liner installation, and the placement of concrete grout between the arch liner and the existing arch. The observation work was performed in accordance with CBC Quotation No. 14-593-05 dated August 15, 2014, and the terms and conditions of the Master Agreement for Engineering Services dated July 30, 2009.

A technician from CBC Engineers & Associates, Ltd. was on site from Sunday, October 26 through Monday, November 10, 2014 at which time the arch liner structure installation and grout placement were observed.

Initially, the aluminum "T" rails were installed and epoxy anchored to the top of the existing concrete pedestal walls on each side of the structure from Station 3+00 to 3+30. After the aluminum "T" rails were installed and anchored, the aluminum arch liner rings were assembled and installed inside the existing structure from Station 3+00 to 3+30. The bolts used to assemble the arch liner rings were installed to a torque of at least 100 ft-lbs. Once the rings of arch liner were installed, the void area inside the "T" rails in front of and behind the arch liner were filled with non-shrink grout. Upon the completion of the grout placement in the "T" rails, the CBC technician performed a set of laser shape measurements at five (5) stations within the installed arch liner prior to it being back-grouted (Stations 3+00, 3+08, 3+16, 3+22 and 3+30).

On Monday, November 3, 2014, the contractor commenced the pumping of concrete grout into the annulus between the outside of the arch liner plate and the inside of the existing structure. The grout was placed on alternating sides and at various locations down the length of the arch liner structure, through the open ends and through the grout ports, taking care that the grout level on one side was not more than one foot higher than the opposite side at any time or location. The grout was placed in maximum 24-inch lifts with each lift allowed to set-up prior to the addition of the subsequent lift. Temporary wood blocking was used at the top centerline of the arch liner to help maintain the liner shape during the grout placement with this wood blocking subsequently being removed prior to the placement of the last lift of grout. Temporary wood formwork was also installed on both the upstream and downstream ends of the liner to contain the lifts of liquid grout.

The CBC technician performed rise measurements of the installed arch liner (at the same above 5 stations) prior to grout placement and periodically during the grout placement as well as at the end of each pour. This procedure was continued by the contractor until the entire annulus between the arch liner and existing structure was filled with grout. During the grout placement, the contractor monitored the grout levels and locations outside of the arch liner through the open grout ports and through the open ends above each lift, as well as through soundings of the arch liner to insure that the grout was flowing evenly and that all void spaces were being filled. The grout placement was completed on Monday, November 10, 2014, and the contractor used a tremie pipe during the last grout lift placement to facilitate the filling of any voids outside the existing structure with grout.

After the completion of the placement of the final grout lift above the arch liner, the CBC technician performed laser shape measurements of the back-grouted arch at the same stations as measured prior to the grouting. These laser shape measurements, along with the rise measurements taken during the grouting process, showed that the shape of the arch liner remained essentially unchanged during the grout placement. The rise measurements and the laser shape measurements are attached herewith in Appendix C. The technician's field observation reports are attached in Appendix A and photographs are attached in Appendix B.

Based on the observations and measurements made by the CBC technician of the installation and grouting of the subject arch liner structure during the above described CBC observation periods, it is the opinion of this office that the arch liner structure has been installed in conformance with the design requirements and accepted industry standards, and that the observed in-place shape and condition of the arch liner structure will provide the intended in-service performance.

Our professional services have been performed in accordance with generally accepted geotechnical engineering principles and practices. No other warranty, expressed or implied, is made. This report has been prepared for the exclusive use of Contech Engineered Solutions LLC, for specific application to the structure herein described. Anyone reviewing this report must interpret and draw their own conclusions regarding specific construction techniques and methods chosen. CBC Engineers & Associates, Ltd. is not responsible for the independent conclusions, opinions or recommendations made by others.

If you have any questions, please contact us.

Respectfully submitted,

CBC Engineers & Associates, Ltd.



Mitchell T. Hardert, P.E.
Chief Engineer

MTH/lb

cc: Client (ograham@conteches.com)

cc: Jim Noll (jnoll@conteches.com)

1-File

APPENDIX A
OBSERVATION REPORTS

APPENDIX B

PHOTOGRAPHS

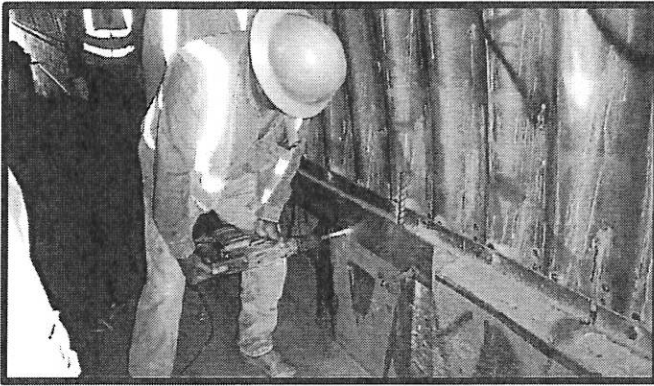

PHOTOGRAPH 1

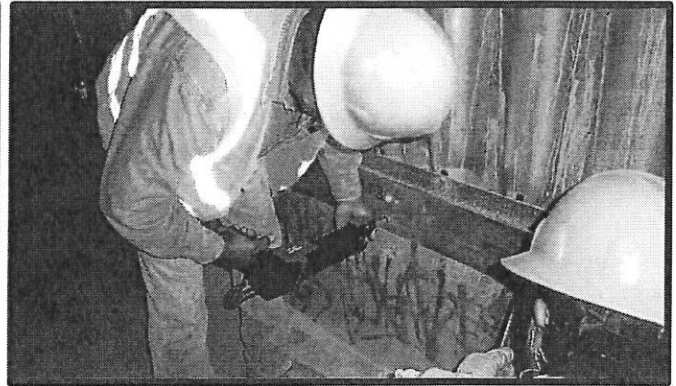

PHOTOGRAPH 2



PHOTOGRAPH 3



PHOTOGRAPH 4

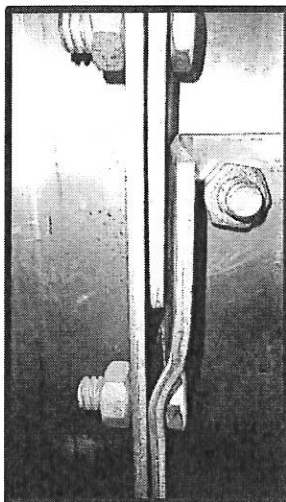

PHOTOGRAPH 5



PHOTOGRAPH 6

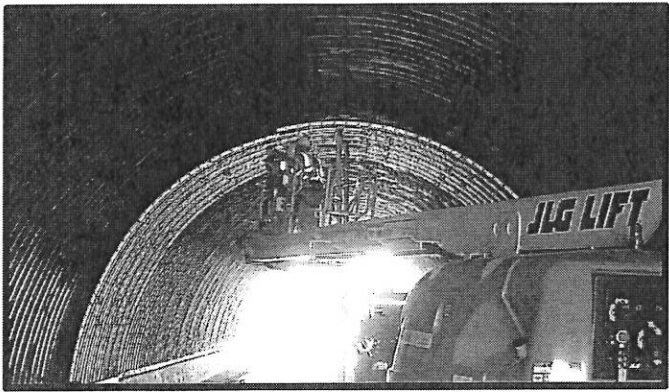

PHOTOGRAPH 7

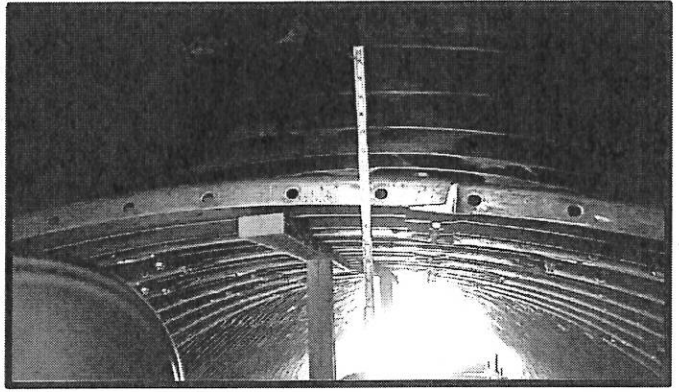

PHOTOGRAPH 8

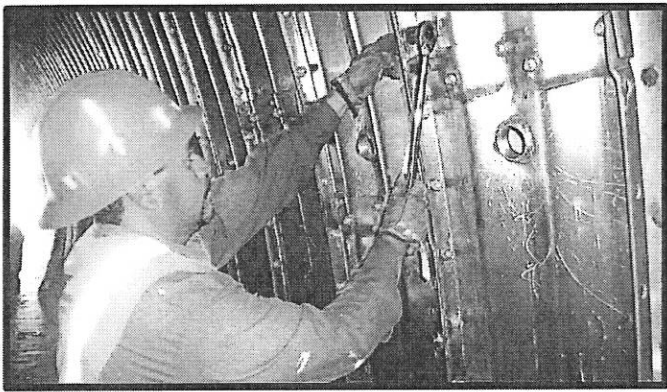

PHOTOGRAPH 9



PHOTOGRAPH 10

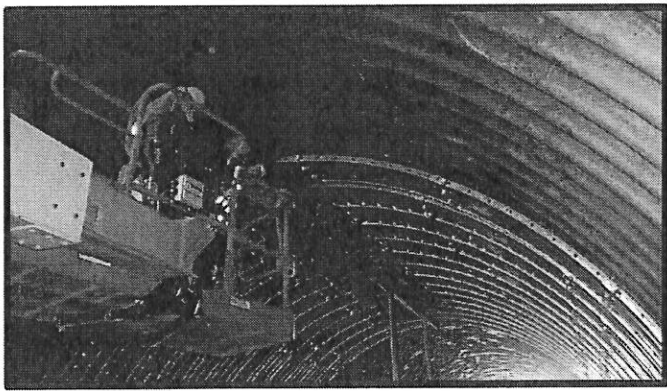

PHOTOGRAPH 11

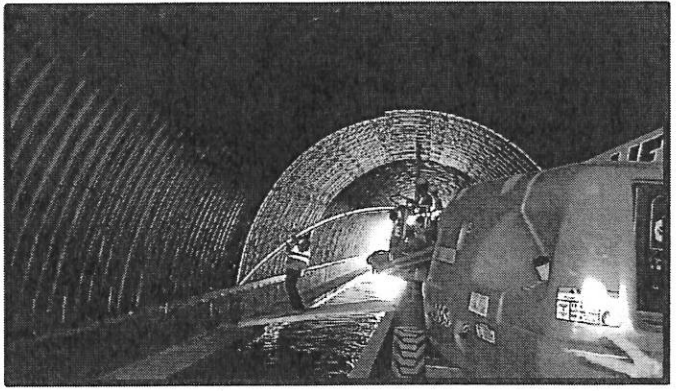

PHOTOGRAPH 12

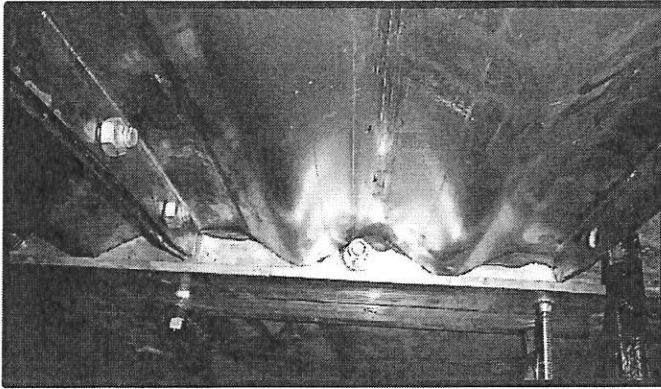

PHOTOGRAPH 13

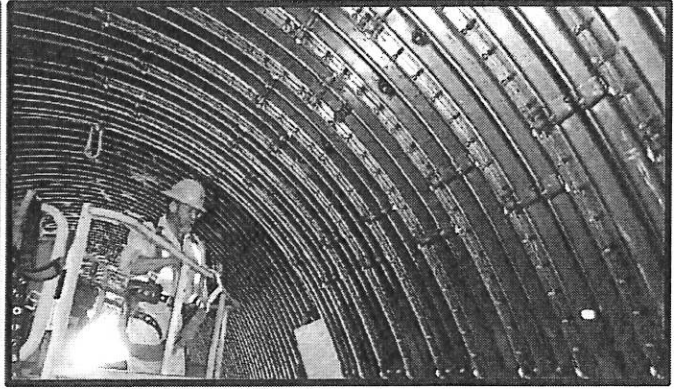

PHOTOGRAPH 14

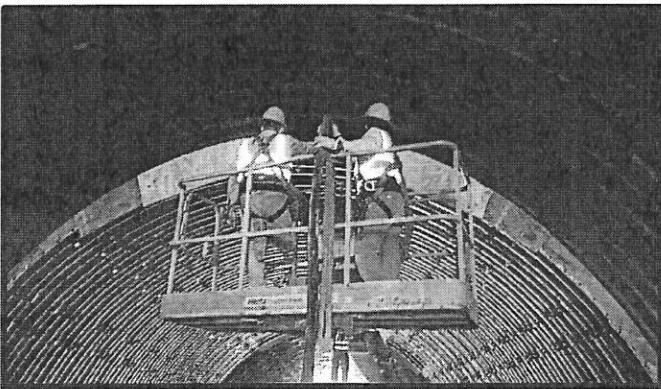

PHOTOGRAPH 15

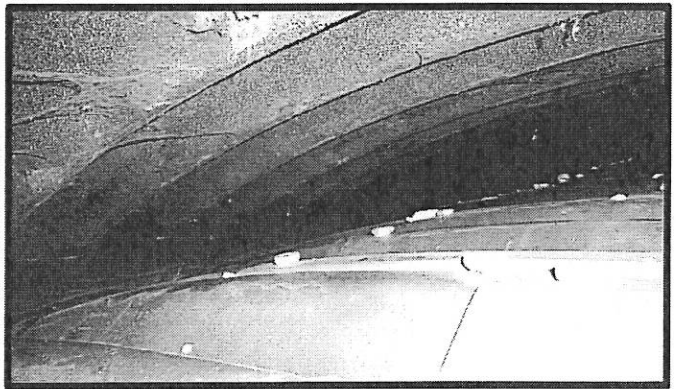

PHOTOGRAPH 16

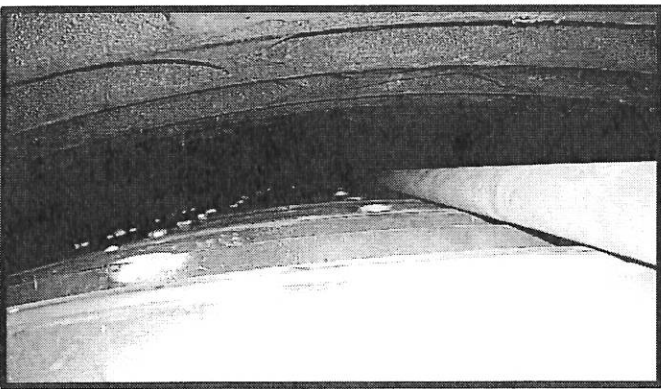

PHOTOGRAPH 17

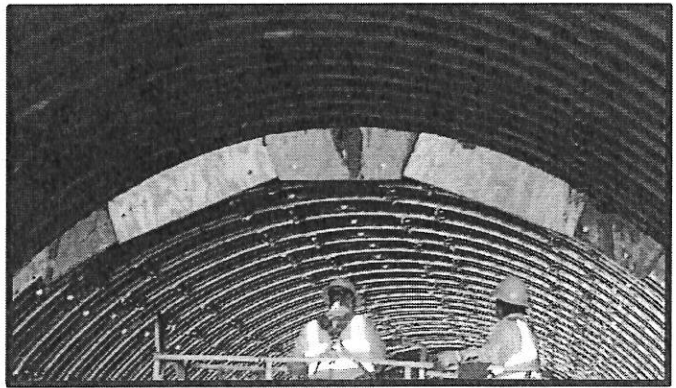

PHOTOGRAPH 18

APPENDIX C

SHAPE MEASUREMENTS

ALSP SRA; McCOLL Rd, McALLEN, TX

Sta.: 3+00



Client: CONTECH ENGINEERED SOLUTIONS, LLC

DATE: 11/10/14

Project No.: CBC-16842

Sections plotted facing Southeast

Pipe: LINER PLATE RELINE for Aluminum Structural
Plate Single Radius Arch 24'-0" Span x 12'-0" Rise

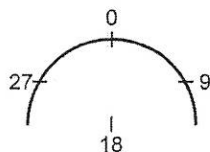
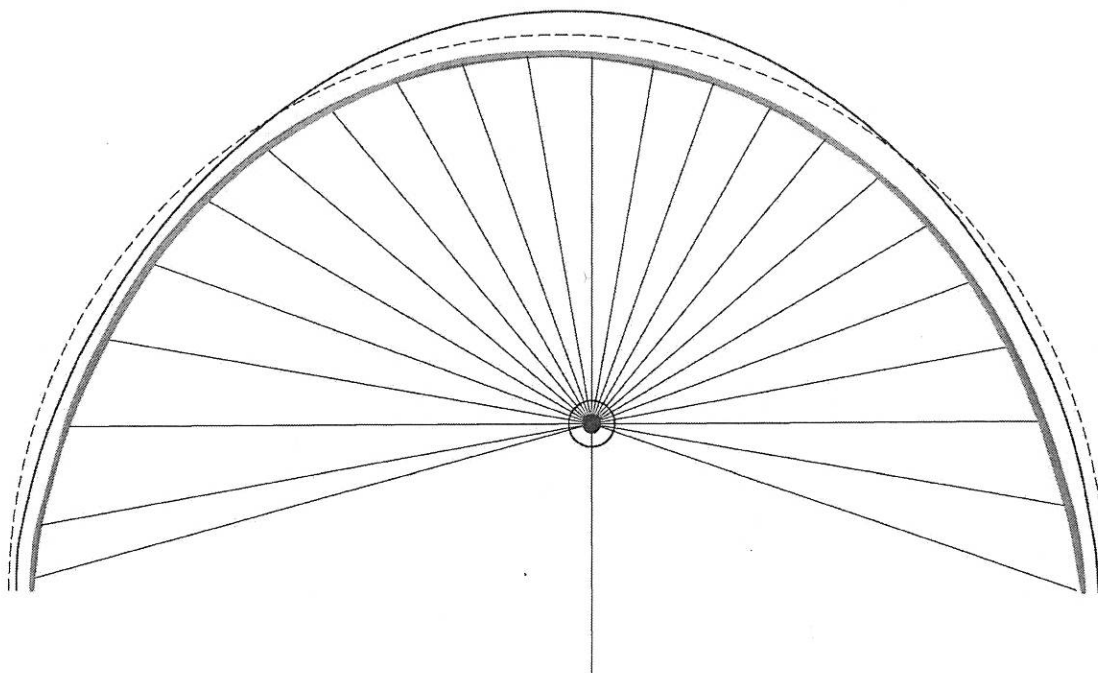

- = THEORETICAL SHAPE
- - - - - = PREVIOUS ARCH SHAPE MEASURED (4/28/14)
- _____ = ARCH SHAPE PRIOR TO LINER INSTALLATION (10/26/14)
- ===== = LINER INSTALLATION PRIOR TO GROUTING (11/3/14)
- ===== = LINER INSTALLATION AFTER GROUTING (11/10/14)

ACTUAL MEASUREMENTS (ft.)

0	8.17	9	10.01	18	5.60	27	11.66
1	8.09	10	10.73	19	0.00	28	10.97
2	8.07	11	0.00	20	0.00	29	10.42
3	8.12	12	0.00	21	0.00	30	9.93
4	8.23	13	0.00	22	0.00	31	9.48
5	8.42	14	0.00	23	0.00	32	9.07
6	8.68	15	0.00	24	0.00	33	8.78
7	9.02	16	0.00	25	0.00	34	8.55
8	9.45	17	0.00	26	12.47	35	8.31

Comments: (Description of any Tears, Leakage, Gaskets, Sediment, Bulges, Flat areas, Etc. Photograph if applicable)

ALSP SRA; McCOLL Rd, McALLEN, TX

Sta.: 3+08



Client: CONTECH ENGINEERED SOLUTIONS, LLC
 Project No.: CBC-16842
 Pipe: LINER PLATE RELINE for Aluminum Structural
 Plate Single Radius Arch 24'-0" Span x 12'-0" Rise

DATE: 11/10/14
 Sections plotted facing Southeast

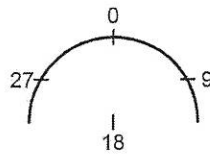
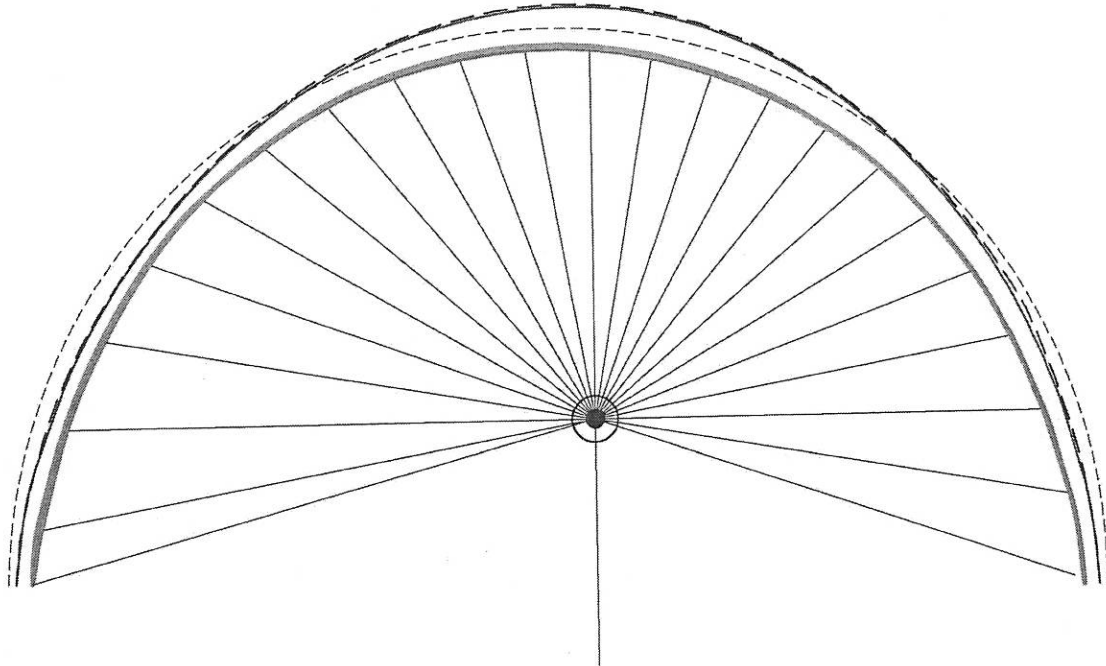

- = THEORETICAL SHAPE
- = PREVIOUS ARCH SHAPE MEASURED (4/28/14)
- = ARCH SHAPE PRIOR TO LINER INSTALLATION (10/26/14)
- = LINER INSTALLATION PRIOR TO GROUTING (11/3/14)
- = LINER INSTALLATION AFTER GROUTING (11/10/14)

ACTUAL MEASUREMENTS (ft.)

0	8.23	9	9.99	18	5.49	27	11.75
1	8.13	10	10.71	19	0.00	28	11.08
2	8.10	11	0.00	20	0.00	29	10.53
3	8.15	12	0.00	21	0.00	30	10.03
4	8.25	13	0.00	22	0.00	31	9.56
5	8.44	14	0.00	23	0.00	32	9.19
6	8.67	15	0.00	24	0.00	33	8.87
7	9.02	16	0.00	25	0.00	34	8.60
8	9.44	17	0.00	26	12.53	35	8.39

Comments: (Description of any Tears, Leakage, Gaskets, Sediment, Bulges, Flat areas, Etc. Photograph if applicable)

ALSP SRA; McCOLL Rd, McALLEN, TX

Sta.: 3+16



Client: CONTECH ENGINEERED SOLUTIONS, LLC

DATE: 11/10/14

Project No.: CBC-16842

Sections plotted facing Southeast

Pipe: LINER PLATE RELINE for Aluminum Structural
Plate Single Radius Arch 24'-0" Span x 12'-0" Rise

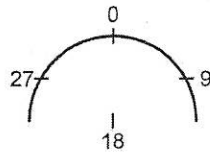
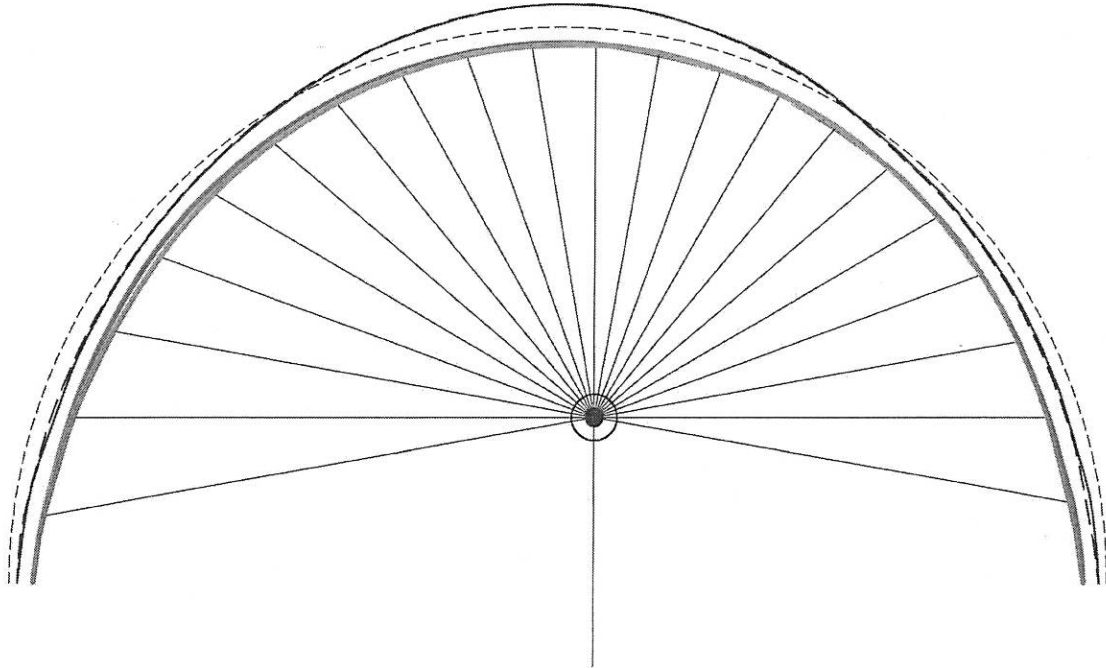

- = THEORETICAL SHAPE
- = PREVIOUS ARCH SHAPE MEASURED (4/28/14)
- = ARCH SHAPE PRIOR TO LINER INSTALLATION (10/26/14)
- = LINER INSTALLATION PRIOR TO GROUTING (11/3/14)
- = LINER INSTALLATION AFTER GROUTING (11/10/14)

ACTUAL MEASUREMENTS (ft.)

0	8.23	9	10.10	18	5.56	27	11.59
1	8.18	10	10.75	19	0.00	28	10.88
2	8.17	11	0.00	20	0.00	29	10.32
3	8.24	12	0.00	21	0.00	30	9.85
4	8.38	13	0.00	22	0.00	31	9.41
5	8.56	14	0.00	23	0.00	32	9.05
6	8.84	15	0.00	24	0.00	33	8.75
7	9.18	16	0.00	25	0.00	34	8.51
8	9.58	17	0.00	26	12.42	35	8.32

Comments: (Description of any Tears, Leakage, Gaskets, Sediment, Bulges, Flat areas, Etc. Photograph if applicable)

ALSP SRA; McCOLL Rd, McALLEN, TX

Sta.: 3+22



Client: CONTECH ENGINEERED SOLUTIONS, LLC

DATE: 11/10/14

Project No.: CBC-16842

Sections plotted facing Southeast

Pipe: LINER PLATE RELINE for Aluminum Structural
Plate Single Radius Arch 24'-0" Span x 12'-0" Rise

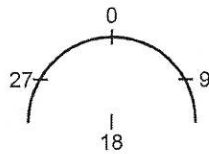
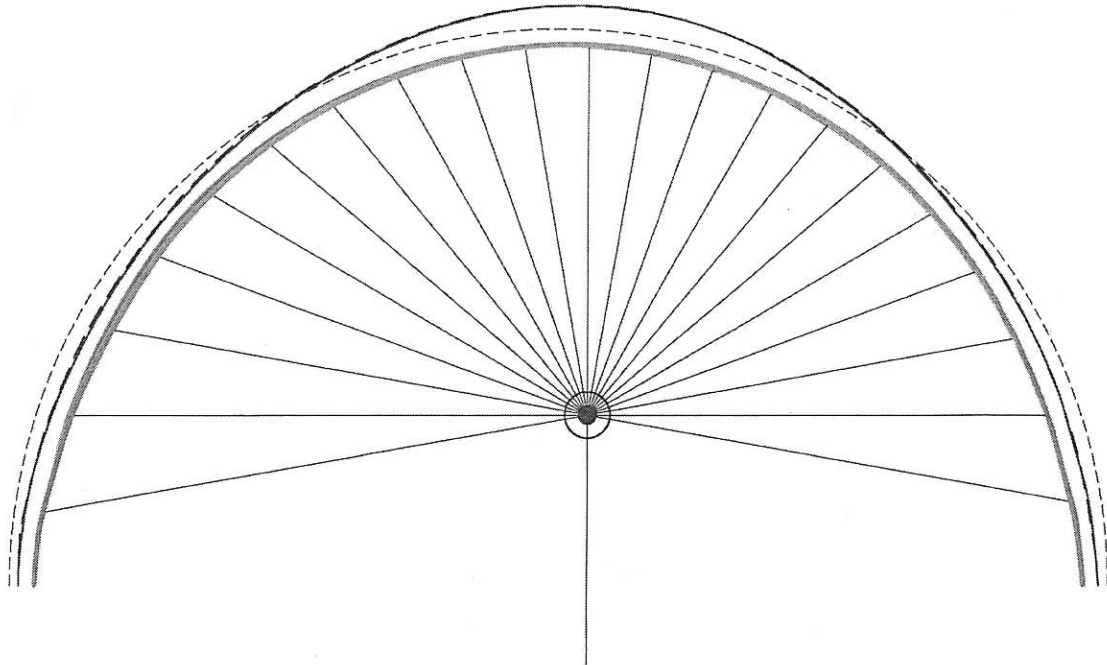

- = THEORETICAL SHAPE
- = PREVIOUS ARCH SHAPE MEASURED (4/28/14)
- = ARCH SHAPE PRIOR TO LINER INSTALLATION (10/26/14)
- = LINER INSTALLATION PRIOR TO GROUTING (11/3/14)
- = LINER INSTALLATION AFTER GROUTING (11/10/14)

ACTUAL MEASUREMENTS (ft.)

0	8.18	9	10.26	18	5.58	27	11.46
1	8.15	10	10.94	19	0.00	28	10.75
2	8.17	11	0.00	20	0.00	29	10.20
3	8.25	12	0.00	21	0.00	30	9.72
4	8.41	13	0.00	22	0.00	31	9.28
5	8.63	14	0.00	23	0.00	32	8.92
6	8.91	15	0.00	24	0.00	33	8.63
7	9.27	16	0.00	25	0.00	34	8.41
8	9.70	17	0.00	26	12.27	35	8.26

Comments: (Description of any Tears, Leakage, Gaskets, Sediment, Bulges, Flat areas, Etc. Photograph if applicable)

ALSP SRA; McCOLL Rd, McALLEN, TX

Sta.: 3+30



Client: CONTECH ENGINEERED SOLUTIONS, LLC

DATE: 11/10/14

Project No.: CBC-16842

Sections plotted facing Southeast

Pipe: LINER PLATE RELINE for Aluminum Structural
Plate Single Radius Arch 24'-0" Span x 12'-0" Rise

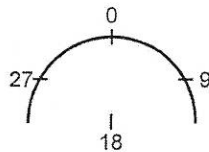
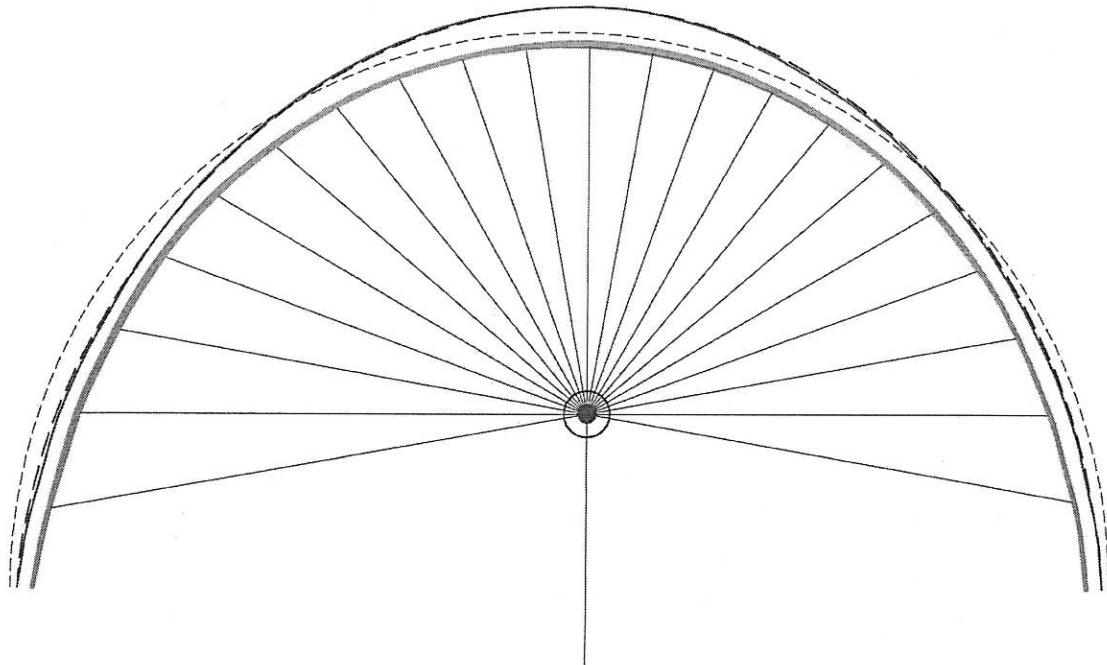

- = THEORETICAL SHAPE
- - - - - = PREVIOUS ARCH SHAPE MEASURED (4/28/14)
- _____ = ARCH SHAPE PRIOR TO LINER INSTALLATION (10/26/14)
- ===== = LINER INSTALLATION PRIOR TO GROUTING (11/3/14)
- ===== = LINER INSTALLATION AFTER GROUTING (11/10/14)

ACTUAL MEASUREMENTS (ft.)

0	8.20	9	10.31	18	5.59	27	11.29
1	8.17	10	11.02	19	0.00	28	10.61
2	8.21	11	0.00	20	0.00	29	10.07
3	8.29	12	0.00	21	0.00	30	9.60
4	8.44	13	0.00	22	0.00	31	9.17
5	8.66	14	0.00	23	0.00	32	8.84
6	8.95	15	0.00	24	0.00	33	8.58
7	9.31	16	0.00	25	0.00	34	8.37
8	9.75	17	0.00	26	12.09	35	8.25

Comments: (Description of any Tears, Leakage, Gaskets, Sediment, Bulges, Flat areas, Etc. Photograph if applicable)

16842D Vertical Rise Measurements

Station	Initial	Pour Number		Pour Number	Pour Number	Pour Number	Pour Number	
		1	2				1	2
Date	31-Oct	3-Nov	3-Nov	4-Nov*	5-Nov	5-Nov	6-Nov	10-Nov
3+00	12.31	12.31	12.31	12.32	12.32	12.32	12.32	12.32
3+08	12.35	12.34	12.36	12.34	12.35	12.35	12.35	12.35
3+16	12.36	12.36	12.39	12.37	12.37	12.37	12.37	12.37
3+22	12.34	12.35	12.36	12.35	12.36	12.37	12.36	12.37
3+30	12.36	12.36	12.36	12.36	12.36	12.36	12.37	12.36

* Only one pour today due to equipment failure

HIDALGO COUNTY PRECINCT NO. 2 MISSION INLET ARCH CULVERT ALUMINUM LINER PLATE RELINE 2014 RECORD DRAWINGS

INDEX OF SHEETS

NO.	DESCRIPTION
1	- TITLE SHEET
2	- CULVERT LAYOUT

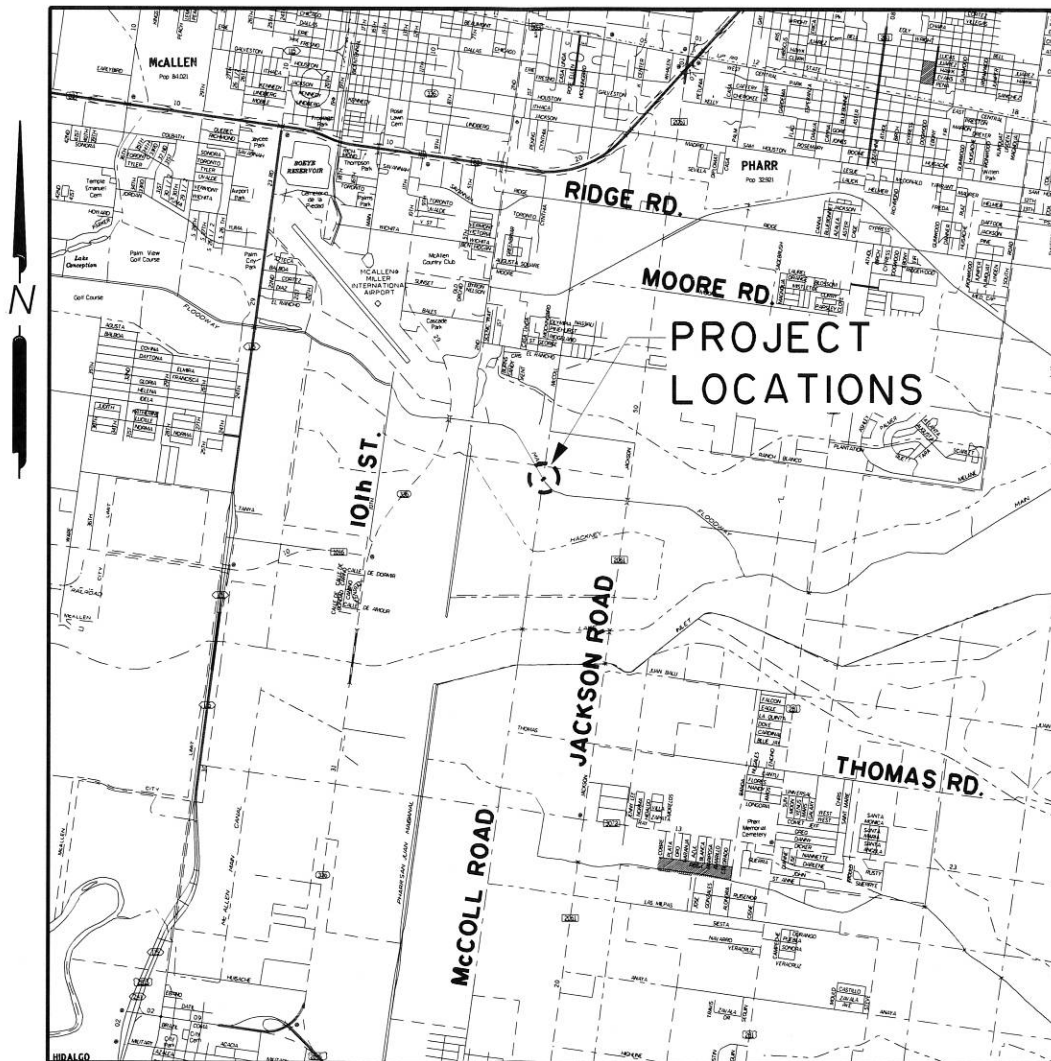

LOCATION MAP

HIDALGO COUNTY DRAINAGE DISTRICT No.1 BOARD OF DIRECTORS

CHAIRMAN
BOARD MEMBER
BOARD MEMBER
BOARD MEMBER
BOARD MEMBER
DISTRICT MANAGER

RAMON GARCIA
A.C. CUELLAR, JR.
HECTOR "TITO" PALACIOS
JOE M. FLORES
JOSEPH PALACIOS
GODFREY GARZA



THE SEAL APPEARING ON THIS DOCUMENT WAS AUTHORIZED BY HERNAN A. LUGO, P.E. 108728

DATE: 12-22-2014

ALTERATION OF A SEALED DOCUMENT WITHOUT PROPER NOTIFICATION TO THE RESPONSIBLE ENGINEER IS AN OFFENSE UNDER THE TEXAS ENGINEERING PRACTICE LAW.

R. Gutierrez Professional Engineers & Land Surveyors
 Engineering Corporation
 130 E. PARK AVENUE • PHARR, TEXAS 78577
 (TEL) 956 782-2557 • (FAX) 956 782-2558

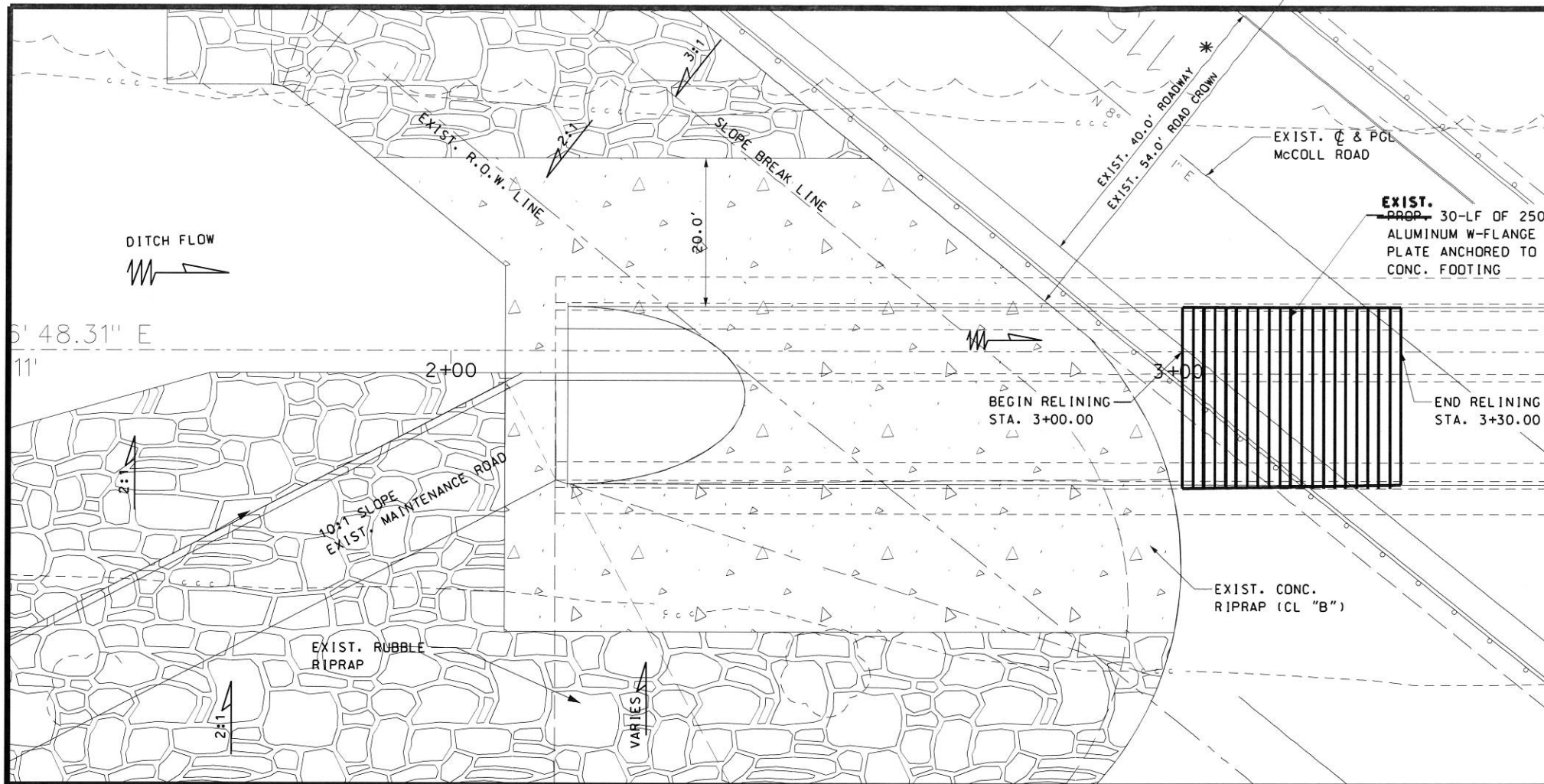

SCALE
 HORZ. 1"=20'
 VERT. 1"=10'

LEGEND

- DITCH FLOW DIRECTION
- CONC. RIPRAP
- PROP. FILL
- GRAVEL BEDDING
- RUBBLE RIPRAP

* TO BE CONSTRUCTED BY OTHERS AFTER COMPLETION OF THIS PROJECT

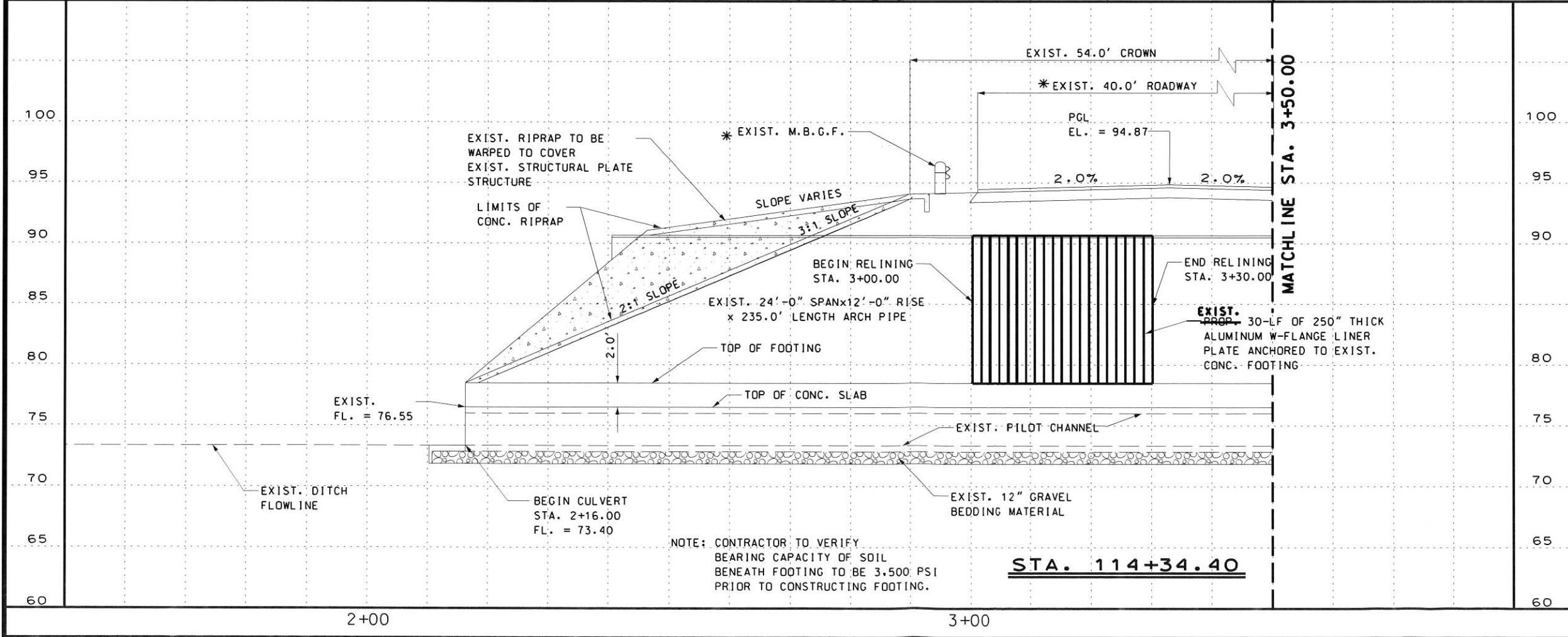

THE SEAL APPEARING ON THIS DOCUMENT WAS AUTHORIZED BY HERNAN A. LUGO, P.E. 108728

DATE: 12-22-2014

ALTERATION OF A SEALED DOCUMENT WITHOUT PROPER NOTIFICATION TO THE RESPONSIBLE ENGINEER IS AN OFFENSE UNDER THE TEXAS ENGINEERING PRACTICE LAW.

R. Gutierrez Engineering Corporation Professional Engineers & Land Surveyors
 130 E. PARK AVENUE • PHARR, TEXAS 78577
 (TEL) 956 782-2557 • (FAX) 956 782-2558

Texas Department of Transportation
 © 2010 by TxDOT

MISSION INLET ARCH CULVERT ALUMINUM LINER PLATE RELINE RECORD DRAWING

DESIGNED: MH	FED. RD DIV. No.	STATE	FEDERAL AID PROJECT No.	HIGHWAY No.
CHECKED: JH	6	TEXAS	XXXXXXXX	McCOLL RD.
DRAWN: JR	STATE DISTRICT	COUNTY	CONTROL No.	SECTION No.
CHECKED: RG	PHARR	HIDALGO	0921	02
			JOB No.	SHEET No.
			938	2

NOTE: CONTRACTOR TO VERIFY BEARING CAPACITY OF SOIL BENEATH FOOTING TO BE 3,500 PSI PRIOR TO CONSTRUCTING FOOTING.

STA. 114+34.40

\$FILES

R. Gutierrez Engineering Corporation

Transmittal Form

TO: Claudette Guerrero

Hidalgo County Drainage District 1

FROM: Javier Gutierrez

 SUBJECT: Mission Inlet Arch Culvert - Aluminum Liner Plate Re-Line

 PROJECT NO.: ENG14.007

 DATE: December 22, 2014

WE ARE SENDING YOU ATTACHED UNDER SEPARATE COVER VIA Hand Delivery THE FOLLOWING ITEMS:

BLUEPRINTS PLANS SHOP DRAWINGS CD
 CHANGE ORDER SAMPLES PAYMENT REQUEST OTHER:
 BID TABULATION CONTRACT DOCUMENTS RECORD DRAWINGS 3 1/2" DISKETTE

QUANTITY / SETS	DATED	ITEM DESCRIPTION
1		Payment Request - RETAINAGE with Backup Documents
1		Engineering Report from Foremost Paving

THESE ARE TRANSMITTED AS CHECKED BELOW:

FOR BIDS DUE APPROVED AS NOTED FOR YOUR RECORDS
 FOR APPROVAL APPROVED AS SUBMITTED FOR YOUR ACKNOWLEDGEMENT
 FOR YOUR USE RETURN FOR CORRECTIONS RESUBMIT FOR APPORVAL
 AS REQUESTED FOR FURTHER PROCESSING ON LOAN
 FOR REVIEW AND COMMENT FOR SIGNATURE OTHER

RECEIVED
 HIDALGO COUNTY
 DRAINAGE DISTRICT #1

DEC 22 2014

2:15 AM PM

BY: Joey Guerra

COMMENTS: _____

Copy Distribution: file Received by: _____

HIDALGO COUNTY DRAINAGE DISTRICT NUMBER ONE

902 NORTH DOOLITTLE

EDINBURG, TEXAS 78542

(956) 292-7080

FAX (956) 292-7089



GODFREY GARZA, JR.
MANAGER

INVOICE PROCESSING CHECKLIST

Date Received: 12/22/2014

Engineer/Firm Name: Rojas Construction & Paving

Project Name/Number: FM495 Drain- Wisconsin Road Crossing

Invoice No: PMT # 1

Logged in and Scanned 221PM 12/23 By: R. Arce Forwarded to: Joey Garza

Engineer	Name	Date	Comment
Scope of work reviewed			

Accounting	Name	Date	Comment
Encumbrance			
Purchase Order Attached			
Audit			
Final Approval for Agenda			

	Name	Date	Comment
Placed on Agenda			

Additional Comments: _____

DEC 22 2014

2:15 AM (PM)

APPLICATION FOR PMT #1

BY: Joey Garza

To: HIDALGO COUNTY DRAINAGE DISTRICT NO. 1 (OWNER)
 From: Rojas Construction & Paving (CONTRACTOR)
 Contract: HCDD1-13-021-04-29B
 Project: FM495 Drain - Wisconsin Road Crossing
 OWNER's Contract No. HCDD1-13-021-04-29B ENGINEER's Project No.: ENG99.003
 For Work accomplished through the date of: November 30, 2014

1. Original Contract Price:	\$ 201,326.50
2. Net change by Change Orders and Written Agreements (+ or -):	\$ -
3. Current Contract Price (1 plus 2):	\$ 201,326.50
4. Total completed and stored to date: 78.56%	\$ 158,164.00
5. Retainage (per Agreement):	
<u>5% of completed Work:</u>	<u>\$ 7,908.20</u>
<u>5% of stored material:</u>	<u>\$ -</u>
Total Retainage:	\$ 7,908.20
6. Total completed and stored to date less retainage (4 minus 5):	\$ 150,255.80
7. Less previous Application for Payments:	\$ -
8. Balance to Finish:	\$ 43,162.50
9. AMOUNT DUE THIS APPLICATION (6 MINUS 7):	\$ 150,255.80

Accompanying Documentation:

CONTRACTOR'S Certification:

The undersigned CONTRACTOR certifies that (1) all previous progress payments received from OWNER on account of Work done under the Contract referred to above have been applied on account to discharge CONTRACTOR's legitimate obligations incurred in connection with Work covered by prior Applications for Payment numbered 1 through PMT #1 inclusive; (2) title of all Work, materials and equipment incorporated in said Work or otherwise listed in or covered by this Application for Payment will pass to OWNER at time of payment free and clear of all Liens, security interests and encumbrances (except such as are covered by a Bond acceptable to OWNER indemnifying OWNER against any such Lien, security interest or encumbrance); and (3) all Work covered by this Application for Payment is in accordance with the Contract Documents and not defective.

Dated December 8, 2014

Rojas Construction & Paving
CONTRACTOR

By: _____

State of Texas

County of Cameron

Subscribed and sworn to before me this 8th day of December

[Signature]
Notary Public

My Commission expires: May 16, 2018

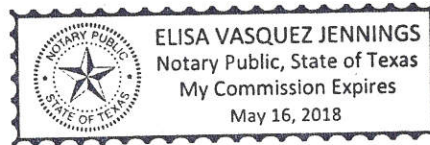

Payment of the above AMOUNT DUE THIS APPLICATION is recommended.

Dated 12-9-2014

R. GUTIERREZ ENGINEERING CORPORATION
ENGINEER

By: Rain [Signature], P.E.

Schedule of Values

Contractor Name: Rojas Construction & Paving
 Starting Date: October 6, 2014
 Project Ending Date: December 4, 2014
 Retainage Percent: 5%

Application: PMT #1
 Application Date: December 8, 2014
 Period To: November 30, 2014
 Engineer Firm: R. Gutierrez Eng. Corp.

Summary													
Contract Number	Description	Original Schedule Value	Application #1	Retainage for App #1	Payment for Application #1	Final Application	Retainage for Final App	Payment for Final Application	Total Completed to Date	Retainage to Date	Total Completed Less Retainage	Previous Payments	Balance To Finish
HCDD1-13-021-04-29B	FM495 Drain - Wisconsin Road Crossing	\$ 201,326.50	\$ 158,164.00	\$ 7,908.20	\$ 150,255.80	\$ -	\$ -	\$ -	\$ 158,164.00	\$ 7,908.20	\$ 150,255.80	\$ -	\$ 43,162.50
TOTALS:		\$ 201,326.50	\$ 158,164.00	\$ 7,908.20	\$ 150,255.80	\$ -	\$ -	\$ -	\$ 158,164.00	\$ 7,908.20	\$ 150,255.80	\$ -	\$ 43,162.50

Contractor Name: Rojas Construction & Paving
 Starting Date: October 6, 2014
 Project Ending Date: December 4, 2014
 Engineer's / County Project Desc: FM495 Drain - Wisconsin Road Crossing

Application: PMT #1
 Application Date: December 8, 2014
 Period To: November 30, 2014
 Engineer's / County Project No.: ENG99.003

No.	Item Code	Description	Unit	Original Schedule Value			Application #1			Final Application			Total to Date	Balance To Finish	
				Original Rates	Quan	Dollars	Monthly Quan	QTY to Date	Item Cost (Monthly)	Monthly Quan	QTY to Date	Item Cost (Monthly)		Quan	Dollars
1	402	Channel Excavation	CY	\$ 7.00	738.00	\$ 5,166.00		-	\$ -		-	\$ -		738.00	\$ 5,166.00
2	432	Embankment (Final) (Dens. Cont.) (Ty D)	CY	\$ 12.00	3,227.00	\$ 38,724.00	3,227.00	3,227.00	\$ 38,724.00		3,227.00	\$ -	\$ 38,724.00	0.00	\$ -
3	464	Cellulose Fiber Mulch Seeding	SY	\$ 1.25	1,742.00	\$ 2,177.50		-	\$ -		-	\$ -	\$ -	1,742.00	\$ 2,177.50
4	464	Vegetative Watering	MG	\$ 100.00	19.50	\$ 1,950.00		-	\$ -		-	\$ -	\$ -	19.50	\$ 1,950.00
5	464	Asphalt Conc. Pavement Overlay (1-1/2-IN)	SY	\$ 9.00	228.00	\$ 2,052.00		-	\$ -		-	\$ -	\$ -	228.00	\$ 2,052.00
6	465	Cut & Restore Pavement	SY	\$ 20.00	65.00	\$ 1,300.00		-	\$ -		-	\$ -	\$ -	65.00	\$ 1,300.00
7	465	Cement Stablized Backfill	CY	\$ 40.00	284.00	\$ 11,360.00	284.00	284.00	\$ 11,360.00		284.00	\$ -	\$ 11,360.00	0.00	\$ -
8	465	Roadside Ditch Excavation	CY	\$ 5.00	290.00	\$ 1,450.00		-	\$ -		-	\$ -	\$ -	290.00	\$ 1,450.00
9	465	Trench Excavation Protection	LF	\$ 1.00	456.00	\$ 456.00	456.00	456.00	\$ 456.00		456.00	\$ -	\$ 456.00	0.00	\$ -
10	467	Concrete Riprap (CL B) (4-IN)	CY	\$ 350.00	60.00	\$ 21,000.00		-	\$ -		-	\$ -	\$ -	60.00	\$ 21,000.00
11	529	Conc. Box Culvert (8'x8')	LF	\$ 500.00	144.00	\$ 72,000.00	144.00	144.00	\$ 72,000.00		144.00	\$ -	\$ 72,000.00	0.00	\$ -
12	529	Drop Inlet (Complete) (Grate Inlet) (TY C)	EA	\$ 2,500.00	2.00	\$ 5,000.00	2.00	2.00	\$ 5,000.00		2.00	\$ -	\$ 5,000.00	0.00	\$ -
13	530	PVC Pipe (15-IN) (Sch 40)	LF	\$ 30.00	85.00	\$ 2,550.00		-	\$ -		-	\$ -	\$ -	85.00	\$ 2,550.00
14	531	PVC Pipe (18-IN) (Sch 40)	LF	\$ 54.00	122.00	\$ 6,588.00	122.00	122.00	\$ 6,588.00		122.00	\$ -	\$ 6,588.00	0.00	\$ -
15	532	Remove Structure (36-IN Diversion Pipe)	LF	\$ 5.00	417.00	\$ 2,085.00		-	\$ -		-	\$ -	\$ -	417.00	\$ 2,085.00
16	533	Barricades, Signs and Traffic Handling	MO	\$ -	2.00	\$ -		-	\$ -		-	\$ -	\$ -	2.00	\$ -
17	534	Construction Exit (Ty II) (Install)	SY	\$ 4.00	156.00	\$ 624.00		-	\$ -		-	\$ -	\$ -	156.00	\$ 624.00
18	535	Construction Exit (Ty II) (Remove)	SY	\$ 4.00	156.00	\$ 624.00		-	\$ -		-	\$ -	\$ -	156.00	\$ 624.00
19	536	Temporary Sediment Control Fence	LF	\$ 3.00	1,234.00	\$ 3,702.00	812.00	812.00	\$ 2,436.00		812.00	\$ -	\$ 2,436.00	422.00	\$ 1,266.00
20	537	Thermoplastic Pipe (36-IN)	LF	\$ 54.00	417.00	\$ 22,518.00	400.00	400.00	\$ 21,600.00		400.00	\$ -	\$ 21,600.00	17.00	\$ 918.00
Total						\$ 201,326.50			\$ 158,164.00			\$ -			\$ 43,162.50

Printed Name:

Javier Gutierrez

Date:

12/9/2014

Signature:



Construction & Paving



Equipment Rental & Sales

ROJAS CONSTRUCTION & PAVING

Tel: (956) 787 8778

www.rojasheavy.net

240 Frontage Rd Alamo, TX 78516

Mr. Javier Gutierrez
R. Gutierrez Engineering Corporation
130 E. Park
Pharr, TX 78577
956.782.2557

RE: FM495 DRAIN WISCONSIN ROAD CROSSING
Contract No.: HCDD1-13-022-04-29B

Mr. Gutierrez:

The following is a list of supplier's used in the above mentioned project, per your request:

L&R Precast Concrete Works Inc.
3807 Bentsen Palm Drive
Mission, TX 78574-8200
956.583.6293

CAPA dba Rio Valley Pipe LLC
7301 W. Expressway 83
Mission, TX 78572
956.580.2502

Aguaworks
2807 N. Central Ave.
Brownsville, TX 78526
956.831.2500

Respectfully,

Elisa Vasquez

Contract Time Statement

FM495 Drain - Wisconsin Road Crossing

PAY REQUEST 1 CONTRACTOR ROJAS HEAVY EQUIPMENT, LLC dba ROJAS CONSTRUCTION & PAVING

PROJECT NO. HCDD1-13-022-04-29B City Alamo, Texas DATE WORK BEGAN 10/6/2014

TIME COMPUTED FROM 10/6/2014 DATE WORK COMPLETED _____

MONTH	DATE OR DAYS	WORKING DAYS	DAYS CREDITED	DESCRIPTION
July	7			Pre-Construction Meeting & Notice to Proceed Issued
	10			Notice to Suspend Contract Time #1 issued
August	25			Notice to Suspend Contract Time #2 issued
October	6	1		Letter to Resume Work sent to contractor with time starting on October 6
	7	1		Not working on project
	8	1		Not working on project
	9	1		Not working on project
	10	1		Not working on project
	11	1	1	Rain / Too wet to Work - No work done - Weekend
	12	1	1	Rain / Too wet to Work - No work done - Weekend
	13	1	1	Rain / Too wet to work
	14	1	1	Rain / Too wet to work
	15	1		Not working on project
	16	1		Not working on project
	17	1		Contractor moved excavator to project
	18	1		No work done - Weekend
	19	1		No work done - Weekend
	20	1		Installed silt fence
	21	1	1	Continue install silt fence and Rain out
	22	1	1	Rain / Too wet to work
	23	1		Not working on project
	24	1		Installed traffic control signs
	25	1		No work done - Weekend
	26	1		No work done - Weekend
	27	1		Not working on project
	28	1		Not working on project
	29	1		Not working on project
	30	1		Not working on project
	31	1		Not working on project
TOTALS		26	6	

NO. OF CONTRACT CALANDER DAYS 60 NO. CALANDER DAYS CHARGED TO DATE 26

ASSESSED LIQUIDATED DAMAGES: NO. DAYS 0 PER DAY \$ _____ TOTAL _____

CERTIFIED AS CORRECT (ONE COPY HAS BEEN GIVEN TO THE CONTRACTOR) _____
Ram P.E.
PROJECT ENGINEER

INSTRUCTIONS: PROJECT IDENTIFICATION SHOULD COVER CONTRACT. TIME CREDITED AND REASONS THEREFORE MUST CONFORM TO PROVISIONS OF CONTRACT. NO HOLIDAY CREDIT ALLOWED FOR DAYS PRECEDING OR FOLLOWING LEGAL HOLIDAYS. TIME SUSPENDED AND RESUMED MUST BE SUPPORTED BY COPY EACH OF LETTERS TO CONTRACTOR DATED ON OR BEFORE EFFECTIVE DATES. TIME EXTENSION MUST BE INDICATED AND REFERENCED TO RELATED PROVISION OF CONTRACT. SEE BOOKLET OF INSTRUCTIONS, CONSTRUCTION ESTIMATES DATED SEPTEMBER 1, 1956

Contract Time Statement

FM495 Drain - Wisconsin Road Crossing

PAY REQUEST 1 CONTRACTOR ROJAS HEAVY EQUIPMENT, LLC dba ROJAS CONSTRUCTION & PAVING

PROJECT NO. HCDD1-13-022-04-29B City Alamo, Texas DATE WORK BEGAN 10/6/2014

TIME COMPUTED FROM 10/6/2014 DATE WORK COMPLETED _____

MONTH	DATE OR DAYS	WORKING DAYS	DAYS CREDITED	DESCRIPTION
November	1	1		No work done - Weekend
	2	1		No work done - Weekend
	3	1		Not working on project
	4	1		Work on traffic control signs
	5	1	1	Rain / Too wet to work
	6	1	1	Rain / Too wet to work
	7	1	1	Rain / Too wet to work
	8	1	1	Rain / Too wet to work
	9	1	1	Rain / Too wet to work
	10	1	1	Rain / Too wet to work
	11	1		Works on excavation & install 36" SDS pipe bypass
	12	1	1	Works on excavation & install 36" SDS pipe bypass - Rain out @ 11AM
	13	1	1	Rain / Too wet to work
	14	1	1	Rain / Too wet to work
	15	1		Weekend - Work on excavation and install of 36" SDS bypass pipe
	16	1	1	Weekend - Rain / Too wet to work
	17	1		Work on excavation,berms, compation and install of 36" SDS bypass pipe
	18	1		Receive & unload 8x8 boxes, test compaction, 36" SDS, backfill
	19	1		Work on excavation & install 8x8 boxes
	20	1		Work on excavation & install 8x8 boxes
	21	1	1	Work on excavation & install 8x8 boxes & Rainout
	22	1	1	Weekend - Rain / Too wet to work
	23	1	1	Weekend - Rain / Too wet to work
	24	1	1	Rain / Too wet to work
	25	1		Work on dewatering, mix & install cement stab sand for 8x8 boxes
	26	1		Work on backfill 8x8 boxes
	27	1		Thanksgiving Holiday
	28	1		No work done
	29	1		No work done - Weekend
	30	1		No work done - Weekend
TOTALS		30	14	

NO. OF CONTRACT CALANDER DAYS 60 NO. CALANDER DAYS CHARGED TO DATE 56

ASSESSED LIQUIDATED DAMAGES: NO. DAYS 0 PER DAY \$ _____ TOTAL _____

CERTIFIED AS CORRECT (ONE COPY HAS BEEN GIVEN TO THE CONTRACTOR) Rain [Signature], P.E.
PROJECT ENGINEER

INSTRUCTIONS: PROJECT IDENTIFICATION SHOULD COVER CONTRACT. TIME CREDITED AND REASONS THEREFORE MUST CONFORM TO PROVISIONS OF CONTRACT. NO HOLIDAY CREDIT ALLOWED FOR DAYS PRECEDING OR FOLLOWING LEGAL HOLIDAYS. TIME SUSPENDED AND RESUMED MUST BE SUPPORTED BY COPY EACH OF LETTERS TO CONTRACTOR DATED ON OR BEFORE EFFECTIVE DATES. TIME EXTENSION MUST BE INDICATED AND REFERENCED TO RELATED PROVISION OF CONTRACT. SEE BOOKLET OF INSTRUCTIONS, CONSTRUCTION ESTIMATES DATED SEPTEMBER 1, 1956



NAME OF CONTRACTOR OR SUBCONTRACTOR
 ROJAS CONSTRUCTION & PAVING LLC
 ADDRESS 240 FRONTAGE RD ALAMO, TX 78516
 PROJECT AND LOCATION FM495 DRAIN WISCONSIN ROAD CROSSING
 PROJECT OR CONTRACT NO. HCDD1-13-022-04-29B
 PAYROLL NO. 1 INITIAL
 OMB No.: 1235-0008
 Expires: 01/31/2015

(1) NAME AND INDIVIDUAL IDENTIFYING NUMBER (e.g., LAST FOUR DIGITS OF SOCIAL SECURITY NUMBER) OF WORKER	(2) NO. OF WITHHOLDING EXEMPTIONS	(3) WORK CLASSIFICATION	(4) DAY AND DATE							(5) TOTAL HOURS	(6) RATE OF PAY	(7) GROSS AMOUNT EARNED	(8) DEDUCTIONS				(9) NET WAGES PAID FOR WEEK
			M 10/13	T 10/14	W 10/15	TH 10/16	F 10/17	S 10/18	S 10/19				FICA	WITH- HOLDING TAX	MEDI CARE	SS	
PABLO GONZALEZ PO BOX 753 MERCEDES, TX SS # XXX-XX-9967	5	EXCAVATOR OPERATOR LESS THAN 50,000LBS						10.50		\$19.50	\$136.50	\$0.00	\$7.71	\$32.99	\$40.70	\$491.30	
ERNESTO MEDRANO 19042 RD 870 SAN BENITO, TX SS# XXX-XX-3848	2	SUPERVISION					8.00			\$18.00	\$96.00	\$34.00	\$6.96	\$29.76	\$70.72	\$409.28	

While completion of Form WH-347 is optional, it is mandatory for covered contractors and subcontractors performing work on Federally financed or assisted construction contracts to respond to the information collection contained in 29 C.F.R. §§ 3.3, 5.5(a), The Copeland Act (40 U.S.C. § 3145) contractors and subcontractors performing work on Federally financed or assisted construction contracts to "furnish weekly a statement with respect to the wages paid each employee during the preceding week." U.S. Department of Labor (DOL) regulations at 29 C.F.R. § 5.5(a)(3)(ii) require contractors to submit weekly a copy of all payrolls to the Federal agency contracting for or financing the construction project, accompanied by a signed "Statement of Compliance" indicating that the payrolls are correct and complete and that each laborer or mechanic has been paid not less than the proper Davis-Bacon prevailing wage rate for the work performed. DOL and federal contracting agencies receiving this information review the information to determine that employees have received legally required wages and fringe benefits.

Public Burden Statement

We estimate that it will take an average of 55 minutes to complete this collection, including time for reviewing instructions, searching existing data sources, gathering and maintaining the data needed, and completing and reviewing the collection of information. If you have any comments regarding these estimates or any other aspect of this collection, including suggestions for reducing this burden, send them to the Administrator, Wage and Hour Division, U.S. Department of Labor, Room S3502, 200 Constitution Avenue, N.W., Washington, D.C. 20210

(over)

Date DECEMBER 19, 2014

I, ELISA VASQUEZ _____ ADMINISTRATOR
(Name of Signatory Party) (Title)

do hereby state:

(1) That I pay or supervise the payment of the persons employed by
ROJAS CONSTRUCTION & PAVING LLC _____ on the
(Contractor or Subcontractor)

13 day of OCTOBER, 2014, and ending the 19 day of OCTOBER, 2014
(Building or Work) _____; that during the payroll period commencing on the

all persons employed on said project have been paid the full weekly wages earned, that no rebates have been or will be made either directly or indirectly to or on behalf of said

ROJAS CONSTRUCTION & PAVING LLC _____ from the full
(Contractor or Subcontractor)

weekly wages earned by any person and that no deductions have been made either directly or indirectly from the full wages earned by any person, other than permissible deductions as defined in Regulations, Part 3 (29 C.F.R. Subtitle A), issued by the Secretary of Labor under the Copeland Act, as amended (48 Stat. 948, 63 Stat. 108, 72 Stat. 967; 76 Stat. 357; 40 U.S.C. § 3145), and described below:

(2) That any payrolls otherwise under this contract required to be submitted for the above period are correct and complete; that the wage rates for laborers or mechanics contained therein are not less than the applicable wage rates contained in any wage determination incorporated into the contract; that the classifications set forth therein for each laborer or mechanic conform with the work he performed.

(3) That any apprentices employed in the above period are duly registered in a bona fide apprenticeship program registered with a State apprenticeship agency recognized by the Bureau of Apprenticeship and Training, United States Department of Labor, or if no such recognized agency exists in a State, are registered with the Bureau of Apprenticeship and Training, United States Department of Labor.

(4) That:
(a) WHERE FRINGE BENEFITS ARE PAID TO APPROVED PLANS, FUNDS, OR PROGRAMS

- in addition to the basic hourly wage rates paid to each laborer or mechanic listed in the above referenced payroll, payments of fringe benefits as listed in the contract have been or will be made to appropriate programs for the benefit of such employees, except as noted in section 4(c) below.

(b) WHERE FRINGE BENEFITS ARE PAID IN CASH

- Each laborer or mechanic listed in the above referenced payroll has been paid, as indicated on the payroll, an amount not less than the sum of the applicable basic hourly wage rate plus the amount of the required fringe benefits as listed in the contract, except as noted in section 4(c) below.

(c) EXCEPTIONS

EXCEPTION (CRAFT)	EXPLANATION

REMARKS:

NAME AND TITLE ELISA VASQUEZ, ADMINSTRATOR	SIGNATURE 
THE WILLFUL FALSIFICATION OF ANY OF THE ABOVE STATEMENTS MAY SUBJECT THE CONTRACTOR OR SUBCONTRACTOR TO CIVIL OR CRIMINAL PROSECUTION. SEE SECTION 1001 OF TITLE 18 AND SECTION 231 OF TITLE 31 OF THE UNITED STATES CODE.	

Date DECEMBER 19, 2014

I, ELISA VASQUEZ ADMINISTRATOR
(Name of Signatory Party) (Title)

do hereby state:

(1) That I pay or supervise the payment of the persons employed by
ROJAS CONSTRUCTION & PAVING LLC on the
(Contractor or Subcontractor)

; that during the payroll period commencing on the
(Building or Work)
20 day of OCTOBER, 2014, and ending the 26 day of OCTOBER, 2014,
all persons employed on said project have been paid the full weekly wages earned, that no rebates have
been or will be made either directly or indirectly to or on behalf of said

ROJAS CONSTRUCTION & PAVING LLC from the full
(Contractor or Subcontractor)

weekly wages earned by any person and that no deductions have been made either directly or indirectly
from the full wages earned by any person, other than permissible deductions as defined in Regulations, Part
3 (29 C.F.R. Subtitle A), issued by the Secretary of Labor under the Copeland Act, as amended (48 Stat. 948,
63 Stat. 108, 72 Stat. 967; 76 Stat. 357; 40 U.S.C. § 3145), and described below:

(2) That any payrolls otherwise under this contract required to be submitted for the above period are
correct and complete; that the wage rates for laborers or mechanics contained therein are not less than the
applicable wage rates contained in any wage determination incorporated into the contract; that the classifications
set forth therein for each laborer or mechanic conform with the work he performed.

(3) That any apprentices employed in the above period are duly registered in a bona fide apprenticeship
program registered with a State apprenticeship agency recognized by the Bureau of Apprenticeship and
Training, United States Department of Labor, or if no such recognized agency exists in a State, are registered
with the Bureau of Apprenticeship and Training, United States Department of Labor.

(4) That:

(a) WHERE FRINGE BENEFITS ARE PAID TO APPROVED PLANS, FUNDS, OR PROGRAMS

-- in addition to the basic hourly wage rates paid to each laborer or mechanic listed in
the above referenced payroll, payments of fringe benefits as listed in the contract
have been or will be made to appropriate programs for the benefit of such employees,
except as noted in section 4(c) below.

(b) WHERE FRINGE BENEFITS ARE PAID IN CASH

-- Each laborer or mechanic listed in the above referenced payroll has been paid,
as indicated on the payroll, an amount not less than the sum of the applicable
basic hourly wage rate plus the amount of the required fringe benefits as listed
in the contract, except as noted in section 4(c) below.

(c) EXCEPTIONS

EXCEPTION (CRAFT)	EXPLANATION

REMARKS:

NAME AND TITLE ELISA VASQUEZ, ADMINSTRATOR	SIGNATURE 
THE WILLFUL FALSIFICATION OF ANY OF THE ABOVE STATEMENTS MAY SUBJECT THE CONTRACTOR OR SUBCONTRACTOR TO CIVIL OR CRIMINAL PROSECUTION. SEE SECTION 1001 OF TITLE 18 AND SECTION 231 OF TITLE 31 OF THE UNITED STATES CODE.	

Date DECEMBER 19, 2014

I, ELISA VASQUEZ ADMINISTRATOR
(Name of Signatory Party) (Title)

do hereby state:

(1) That I pay or supervise the payment of the persons employed by
ROJAS CONSTRUCTION & PAVING LLC on the
(Contractor or Subcontractor)

27 day of OCTOBER, 2014, and ending the 2 day of NOVEMBER, 2014
(Building or Work); that during the payroll period commencing on the
all persons employed on said project have been paid the full weekly wages earned, that no rebates have
been or will be made either directly or indirectly to or on behalf of said

ROJAS CONSTRUCTION & PAVING LLC from the full
(Contractor or Subcontractor)

weekly wages earned by any person and that no deductions have been made either directly or indirectly
from the full wages earned by any person, other than permissible deductions as defined in Regulations, Part
3 (29 C.F.R. Subtitle A), issued by the Secretary of Labor under the Copeland Act, as amended (48 Stat. 948,
63 Stat. 106, 72 Stat. 967; 76 Stat. 357; 40 U.S.C. § 3145), and described below:

(2) That any payrolls otherwise under this contract required to be submitted for the above period are
correct and complete; that the wage rates for laborers or mechanics contained therein are not less than the
applicable wage rates contained in any wage determination incorporated into the contract; that the classifications
set forth therein for each laborer or mechanic conform with the work he performed.

(3) That any apprentices employed in the above period are duly registered in a bona fide apprenticeship
program registered with a State apprenticeship agency recognized by the Bureau of Apprenticeship and
Training, United States Department of Labor, or if no such recognized agency exists in a State, are registered
with the Bureau of Apprenticeship and Training, United States Department of Labor.

(4) That:
(a) WHERE FRINGE BENEFITS ARE PAID TO APPROVED PLANS, FUNDS, OR PROGRAMS

-- in addition to the basic hourly wage rates paid to each laborer or mechanic listed in
the above referenced payroll, payments of fringe benefits as listed in the contract
have been or will be made to appropriate programs for the benefit of such employees,
except as noted in section 4(c) below.

(b) WHERE FRINGE BENEFITS ARE PAID IN CASH

-- Each laborer or mechanic listed in the above referenced payroll has been paid,
as indicated on the payroll, an amount not less than the sum of the applicable
basic hourly wage rate plus the amount of the required fringe benefits as listed
in the contract, except as noted in section 4(c) below.

(c) EXCEPTIONS

EXCEPTION (CRAFT)	EXPLANATION

REMARKS:

NAME AND TITLE ELISA VASQUEZ, ADMINISTRATOR	SIGNATURE 
THE WILLFUL FALSIFICATION OF ANY OF THE ABOVE STATEMENTS MAY SUBJECT THE CONTRACTOR OR SUBCONTRACTOR TO CIVIL OR CRIMINAL PROSECUTION. SEE SECTION 1001 OF TITLE 18 AND SECTION 231 OF TITLE 31 OF THE UNITED STATES CODE.	

Date DECEMBER 19, 2014

I, ELISA VASQUEZ _____ ADMINISTRATOR
(Name of Signatory Party) (Title)

do hereby state:

(1) That I pay or supervise the payment of the persons employed by
ROJAS CONSTRUCTION & PAVING LLC _____ on the
(Contractor or Subcontractor)

_____ that during the payroll period commencing on the
(Building or Work)
10 day of NOVEMBER, 2014, and ending the 16 day of NOVEMBER, 2014,
all persons employed on said project have been paid the full weekly wages earned, that no rebates have
been or will be made either directly or indirectly to or on behalf of said

ROJAS CONSTRUCTION & PAVING LLC _____ from the full
(Contractor or Subcontractor)

weekly wages earned by any person and that no deductions have been made either directly or indirectly
from the full wages earned by any person, other than permissible deductions as defined in Regulations, Part
3 (29 C.F.R. Subtitle A), issued by the Secretary of Labor under the Copeland Act, as amended (48 Stat. 948,
63 Stat. 108, 72 Stat. 967; 76 Stat. 357; 40 U.S.C. § 3145), and described below:

(2) That any payrolls otherwise under this contract required to be submitted for the above period are
correct and complete; that the wage rates for laborers or mechanics contained therein are not less than the
applicable wage rates contained in any wage determination incorporated into the contract; that the classifications
set forth therein for each laborer or mechanic conform with the work he performed.

(3) That any apprentices employed in the above period are duly registered in a bona fide apprenticeship
program registered with a State apprenticeship agency recognized by the Bureau of Apprenticeship and
Training, United States Department of Labor, or if no such recognized agency exists in a State, are registered
with the Bureau of Apprenticeship and Training, United States Department of Labor.

(4) That:

(a) WHERE FRINGE BENEFITS ARE PAID TO APPROVED PLANS, FUNDS, OR PROGRAMS

— in addition to the basic hourly wage rates paid to each laborer or mechanic listed in
the above referenced payroll, payments of fringe benefits as listed in the contract
have been or will be made to appropriate programs for the benefit of such employees,
except as noted in section 4(c) below.

(b) WHERE FRINGE BENEFITS ARE PAID IN CASH

— Each laborer or mechanic listed in the above referenced payroll has been paid,
as indicated on the payroll, an amount not less than the sum of the applicable
basic hourly wage rate plus the amount of the required fringe benefits as listed
in the contract, except as noted in section 4(c) below.

(c) EXCEPTIONS

EXCEPTION (CRAFT)	EXPLANATION

REMARKS:

NAME AND TITLE ELISA VASQUEZ, ADMINSTRATOR	SIGNATURE 
THE WILLFUL FALSIFICATION OF ANY OF THE ABOVE STATEMENTS MAY SUBJECT THE CONTRACTOR OR SUBCONTRACTOR TO CIVIL OR CRIMINAL PROSECUTION. SEE SECTION 1001 OF TITLE 18 AND SECTION 231 OF TITLE 31 OF THE UNITED STATES CODE.	

Date DECEMBER 19, 2014

I, ELISA VASQUEZ ADMINISTRATOR
(Name of Signatory Party) (Title)

do hereby state:

(1) That I pay or supervise the payment of the persons employed by
ROJAS CONSTRUCTION & PAVING LLC on the
(Contractor or Subcontractor)

; that during the payroll period commencing on the
(Building or Work)
17 day of NOVEMBER, 2014, and ending the 23 day of NOVEMBER, 2014,
all persons employed on said project have been paid the full weekly wages earned, that no rebates have
been or will be made either directly or indirectly to or on behalf of said

ROJAS CONSTRUCTION & PAVING LLC from the full
(Contractor or Subcontractor)

weekly wages earned by any person and that no deductions have been made either directly or indirectly
from the full wages earned by any person, other than permissible deductions as defined in Regulations, Part
3 (29 C.F.R. Subtitle A), issued by the Secretary of Labor under the Copeland Act, as amended (48 Stat. 948,
63 Stat. 108, 72 Stat. 967; 76 Stat. 357; 40 U.S.C. § 3145), and described below:

(2) That any payrolls otherwise under this contract required to be submitted for the above period are
correct and complete; that the wage rates for laborers or mechanics contained therein are not less than the
applicable wage rates contained in any wage determination incorporated into the contract; that the classifications
set forth therein for each laborer or mechanic conform with the work he performed.

(3) That any apprentices employed in the above period are duly registered in a bona fide apprenticeship
program registered with a State apprenticeship agency recognized by the Bureau of Apprenticeship and
Training, United States Department of Labor, or if no such recognized agency exists in a State, are registered
with the Bureau of Apprenticeship and Training, United States Department of Labor.

(4) That:
(a) WHERE FRINGE BENEFITS ARE PAID TO APPROVED PLANS, FUNDS, OR PROGRAMS

- in addition to the basic hourly wage rates paid to each laborer or mechanic listed in
the above referenced payroll, payments of fringe benefits as listed in the contract
have been or will be made to appropriate programs for the benefit of such employees,
except as noted in section 4(c) below.

(b) WHERE FRINGE BENEFITS ARE PAID IN CASH

- Each laborer or mechanic listed in the above referenced payroll has been paid,
as indicated on the payroll, an amount not less than the sum of the applicable
basic hourly wage rate plus the amount of the required fringe benefits as listed
in the contract, except as noted in section 4(c) below.

(c) EXCEPTIONS

EXCEPTION (CRAFT)	EXPLANATION

REMARKS:

NAME AND TITLE ELISA VASQUEZ, ADMINSTRATOR	SIGNATURE 
THE WILLFUL FALSIFICATION OF ANY OF THE ABOVE STATEMENTS MAY SUBJECT THE CONTRACTOR OR SUBCONTRACTOR TO CIVIL OR CRIMINAL PROSECUTION. SEE SECTION 1001 OF TITLE 18 AND SECTION 231 OF TITLE 31 OF THE UNITED STATES CODE.	



U.S. Department of Labor
Wage and Hour Division

PAYROLL
(For Contractor's Optional Use; See Instructions at www.dol.gov/whd/forms/wh347instr.htm)

Persons are not required to respond to the collection of information unless it displays a currently valid OMB control number.

NAME OF CONTRACTOR OR SUBCONTRACTOR ADDRESS 240 FRONTAGE RD ALAMO, TX 78516 OMB No.: 1235-0008 Expires: 01/31/2015

PAYROLL NO. 7 FOR WEEK ENDING 11/30/2014 PROJECT AND LOCATION FM495 DRAIN WISCONSIN ROAD CROSSING PROJECT OR CONTRACT NO. HCDD1-13-022-04-29B

(1) NAME AND INDIVIDUAL IDENTIFYING NUMBER (e.g., LAST FOUR DIGITS OF SOCIAL SECURITY NUMBER) OF WORKER	(2) EXEMPTIONS OR	(3) WORK CLASSIFICATION	(4) DAY AND DATE							(5) TOTAL HOURS	(6) RATE OF PAY	(7) GROSS AMOUNT EARNED	(8) DEDUCTIONS				(9) NET WAGES PAID FOR WEEK
			M	T	W	TH	F	S	S				FICA	WITH- HOLDING TAX	MEDI CARE	SS	
ALEJANDRO PEREZ 4414 HODES AVE HARLINGEN, TX SS# XXX-XX-3151	0	COMMON LABORER								29.00	\$15.00	\$290.00	\$28.00	\$4.21	\$17.98	\$50.19	\$239.81
ERNESTO MEDRANO 19042 RD 870 SAN BENITO, TX SS# XXX-XX-3848	2	SUPERVISION								31.00	\$18.00	\$372.00	\$18.00	\$5.39	\$23.06	\$46.45	\$325.55
SERGIO MEDRANO 19042 RD 870 SAN BENITO, TX SS# XXX-XX-2140	3	COMMON LABORER								22.00	\$14.79	\$216.92	\$0.00	\$3.14	\$13.45	\$16.59	\$200.33
JUAN TELLO 25727 LEIGH AVE SAN BENITO, TX SS# XXX-XX-3904	3	EXCAVATOR OPERATOR OVER 50,000LBS								40.00	\$35.43	\$945.00	\$66.00	\$13.71	\$58.59	\$138.30	\$806.70

While completion of Form WH-347 is optional, it is mandatory for covered contractors and subcontractors performing work on Federally financed or assisted construction contracts to respond to the information collection contained in 29 C.F.R. §§ 3.3, 5.5(e). The Copeland Act (40 U.S.C. § 3145) contractors and subcontractors performing work on Federally financed or assisted construction contracts to "furnish weekly a statement with respect to the wages paid each employee during the preceding week." U.S. Department of Labor (DOL) regulations at 29 C.F.R. § 5.5(a)(3)(ii) require contractors to submit weekly a copy of all payrolls to the Federal agency contracting for or financing the construction project, accompanied by a signed "Statement of Compliance" indicating that the payrolls are correct and complete and that each laborer or mechanic has been paid not less than the proper Davis-Bacon prevailing wage rate for the work performed. DOL and federal contracting agencies receiving this information review the information to determine that employees have received legally required wages and fringe benefits.

We estimate that it will take an average of 55 minutes to complete this collection, including time for reviewing instructions, including time for reviewing instructions, gathering and maintaining the data needed, and completing and reviewing the collection of information. If you have any comments regarding these estimates or any other aspect of this collection, including suggestions for reducing this burden, send them to the Administrator, Wage and Hour Division, U.S. Department of Labor, Room S3502, 200 Constitution Avenue, N.W., Washington, D.C. 20210

Public Burden Statement

(over)

Date DECEMBER 9, 2014

I, ELISA VASQUEZ ADMINISTRATOR
(Name of Signatory Party) (Title)

do hereby state:

(1) That I pay or supervise the payment of the persons employed by
ROJAS CONSTRUCTION & PAVING LLC on the
(Contractor or Subcontractor)

24 day of NOVEMBER, 2014, and ending the 30 day of NOVEMBER, 2014
(Building or Work); that during the payroll period commencing on the

all persons employed on said project have been paid the full weekly wages earned, that no rebates have
been or will be made either directly or indirectly to or on behalf of said

ROJAS CONSTRUCTION & PAVING LLC from the full
(Contractor or Subcontractor)

weekly wages earned by any person and that no deductions have been made either directly or indirectly
from the full wages earned by any person, other than permissible deductions as defined in Regulations, Part
3 (29 C.F.R. Subtitle A), issued by the Secretary of Labor under the Copeland Act, as amended (48 Stat. 948,
63 Stat. 108, 72 Stat. 967; 76 Stat. 357; 40 U.S.C. § 3145), and described below:

(2) That any payrolls otherwise under this contract required to be submitted for the above period are
correct and complete; that the wage rates for laborers or mechanics contained therein are not less than the
applicable wage rates contained in any wage determination incorporated into the contract; that the classifications
set forth therein for each laborer or mechanic conform with the work he performed.

(3) That any apprentices employed in the above period are duly registered in a bona fide apprenticeship
program registered with a State apprenticeship agency recognized by the Bureau of Apprenticeship and
Training, United States Department of Labor, or if no such recognized agency exists in a State, are registered
with the Bureau of Apprenticeship and Training, United States Department of Labor.

(4) That:
(a) WHERE FRINGE BENEFITS ARE PAID TO APPROVED PLANS, FUNDS, OR PROGRAMS

- in addition to the basic hourly wage rates paid to each laborer or mechanic listed in
the above referenced payroll, payments of fringe benefits as listed in the contract
have been or will be made to appropriate programs for the benefit of such employees,
except as noted in section 4(c) below.

(b) WHERE FRINGE BENEFITS ARE PAID IN CASH

- Each laborer or mechanic listed in the above referenced payroll has been paid,
as indicated on the payroll, an amount not less than the sum of the applicable
basic hourly wage rate plus the amount of the required fringe benefits as listed
in the contract, except as noted in section 4(c) below.

(c) EXCEPTIONS

EXCEPTION (CRAFT)	EXPLANATION

REMARKS:

NAME AND TITLE ELISA VASQUEZ, ADMINSTRATOR	SIGNATURE 
THE WILLFUL FALSIFICATION OF ANY OF THE ABOVE STATEMENTS MAY SUBJECT THE CONTRACTOR OR SUBCONTRACTOR TO CIVIL OR CRIMINAL PROSECUTION. SEE SECTION 1001 OF TITLE 18 AND SECTION 231 OF TITLE 31 OF THE UNITED STATES CODE.	

Test Report Table

PROJECT: FM495 Drain - Wisconsin Road Crossing - HCDD1-13-022-04-29B

HIDALGO COUNTY

Material	Test	Description	Required	Remarks	Pay Req 1 CS.#	Pay Req 2 CS.#	Pay Req 3 CS.#	Pay Req - FINAL CS.#	Pay Req 5 CS.#
Soils	ASTM D698	Laboratory Compaction Characteristics of Soil Using Standard Effort			HCDD1-13-022-04-29B				
	ASTM D1540	Amount of Material in Soils Finer than No. 200 (75-µm) Sieve							
	ASTM D4318	Liquid Limit, Plastic Limit, and Plasticity Index of Soils							
	ASTM D558	Moisture-Density (Unit Weight) Relations of Soil-Cement Mixtures			HCDD1-13-022-04-29B				
	ASTM D6938	In-Place Density and Water Content of Soil and Soil-Aggregate by Nuclear Methods (Shallow Depth)			HCDD1-13-022-04-29B (2)				
Subgrade	Tex-101-E Part III	Pulverization							
	Tex-115-E	Laboratory Compaction Characteristics & Moisture Density Relationship of Base Materials							
	Tex-114-E	Laboratory Compaction Characteristics & Moisture Density Relationship of Sub-Grade, Embankment Soils, and Backfill Material							
	Tex-101-E	Surveying and Sampling Soils for Highways							
Flex Base	Tex-103-E	Determining Moisture Content in Soil Materials							
	Tex-104-E	Determining Liquid Limit of Soils							
	Tex-105-E	Determining Plastic Limit of Soils							
	Tex-106-E	Calculating the Plasticity Index of Soils							
	Tex-107-E	Determining the Bar Linear Shrinkage of Soils							
	Tex-110-E	Particle Size Analysis of Soils							
	Tex-115-E	Field Method for Determining In-Place Density of Soils and Base Materials							
	Tex-116-E	Bal Mill Method for Determining the Disintegration of Flexible Base Material							
	Tex-117-E	Triaxial Compression for Disturbed Soils and Base Materials							
	EN-1	IAV/ASTM 4639							
	TexDOT 121 E								
	ASTM D 4548								
	ASTM D 1587								
Hot Mix	Tex-207-F	Determining Density of Compacted Bituminous Mixtures							
	Tex-208-F	Test for Stabilometer Value of Bituminous Mixtures							
	Tex-210-F	Determining Asphalt Content of Bituminous Mixtures by Extraction							
	Tex-206-F	Determining Asphalt Content of Bituminous Mixtures by the Nuclear Method							
	Tex-220-F	Combined HMA Cold Batch Sampling and Testing Procedure							
	Tex-209-F	Determining Asphalt Content from Asphalt Paving Mixtures by the Ignition Method							
	Tex-207-E	Determining Density of Compacted Bituminous Mixtures							
	Tex-212-E	Determining Moisture Content of Bituminous Mixtures							
	Tex-213-E	Determining Hydrocarbon - Volatile Content of Bituminous Mixtures							
	In-Place Density	ASTM D-2950/78							
	AASHTO T-188								
Lime	Tex-500-J	Lime Testing Procedure (Moisture Testing if less than 50 Tons from a Pre-Approved Source)							
		Three Edge Bearing Test							
RCP									
Concrete		Compressive Strength Test							

Engineer's Signature:

Rain [Signature], P.E.

Exhibit E-G

LABORATORY TESTING REPORT

Moisture-Density Relationship, Atterberg Limits, and Minus No. 200 Determination



Raba Kistner Consultants Inc.
800 East Hackberry
McAllen, Texas 78501
(956) 682-5332 • FAX(956) 682-5487
www.rkci.com
TBPE Firm F-3257

ATTN.: MR. RAMIRO GUTIERREZ, P.E., PRESIDENT
TO: R. GUTIERREZ ENGINEERING CORPORATION
130 EAST PARK AVENUE
PHARR, TEXAS 78577

PROJECT NO.: AMD14-056-00
SAMPLE DATE: 11/11/2014
ASSIGNMENT NO.: M14-013754
REPORT VERSION: A
TECHNICIAN: ALEJANDRO RAY HERNANDEZ

PROJECT: Hidalgo County Drainage District 1 FM 495 Drain Wisconsin Rd. Crossing, Edinburg, Hidalgo County, Texas

A sample of the following material was obtained by RKCI for laboratory testing : Dark Brown Lean Clay (Backfill Material). This material was obtained from the following location: Stockpiled Material On-Site, Near STA.: 289 + 50.

This material was obtained from The Project Site and is intended for use as Backfill Matrial.

On the basis of the testing conducted and in general accordance with ASTM D 2487: Unified Soil Classification System, the material is classified as CL

Moisture-Density Relationship Test, ASTM D 698 Method A	
Maximum Dry Density, (pcf)	104.7
Optimum Moisture Content, (%)	18.7

The Proctor curve is available upon request. Tested By: JUAN M CARRILLO

Finer Than No. 200 Sieve Determination, ASTM D 1140	
Finer Than No. 200 Sieve, (%)	99.8

Tested By: MANUEL DE SANTIAGO III

Atterberg Limits, ASTM D 4318	
Average Liquid Limit	40
Average Plastic Limit	16
Average Plasticity Index	24

Tested By: MANUEL DE SANTIAGO III

NOTICE: Raba Kistner Consultants, Inc. considers the data and information contained in this report to be proprietary. This information is intended only for the use of the recipient(s) named herein. Test results presented herein relate only to those items tested. This document and any information contained herein shall not be disclosed and shall not be duplicated or used in whole or in part for any purpose other than to validate test results without written approval from Raba Kistner Consultants, Inc.

COPIES TO: Above (1)
R. Gutierrez Engineering Corporation (2)

RABA KISTNER CONSULTANTS, INC.

BY: Carlos Ceballos Jr.
11/18/2014



Updated By: MMR 11/17/2014 8:33:37AM

Austin • Brownsville • Dallas • El Paso • Houston • McAllen • Mexico • New Braunfels • Salt Lake City • San Antonio



LABORATORY TESTING REPORT

Moisture-Density Relationship of Soil-Cement Mixtures



Raba Kistner Consultants Inc.
800 East Hackberry
McAllen, Texas 78501
(956) 682-5332 • FAX(956) 682-5487
www.rkci.com
TBPE Firm F-3257

ATTN.: MR. RAMIRO GUTIERREZ, P.E., PRESIDENT
TO: R. GUTIERREZ ENGINEERING CORPORATION
130 EAST PARK AVENUE
PHARR, TEXAS 78577

PROJECT NO.: AMD14-056-00
SAMPLE DATE: 11/12/2014
ASSIGNMENT NO.: M14-013778
REPORT VERSION: A
TECHNICIAN: ARMANDO RODRIGUEZ JR

PROJECT: Hidalgo County Drainage District 1 FM 495 Drain Wisconsin Rd. Crossing, Edinburg, Hidalgo County, Texas

A sample of the following material was obtained by RKCI for laboratory testing : Light Brown Sand Cement-Treated Backfill Material. This material was obtained from the following location: Stockpiled Material On-Site.

This material was obtained from The Project Site and is intended for use as Cement Treated Backfill Material in the following area: Along Wisconsin Road.

Moisture-Density Relationship Test, ASTM D 558	
Maximum Dry Density, (pcf)	98.0
Optimum Moisture Content, (%)	19.0

The Proctor curve is available upon request.

Tested By: JUAN M CARRILLO

NOTICE: Raba Kistner Consultants, Inc. considers the data and information contained in this report to be proprietary. This information is intended only for the use of the recipient(s) named herein. Test results presented herein relate only to those items tested. This document and any information contained herein shall not be disclosed and shall not be duplicated or used in whole or in part for any purpose other than to validate test results without written approval from Raba Kistner Consultants, Inc.

COPIES TO: Above (1)
R. Gutierrez Engineering Corporation (2)

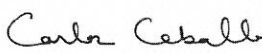
RABA KISTNER CONSULTANTS, INC.

BY: _____
11/20/2014



Updated By: CCJ 11/20/2014 9:47:03AM

Austin • Brownsville • Dallas • El Paso • Houston • McAllen • Mexico • New Braunfels • Salt Lake City • San Antonio



FIELD TEST REPORT

Soil/Base Material Nuclear Density Test



Raba Kistner Consultants Inc.
800 East Hackberry
McAllen, Texas 78501
(956) 682-5332 • FAX(956) 682-5487
www.rkci.com
TBPE Firm F-3257

ATTN.: MR. RAMIRO GUTIERREZ, P.E., PRESIDENT
TO: **R. GUTIERREZ ENGINEERING CORPORATION**
130 EAST PARK AVENUE
PHARR, TEXAS 78577

PROJECT NO.: AMD14-056-00
DATE OF TEST: 11/18/2014
ASSIGNMENT NO.: M14-013835
REPORT VERSION: A
SHEET NUMBER: 1 of 1
TECHNICIAN: ALEJANDRO RAY
HERNANDEZ

**PROJECT: Hidalgo County Drainage District 1 FM 495 Drain
Wisconsin Rd. Crossing, Edinburg, Hidalgo County, Texas**

TEST NO.	TEST LOCATION	SOIL TYPE	LIFT NO. /DEPTH	MOISTURE CONTENT (%)	DRY DENSITY (PCF)	PERCENT PROCTOR (%)	CONFORM
	<u>36" Diameter ADS By-Pass Embankment</u>						
1	Near STA.: 288 + 00, on Centerline of Trench	1	FINAL	18.5	103.4	98.8	Yes
2	Near STA.: 290 + 00, on Centerline of Trench	1	FINAL	16.7	103.7	99.0	Yes

CURVE ID.	SOIL TYPE	OPTIMUM MOISTURE (%)	MAX. DRY DENSITY (PCF)	REQUIRED MOISTURE (%)	REQUIRED DENSITY (%)	LAB TEST PROCEDURE
1	Dark Brown Lean Clay (Backfill Material) (PI:24)	18.7	104.7	16.7-20.7	95	ASTM D 698 Method A

REFERENCE: Backfill/Utility Line

FIELD TEST PROCEDURE: ASTM D 6938

GAUGE NUMBER: 5

REMARKS: Lift and station information is provided by contractor.

PERSON NOTIFIED: Mr. Juan Uribe w/R. Gutierrez Engineering Corp.

CONTRACTOR: Rojas Construction

* - Indicates noncompliance with specifications.

NOTICE: Raba Kistner Consultants, Inc. considers the data and information contained in this report to be proprietary. This information is intended only for the use of the recipient(s) named herein. Test results presented herein relate only to those items tested. This document and any information contained herein shall not be disclosed or used in whole or in part for any purpose other than to validate test results without written approval from Raba Kistner Consultants, Inc.

COPIES TO: Above (1)

R. Gutierrez Engineering Corporation (2)

RABA KISTNER CONSULTANTS, INC.

BY: *Carlos Ceballos Jr.*
11/20/2014

FIELD TEST REPORT

Soil/Base Material Nuclear Density Test

ATTN.: MR. RAMIRO GUTIERREZ, P.E., PRESIDENT
 TO: R. GUTIERREZ ENGINEERING CORPORATION
 130 EAST PARK AVENUE
 PHARR, TEXAS 78577



Raba Kistner Consultants Inc.
 800 East Hackberry
 McAllen, Texas 78501
 (956) 682-5332 • FAX(956) 682-5487
 www.rkci.com
 TBPE Firm F-3257

PROJECT NO.: AMD14-056-00
 DATE OF TEST: 12/01/2014
 ASSIGNMENT NO.: M14-013993
 REPORT VERSION: A
 SHEET NUMBER: 1 of 1
 TECHNICIAN: VICTOR SALINAS IIII

PROJECT: Hidalgo County Drainage District 1 FM 495 Drain
 Wisconsin Rd. Crossing, Edinburg, Hidalgo County, Texas

TEST NO.	TEST LOCATION	SOIL TYPE	LIFT NO. /DEPTH	MOISTURE CONTENT (%)	DRY DENSITY (PCF)	PERCENT PROCTOR (%)	CONFORM
	Along East Wisconsin Road, 8'x8' Box Culvert						
3	Near STA.: 289 + 00, on Centerline	1	FINAL	18.9	105.0	100.3	Yes
4	Near STA.: 289 + 50, on Centerline	2	1ST	19.1	98.5	100.5	Yes

CURVE ID.	SOIL TYPE	OPTIMUM MOISTURE (%)	MAX. DRY DENSITY (PCF)	REQUIRED MOISTURE (%)	REQUIRED DENSITY (%)	LAB TEST PROCEDURE
1	Dark Brown Lean Clay (Backfill Material) (PI:24)	18.7	104.7	16.7-20.7	95	ASTM D 698 Method A
2	Light Brown Sand Cement-Treated Backfill Material	19.0	98.0	17-21	95	ASTM D 558

REFERENCE: Pavemen Section

FIELD TEST PROCEDURE: ASTM D 6938

GAUGE NUMBER: 4

REMARKS: Lift and station information is provided by contractor.

PERSON NOTIFIED: Mr. Juan Uribe w/R. Gutierrez Engineering Corp.

CONTRACTOR: Rojas Construction

* - Indicates noncompliance with specifications.

NOTICE: Raba Kistner Consultants, Inc. considers the data and information contained in this report to be proprietary. This information is intended only for the use of the recipient(s) named herein. Test results presented herein relate only to those items tested. This document and any information contained herein shall not be disclosed and shall not be duplicated or used in whole or in part for any purpose other than to validate test results without written approval from Raba Kistner Consultants, Inc.

COPIES TO: Above (1)
 R. Gutierrez Engineering Corporation (2)

RABA KISTNER CONSULTANTS, INC.

BY: *Carlos Ceballos*
 12/05/2014

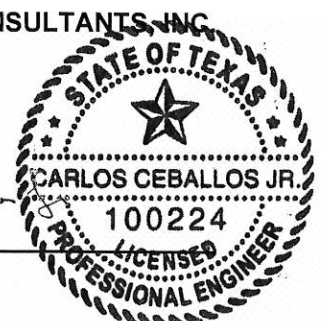

Updated By: MMR 12/5/2014 4:57:57PM

Austin • Brownsville • Dallas • El Paso • Houston • McAllen • Mexico • New Braunfels • Salt Lake City • San Antonio



HIDALGO COUNTY DRAINAGE DISTRICT NUMBER ONE

902 NORTH DOOLITTLE

EDINBURG, TEXAS 78542

(956) 292-7080

FAX (956) 292-7089



GODFREY GARZA, JR.
MANAGER

January 05, 2015

Lora Briones
Financial Officer

Re: Invoice

1.) Foremost Paving, Inc. / Inv. # App. For PMT #1 / \$161,405.00 / 11-22-2014

I have reviewed the invoice referenced above, and have no issues for payment based on my onsite inspection and back up information, they are billing the Drainage District. If you should have any questions, please feel free to contact me.

Thank you,

J. Noe Saldivar. P.E.
Hydraulic Engineer

Date: 1/5/15 Time: 4:15 P.M

Cc: Godfrey Garza Jr., CFM

LBroni 1/5/2015

AI #48166
1/20/15



**COVERSHEET
APPROVED-BOND INVOICES**

Submitted to Noe

DATE: 12/29/2014

Prepared By: Joey Garza

Vendor	Unit #	Invoice #	Invoice Date	Invoice Amount	Received By	Received Date	COMMENTS
FOREMOST PAVING, INC.	PCT.2 MISSON INLET	APP. FOR PMT #1	11/22/14	\$161,405.00	R. ARCE	12/22/14	PO# 625593 ATTACHED
ROJAS HEAVY EQUIPMENT, LLC DBA ROJAS CONSTRUCTION PAVING 201,236.50	PCT 2 FM 495-WISCONSIN RD CROSSING DRAINAGE IMPROVEMENT	APP. FOR PMT #1	11/30/14	\$150,255.80	R. ARCE	12/22/14	PO# 625108 ATTACHED
FOREMOST PAVING, INC.	PCT.2 MISSON INLET	APP. FOR RETAINAGE	11/22/14	\$8,495.00	R. ARCE	12/22/14	PO# 625593 ATTACHED
TEDSI INFRA. GROUP.	PCT NO. 1 2012 BOND REFERENDUM	20142174	12/22/14	\$3,847.01	R. ARCE	12/24/14	PO# 623664 ATTACHED WITH BACKUP DVD 1 OF1
TEDSI INFRA GROUP.	PCT NO. 1 2012 BOND REFERENDUM	20142175	12/22/14	\$645.55	R. ARCE	12/24/14	PO# 623578 ATTACHED
TEDSI INFRA. GROUP.	PCT NO. 1 2012 BOND REFERENDUM	20142176	12/22/14	\$12,051.00	R. ARCE	12/24/14	PO# 623574 ATTACHED WITH BACKUP DVD INVOICE
TEDSI INFRA. GROUP.	PCT NO. 1 2012 BOND REFERENDUM	20142177	12/22/14	\$262.83	R. ARCE	12/24/14	PO# 623665 ATTACHED
TEDSI INFRA. GROUP.	PCT NO. 1 2012 BOND REFERENDUM	20142178	12/22/14	\$159,944.34	R. ARCE	12/24/14	PO# 623666 ATTACHED
TEDSI INFRA GROUP.	PCT NO. 1 2012 BOND REFERENDUM	20142179	11/22/14	\$7,438.56	R. ARCE	12/24/14	PO# 623576 ATTACHED
TEDSI INFRA GROUP.	PCT 1 2012 BOND REFERENDUM PROJECT	20142180	12/22/14	\$22,604.50	R. ARCE	12/24/14	PO# 625166 ATTACHED WITH BACKUP DVD

*AGB
1/5/15*

*AGB
1/5/15*

*AGB
1/5/15*

HIDALGO COUNTY DRAINAGE DISTRICT NUMBER ONE

902 NORTH OODLITTLE

EDINBURG, TEXAS 78542

(956) 292-7080

FAX (956) 292-7089



GODFREY GARZA, JR.
MANAGER

January 05, 2015

Lora Briones
Financial Officer

Re: Invoice

1.) Foremost Paving, Inc. / Inv. # Application for Retainage / \$8,495.00 / 11-22-2014

I have reviewed the invoice referenced above, and have no issues for payment based on my onsite inspection and back up information, they are billing the Drainage District. If you should have any questions, please feel free to contact me.

Thank you,

J. Noe Saldivar, P.E.
Hydraulic Engineer

Date: 1/5/15 Time: 4:15 PM

Cc: Godfrey Garza Jr., CFM

LB

1-5-2015

AI # 48166
1/20/15



**COVERSHEET
APPROVED-BOND INVOICES**

Submitted to Noe

DATE: 12/29/2014

Prepared By: Joey Garza

Vendor	Unit #	Invoice #	Invoice Date	Invoice Amount	Received By	Received Date	COMMENTS
FOREMOST PAVING, INC.	PCT.2 MISSON INLET	APP. FOR PMT #1	11/22/14	\$161,405.00	R. ARCE	12/22/14	PO# 625593 ATTACHED
ROJAS HEAVY EQUIPMENT, LLC DBA ROJAS CONSTRUCTION PAVING 201,236.50	PCT 2 FM 495-WISCONSIN RD CROSSING DRAINAGE IMPROVEMENT	APP. FOR PMT #1	11/30/14	\$150,255.80	R. ARCE	12/22/14	PO# 625108 ATTACHED
FOREMOST PAVING, INC.	PCT.2 MISSON INLET	APP. FOR RETAINAGE	11/22/14	\$8,495.00	R. ARCE	12/22/14	PO# 625593 ATTACHED
TEDSI INFRA. GROUP.	PCT NO. 1 2012 BOND REFERENDUM	20142174	12/22/14	\$3,847.01	R. ARCE	12/24/14	PO# 623664 ATTACHED WITH BACKUP DVD 1 OF 1
TEDSI INFRA GROUP.	PCT NO. 1 2012 BOND REFERENDUM	20142175	12/22/14	\$645.55	R. ARCE	12/24/14	PO# 623578 ATTACHED
TEDSI INFRA. GROUP.	PCT NO. 1 2012 BOND REFERENDUM	20142176	12/22/14	\$12,051.00	R. ARCE	12/24/14	PO# 623574 ATTACHED WITH BACKUP DVD INVOICE
TEDSI INFRA. GROUP.	PCT NO. 1 2012 BOND REFERENDUM	20142177	12/22/14	\$262.83	R. ARCE	12/24/14	PO# 623665 ATTACHED
TEDSI INFRA. GROUP.	PCT NO. 1 2012 BOND REFERENDUM	20142178	12/22/14	\$159,944.34	R. ARCE	12/24/14	PO# 623666 ATTACHED
TEDSI INFRA GROUP.	PCT NO. 1 2012 BOND REFERENDUM	20142179	11/22/14	\$7,438.56	R. ARCE	12/24/14	PO# 623576 ATTACHED
TEDSI INFRA GROUP.	PCT 1 2012 BOND REFERENDUM PROJECT	20142180	12/22/14	\$22,604.50	R. ARCE	12/24/14	PO# 625166 ATTACHED WITH BACKUP DVD

*JAG
1/5/15*

*JAG
1/5/15*

*JAG
1/5/15*

HIDALGO COUNTY DRAINAGE DISTRICT NUMBER ONE

902 NORTH DOOLITTLE

EDINBURG, TEXAS 78542

(956) 292-7080

FAX (956) 292-7089



GODFREY GARZA, JR.
MANAGER

January 05, 2015

Lora Briones
Financial Officer

150,255.80

Re: Invoice

1.) Rojas Construction & Paving / Invoice # Application for PMT #1/ 11-30-2014

I have reviewed the invoice referenced above, and have no issues for payment based on my onsite inspection and back up information, they are billing the Drainage District. If you should have any questions, please feel free to contact me.

Thank you,

J. Noe Saldivar, P.E.
Hydraulic Engineer

Date: 1/5/15 Time: 4:15 P.M.

Cc: Godfrey Garza Jr., CFM

for
Law
1/5/2015

AI# 48166
1/20/15



**COVERSHEET
APPROVED-BOND INVOICES**

Submitted to Noe

DATE: 12/29/2014

Prepared By: Joey Garza

Vendor	Unit #	Invoice #	Invoice Date	Invoice Amount	Received By	Received Date	COMMENTS
FOREMOST PAVING, INC.	PCT.2 MISSON INLET	APP. FOR PMT #1	11/22/14	\$161,405.00	R. ARCE	12/22/14	PO# 625593 ATTACHED
ROJAS HEAVY EQUIPMENT, LLC DBA ROJAS CONSTRUCTION PAVING 201,236.50	PCT 2 FM 495-WISCONSIN RD CROSSING DRAINAGE IMPROVEMENT	APP. FOR PMT #1	11/30/14	\$150,255.80	R. ARCE	12/22/14	PO# 625108 ATTACHED
FOREMOST PAVING, INC.	PCT.2 MISSON INLET	APP. FOR RETAINAGE	11/22/14	\$8,495.00	R. ARCE	12/22/14	PO# 625593 ATTACHED
TEDSI INFRA. GROUP.	PCT NO. 1 2012 BOND REFERENDUM	20142174	12/22/14	\$3,847.01	R. ARCE	12/24/14	PO# 623664 ATTACHED WITH BACKUP DVD 1 OF 1
TEDSI INFRA GROUP.	PCT NO. 1 2012 BOND REFERENDUM	20142175	12/22/14	\$645.55	R. ARCE	12/24/14	PO# 623578 ATTACHED
TEDSI INFRA. GROUP.	PCT NO. 1 2012 BOND REFERENDUM	20142176	12/22/14	\$12,051.00	R. ARCE	12/24/14	PO# 623574 ATTACHED WITH BACKUP DVD INVOICE
TEDSI INFRA. GROUP.	PCT NO. 1 2012 BOND REFERENDUM	20142177	12/22/14	\$262.83	R. ARCE	12/24/14	PO# 623665 ATTACHED
TEDSI INFRA. GROUP.	PCT NO. 1 2012 BOND REFERENDUM	20142178	12/22/14	\$159,944.34	R. ARCE	12/24/14	PO# 623666 ATTACHED
TEDSI INFRA GROUP.	PCT NO. 1 2012 BOND REFERENDUM	20142179	11/22/14	\$7,438.56	R. ARCE	12/24/14	PO# 623576 ATTACHED
TEDSI INFRA GROUP.	PCT 1 2012 BOND REFERENDUM PROJECT	20142180	12/22/14	\$22,604.50	R. ARCE	12/24/14	PO# 625166 ATTACHED WITH BACKUP DVD

JAG 1/5/15
JAG 1/5/15
JAG 1/5/15

AI -48159

14.

DRAINAGE DISTRICT

Meeting Date: 01/20/2015

Submitted By: Sylvia Sanchez, DRAINAGE
DISTRICT

Department: DRAINAGE DISTRICT

Information

CAPTION

Discussion and approval to acquire all right of way in fee simple along Pharr/McAllen South Drain and PSJA South Drain for needed maintenance operation.

BACKGROUND

Fiscal Impact

Attachments

No file(s) attached.

Form Review

Inbox	Reviewed By	Date
Budget & Management	Veronica Ortiz	01/16/2015 10:32 AM
Final Approval	Monica Badillo	01/16/2015 06:31 PM
Form Started By: Sylvia Sanchez		Started On: 01/16/2015 10:27 AM
Final Approval Date: 01/16/2015		

AI -48180

15.

DRAINAGE DISTRICT

Meeting Date: 01/20/2015

Submitted By: Claudette Guerrero,
DRAINAGE DISTRICT

Department: DRAINAGE DISTRICT

Information

CAPTION

Request approval to issue manual payment once review and audit procedures are complete on the following item:

Request for Payment no. 1 in the amount of \$90,000.00 from Texas Cordia Construction related to Construction Contract No. HCDD1-14-008-07-08 Pct.2 Alamo Expressway Drain. PO#625452.

BACKGROUND

Fiscal Impact

Attachments

DD1 PE LTR TXCORDIA PMT#1-ALAMO EXPRESSWA

TxCordia Pmt#1-Alamo Expressway

Form Review

Inbox	Reviewed By	Date
Budget & Management	Veronica Ortiz	01/16/2015 04:23 PM
Final Approval	Monica Badillo	01/16/2015 06:31 PM
Form Started By: Claudette Guerrero		Started On: 01/16/2015 03:30 PM
Final Approval Date: 01/16/2015		

HIDALGO COUNTY DRAINAGE DISTRICT NUMBER ONE

902 NORTH DOOLITTLE

EDINBURG, TEXAS 78542

(956) 292-7080

FAX (956) 292-7089



GODFREY GARZA, JR., C.F.M.
DISTRICT MANAGER

January 16, 2015

Lora Briones
Financial Officer

Re: Invoice

1.) Texas Cordia Construction, LLC (Pct.2 Alamo Expressway Drain)

Inv. # Application #1 / 12-16-14 / \$90,000.00

The above referenced invoice has already been reviewed and certified by Dos Logistics, Inc. The invoice is not for final payment, therefore it does not require my approval. If you should have any questions, please feel free to contact me.

Thank you,

J. Noe Saldivar, P.E.
Hydraulic Engineer

Date: 1/16/15 Time: 11:45 AM

Cc: Godfrey Garza Jr., CFM

1/16/15
11:43 AM.

AS#48180
1/20/15

HIDALGO COUNTY DRAINAGE DISTRICT NUMBER ONE

902 NORTH DOOLITTLE

EDINBURG, TEXAS 78542

(956) 292-7080

FAX (956) 292-7089



GODFREY GARZA, JR.
MANAGER

INVOICE PROCESSING CHECKLIST

Date Received: 01/16/15

Engineer/Firm Name: DL, Inc.

Project Name/Number: Alamo Expressway Drainage

Invoice No: Pay Application # 7

Logged in and Scanned: 4:12 PM By: R. Orell Forwarded to: Joey Garza

Engineer	Name	Date	Comment
Scope of work reviewed			

Accounting	Name	Date	Comment
Encumbrance			
Purchase Order Attached			
Audit			
Final Approval for Agenda			

Placed on Agenda	Name	Date	Comment
Placed on Agenda			

Additional Comments: _____

Letter of Transmittal

To:
Mr. Jaime Salazar
Hidalgo Co. Drainage District No. 1
902 N Doolittle Rd
Edinburg, TX 78540

JOB NO.
ATTN: Mr. Jaime Salazar
RE: Alamo Expressway Drainage

WE ARE SENDING YOU

- | | |
|---------------------------------------|------------|
| SOQ | Check |
| Plans | Proposal |
| Contract | Submittals |
| Invoices | Samples |
| <input type="checkbox"/> Change Order | Originals |

Routing Method:	
US Mail	Certified
Lone Star Overnight	Fed Ex
<input checked="" type="checkbox"/> Hand Delivered	Fax
E-mail	Pick Up

Originals	Date	Copies	
1	1/9/15		Pay Application No. 1

Sylvia S. received these invoice and did not take proper process.

RECEIVED
HIDALGO COUNTY
DRAINAGE DISTRICT #1

JAN 16 2015
4:10 AM
Rosa Ace

THESE ARE TRANSMITTED as checked below:

- | | |
|--------------|------------------------|
| For Approval | Approved as submitted |
| For your use | Approved as noted |
| As requested | Return for corrections |

Returned _____ corrected prints

Remarks:

SIGNED *[Signature]*
Oscar Cancino, P.E.
Principal

RECEIVED BY: _____

DATE: _____

RECEIVED ON: _____

RECEIVED
HIDALGO COUNTY
DRAINAGE DISTRICT #1

JAN 09 2015
1:30 AM / PM
BY: *[Signature]*

APPLICATION AND CERTIFICATE FOR PAYMENT

TO OWNER:
 Hidalgo County Drainage District No. 1
 902 N. Doolittle Rd
 Edinburg TX 78542



PROJECT: PCT. 2 Alamo Expressway Drain
 HCDD1-14-008-07-08

ENGINEER: Dos Logistics, Inc.
 1002 E. Expressway 83
 Weslaco, TX 78596

APPLICATION #: 1
APPLICATION DATE: 12/16/2014
PERIOD TO: 11/26/2014
PROJECT NO: 14-008-07-08
P.O. No.: 625452
CONTRACT DATE: 7/8/2014
CONTRACT DAYS: 120
CONTRACT FIRST WORK DAY: 8/27/2014

Distribution to:

<input checked="" type="checkbox"/>	Owner
<input type="checkbox"/>	Const. Mgr
<input type="checkbox"/>	Architect
<input type="checkbox"/>	Contractor
<input type="checkbox"/>	Engineer

FROM CONTRACTOR:
 Texas Cordia Construction, LLC
 3149-A Center Point Dr
 Edinburg TX 78539

CONTRACT FOR: PCT. 2 Alamo Expressway Drain

CONTRACTOR'S APPLICATION FOR PAYMENT

Application is made for payment, as shown below, in connection with the Contract.
 Continuation Sheet is attached.

1. ORIGINAL CONTRACT SUM-----	\$	920,573.00
2. Net change by Change Orders-----	\$	
3. CONTRACT SUM TO DATE (Line 1 +/- 2)	\$	920,573.00
4. TOTAL COMPLETED & STORED TO DATE-\$		
A. MATERIALS ON HAND		100,000.00
(Column G on Continuation Sheet)		
5. RETAINAGE:		
a. 10.0% of Completed Work	\$	
(Column O on Continuation Sheet)		
b. 10.0% of Stored Material	\$	10,000.00
(Column O on Continuation Sheet)		
Total Retainage (Line 5a + 5b or		
Total in Column O of Continuation Sheet-----	\$	10,000.00
6. TOTAL EARNED LESS RETAINAGE-----	\$	90,000.00
(Line 4 less Line 5 Total)		
7. LESS PREVIOUS CERTIFICATES FOR PAYMENT		
(Line 6 from prior Certificate)-----	\$	
8. CURRENT PAYMENT DUE-----	\$	90,000.00
9. BALANCE TO FINISH, INCLUDING RETAINAGE		
(Line 3 less Line 6)	\$	830,573.00

The undersigned Contractor certifies that to the best of the Contractor's knowledge, information and belief the Work covered by this Application for Payment has been completed in accordance with the Contract Documents, that all amounts have been paid by the Contractor for Work for which previous Certificates for Payment were issued and payments received from the Owner, and that current payment shown therein is now due.

CONTRACTOR:

By: [Signature] Date: 12/16/14

State of: Texas
 County of: Hidalgo
 Subscribed and sworn to before me this 16th day of Dec., 2014

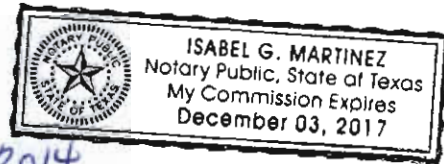

Notary Public: [Signature]
 My Commission expires: 12/3/17

CERTIFICATE FOR PAYMENT

In accordance with Contract Documents, based on on-site observations and the data comprising application, the Architect certifies to the Owner that to the best of the Architect's knowledge, information and belief the Work has progressed as indicated, the quality of the Work is in accordance with the Contract Documents, and the Contractor is entitled to payment of the AMOUNT CERTIFIED.

AMOUNT CERTIFIED ----- \$ 890,000.00

(Attach explanation if amount certified differs from the amount applied for. Initial all figures on this application and on the Continuation Sheet that are changed to conform to the amount certified.)

ENGINEER: Dos Logistics, Inc.

By: [Signature] Date: 1-9-15

This Certificate is not negotiable. The AMOUNT CERTIFIED is payable only to the Contractor named herein. Issuance, payment and acceptance of payment are without prejudice to any rights of the Owner of Contractor under this Contract.

CHANGE ORDER SUMMARY	ADDITIONS	DEDUCTIONS
Total changes approved in previous months by Owner		
Total approved this Month		
TOTALS		
NET CHANGES by Change Order		

CONTINUATION SHEET

ATTACHMENT TO PAY APPLICATION

PROJECT: PCT. 2 Alamo Expressway Drain HCDD1-14-008-07-08

APPLICATION NUMBER: 1

APPLICATION DATE: 12/16/2014

PERIOD TO: 11/26/2014

PROJECT NO: 14-008-07-08

Item No.	Description of Work	UNIT PRICE	CONTRACT		SCHEDULED VALUE	Previous Application		Completed This Period		Material on Hand		Completed To Date		RET	Balance To Finish (F-L)	RET
			QTY	UNIT		QTY	AMOUNT	QTY	AMOUNT	QTY	AMOUNT	QTY	AMOUNT			
BASE BID																
1	EMBANKMENT (NATIVE MATERIAL)	\$12.00	2145	CY	\$ 25,740.00		\$ -		\$ -				\$ -	10%	\$ 25,740.00	\$ -
2	EMBANKMENT (LEVEE GRADE FILL)	\$18.00	910	CY	\$ 16,380.00		\$ -		\$ -				\$ -	10%	\$ 16,380.00	\$ -
3	HYDROMULCH SEEDING (PERM)(WATERING INCLUDED)	\$1.00	4000	SY	\$ 4,000.00		\$ -		\$ -				\$ -	10%	\$ 4,000.00	\$ -
4	CALICHE 6" (NEW)(COMPACTED IN PLACE)	\$90.00	79	CY	\$ 7,110.00		\$ -		\$ -				\$ -	10%	\$ 7,110.00	\$ -
5	CEMENT STABILIZED BACKFILL (2 SACKS/CY)	\$150.00	430	CY	\$ 64,500.00		\$ -		\$ -				\$ -	10%	\$ 64,500.00	\$ -
6	TRENCH EXCAVATION PROTECTION REINFORCED CONCRETE WALL (PIPE SUPPORT)	\$1,100.00	7	CY	\$ 7,700.00		\$ -		\$ -				\$ -	10%	\$ 7,700.00	\$ -
8	CONCRETE RETAINING WALL	\$600.00	26	CY	\$ 15,600.00		\$ -		\$ -				\$ -	10%	\$ 15,600.00	\$ -
9	CONCRETE RIPRAP (6IN)	\$300.00	79	CY	\$ 23,700.00		\$ -		\$ -				\$ -	10%	\$ 23,700.00	\$ -
10	RIPRAP (COMMON STONE)(DRY)(6IN)	\$100.00	395	CY	\$ 39,500.00		\$ -		\$ -				\$ -	10%	\$ 39,500.00	\$ -
11	5'X5' DUAL CONCRETE BOX (CAST IN PLACE)	\$1,005.00	137	LF	\$137,685.00		\$ -		\$ -				\$ -	10%	\$137,685.00	\$ -
12	CONCRETE WINGWALLS	\$5,600.00	2	EA	\$ 11,200.00		\$ -		\$ -				\$ -	10%	\$ 11,200.00	\$ -
13	CONCRETE HEADWALL (VARIES FROM 5' TO 11' HEIGHT)	\$1,000.00	24	LF	\$ 24,000.00		\$ -		\$ -				\$ -	10%	\$ 24,000.00	\$ -
14	BARRICADES, SIGNS AND TRAFFIC HANDLING	\$4,000.00	3	MO	\$ 12,000.00		\$ -		\$ -				\$ -	10%	\$ 12,000.00	\$ -
15	CHANNEL EXCAVATION	\$9.00	5270	CY	\$ 47,430.00		\$ -		\$ -				\$ -	10%	\$ 47,430.00	\$ -
16	CONCRETE COLLAR (CAST IN PLACE) CONSTRUCTION CONCRETE GATEWELL STR.	\$3,300.00	2	EA	\$ 6,600.00		\$ -		\$ -				\$ -	10%	\$ 6,600.00	\$ -
17	W/SLUICE GATE (2), 5" REINFORCED CONCRETE PLATFORM, GRATE LATCH, LADDER & APPARATUS (CAST IN PLACE)	\$111,000.00	1	EA	\$111,000.00		\$ -		\$ -				\$ -	10%	\$111,000.00	\$ -
18	18" STEEL PIPE SCH 40 PAINTED (OIL BASE)(W/12" MANIFOLD, CHECK VALVES & FITTINGS)	\$400.00	60	LF	\$ 24,000.00		\$ -		\$ -				\$ -	10%	\$ 24,000.00	\$ -
19	12" STEEL PIPE SCH 40 PAINTED (OIL BASE)(W/FITTINGS) SUCTION W/BLINDS & QUICK CONNECTORS	\$300.00	65	LF	\$ 19,500.00		\$ -		\$ -				\$ -	10%	\$ 19,500.00	\$ -
20	12' WIDE SWING ACCES GATES (COMPLETE IN PLACE)(PAINTED YELLOW W/OIL BASE PAINT)	\$3,000.00	2	EA	\$ 6,000.00		\$ -		\$ -				\$ -	10%	\$ 6,000.00	\$ -
21	CONSTRUCTION EXISTS (TY2)(INSTALL)(REMOVE)	\$30.00	78	SY	\$ 2,340.00		\$ -		\$ -				\$ -	10%	\$ 2,340.00	\$ -
22	TEMP SEDIMENT CONTROL FENCE	\$4.00	1218	LF	\$ 4,872.00		\$ -		\$ -				\$ -	10%	\$ 4,872.00	\$ -
23	12" DIESEL PUMP W/(2)12"X20" FLEXIBLE HOSE W/QUICK CONNECTOR	\$111,000.00	2	EA	\$222,000.00		\$ -		\$ -	2.00	\$ 100,000.00	2	\$ 100,000.00	10%	\$122,000.00	\$ 10,000.00
24	6'0" X 5'6" CONCRETE SUNCTION BOX (W/GRATES)	\$18,000.00	1	EA	\$ 18,000.00		\$ -		\$ -				\$ -	10%	\$ 18,000.00	\$ -
25	STRUCTURE EXCAVATION	\$12.00	2223	CY	\$ 26,676.00		\$ -		\$ -				\$ -	10%	\$ 26,676.00	\$ -
26	CONTINGENCY PLAN (PRELIM. SOILS MAT'L TESTS)	\$13,000.00	1	LS	\$ 13,000.00		\$ -		\$ -				\$ -	10%	\$ 13,000.00	\$ -
27	CONTINGENCY PLAN (CONST. MAT'L TESTS)	\$13,000.00	1	LS	\$ 13,000.00		\$ -		\$ -				\$ -	10%	\$ 13,000.00	\$ -
SUBTOTAL BASE BID					\$920,573.00		\$ -		\$ -		\$ 100,000.00		\$ 100,000.00		\$820,573.00	\$ 10,000.00
					\$ -		\$ -		\$ -		\$ -		\$ -		\$ -	\$ -
SUBTOTALS PAGE 2					\$920,573.00		\$ -		\$ -		\$ 100,000.00		\$ 100,000.00		\$820,573.00	\$ 10,000.00

January 15, 2015

Mr. Jaime Salazar, Buyer
Hidalgo County Drainage District No. 1
902 N. Doolittle Rd
Edinburg, TX. 78542

Re: Gorman-Rupp Pump MOH Pay App#1
Project: PCT. 2 Alamo Expressway Drain
HCDD1-14-008-07-08

Mr. Salazar

The contractor (Texas Cordia Construction) purchased centrifugal pumps are currently staged at the Hidalgo County Drainage District. The pay application reflects 80% of the cost for MOH being requested and approved. The remaining balance remains for field coordination for the pumps to include the quick connections, hoses and pipe fittings that are required. Revised plans will be provided to the contractor for final installation on the proposed structure.

If you should have any questions or comments please feel free to contact us at 956.968.8800.

Respectfully Submitted,



Oscar Cancino, P.E.
Principal
Dos Logistics, Inc.

Drawing Gorman-Rupp Trailer

January 8, 2015

Mr. Jaime Salazar, Buyer
Hidalgo County Drainage District No. 1
902 N. Doolittle Rd
Edinburg, TX. 78542

Re: Pay Application and Certificate No. 1
Project: PCT. 2 Alamo Expressway Drain
HCDD1-14-008-07-08
Contractor: Texas Cordia Construction, LLC

Mr. Salazar
Attached for payment is Pay Application No. 1 for the aforementioned project.
The application has been reviewed and approved by Dos Logistics Inc. for further
processing as follows:

Original Contract...\$ 920,573.00
Pay Application Amount...\$ 90,000.00

For the work period ending on December 16, 2014.
If you should have any questions or comments please feel free to contact us at
956.968.8800.

Respectfully Submitted,



Oscar Cancino, P.E.
Principal
Dos Logistics, Inc.

Attach: Application and Certificate
Continuation Sheet(s)

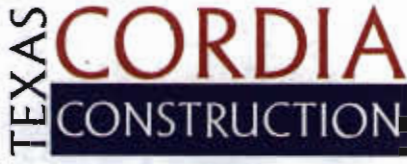

3149-A Center Pointe Drive
Edinburg, TX 78539
O: 956-627-6181
F: 956-386-0289

December 16, 2014

Dos Logistic, Inc.
Attn: Oscar Cancino, P.E.
1002 E. Expressway 83
Weslaco, Texas 78596

RE: Precinct No. 2 – Alamo Expressway Drain
HCDD1-14-008-07-08

Dear Mr. Cancino:

The following is a list of suppliers used in the above mentioned project as per the County's request:

- Balch Machine Co., Inc.

If you have any questions, please contact me at (956) 627-6181.

Thank you,

A handwritten signature in blue ink, appearing to read "Yara M. Corbitt".

Yara M. Corbitt, P.E.
Texas Cordia Construction

BALCH MACHINE CO., INC.

7728 Padre Island Hwy
BROWNSVILLE, TEXAS 78521

INVOICE

40806

DATE

INVOICE NO.

11/17/2014

40806

(956) 831-2644 Fax (956) 831-2274
www.balchmachine.com

RECEIVED NOV 19 2014

BILL TO:

Texas Cordia Construction
3149-A Center Pointe Dr
Edinburg, Tx 78539

SHIP TO:

Texas Cordia Construction LLC
3149-A Center Pointe Drive
Edinburg, TX 78539

P.O. NUMBER	TERMS	REP	SHIP	VIA	F.O.B.	PROJECT
AL2402	Net 30	CB	11/18/2014	Company ...	8-22-14	972058 2 centrifugal ..

QUANTITY	ITEM CODE	DESCRIPTION	PRICE EACH	AMOUNT
		Progress Billing: Material on Hand		
		2 EA Gorman Rupp Pump MOD PA 10A60-4045H Skid Mounted, Self-Priming Diesel Driven with Self contained Diesel Tank		
1	MISCELLA..		125,000.00	125,000.00
		-Sales Tax	8.25%	10,312.50
			TOTAL	125,000. ⁰⁰ 135,312.50